

A96 Corridor Development Strategy Project
Infrastructure Options Report

1 Electricity Network in the A96 Corridor

1.1 Inverness 33kV network

A geographic diagram of this network is given in Appendix A. Inverness 132/33kV GSP supplies Hilton, Raigmore and Culloden primary substations, which supply customers to the east of Inverness.

Seven other primary substations are supplied from Inverness grid supply point (GSP). These substations supply customers in Inverness and to the south of Inverness. A schematic diagram of the 33kV network supplied from Inverness GSP is shown in Figure 1 below.

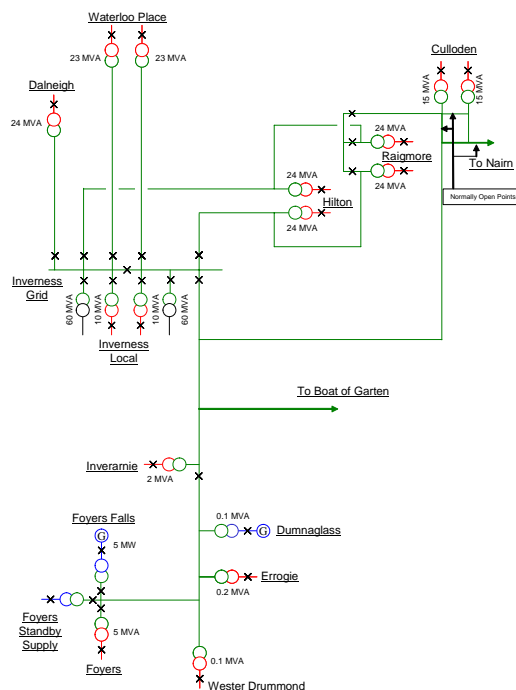

Figure 1: Schematic diagram of the 33kV network supplied from the Inverness GSP

The Inverness 132/33kV Grid Supply substation has two grid transformers, which are fully loaded. It is planned to install third transformer by 2008/09. Taking the whole system in to consideration and to ensure compliance with security of supply obligations, on completion of works it will be possible to supply additional 35 MVA from Inverness 132/33kV Grid Supply substation.

The Inverness-Hilton/Raigmore/Culloden 33kV circuit supplies approximately 15'000 customers. Three 33kV circuits supply three 33/11kV primary substations. The Inverness-Hilton and Hilton-Raigmore circuits are underground cables; and the Inverness-Culloden and Raigmore-Culloden circuits are overhead lines. Hilton and Raigmore are large substations.

2 Demand Growth in the A96 Corridor

Historical demand patterns have been used to determine future load growth for the six substations in the A96 corridor. However, developer forecast information is used if it is higher than the historical demand forecast. Demand forecast for each substation is shown in Table 1.

Substations in the A96 Corridor between Inverness and Nairn	Actual	Forecast		
	Demand 2005/06 (MVA)	Demand 2010/11 (MVA)	Demand 2015/16 (MVA)	Demand 2020/21 (MVA)
Dalcross	7.8	10.1	12	18.9
Arderseir	1.5	2.2	3.8	4.2
McDermotts	0.1	0.1	0.1	0.1
Hilton	11.8	15.1	19.3	24.6
Raigmore	18	21.9	26.6	32.4
Culloden	12.2	18.1	19.9	24.7

Table 1: Demand Forecast for Substations in the A96 Corridor between Inverness and Nairn

Historical and developer demand forecast charts for each primary substation are shown Appendix C. It is likely that development along the A96 corridor could result in about 53 MVA of additional demand on the Inverness and Nairn systems by 2020/21.

3 Network Reinforcement Planning Options

This section discusses three planning options to reinforce the network in the A96 corridor between Inverness and Nairn over the next 15 years.

3.1 Planning Option One: Reinforce the existing 33kV network

The 33kV network reinforcement will include reinforce the Raigmore-Culloden and Inverness-Culloden overhead lines; renew switchgear at Raigmore substation; New Inverness-Raigmore underground circuit; one new primary transformer at Raigmore; Renew primary transformers at Culloden; Reinforce a Nairn-Dalcross/Arderseir/McDermotts and overhead line; Renew switchgear at Culloden substation; and renew switchgear at Hilton substation. The net present value (NPV) for this option will be in the range of £3.6 to £4.1M.

3.2 Planning Option Two: Establish a new GSP next to the Beauly-Keith 132kV overhead line

The 33kV network reinforcement for this option will include New GSP-Culloden underground circuits; new switchgear at Raigmore; new primary transformer at Raigmore; Renew existing transformers at Culloden; Reinforce a Nairn-Dalcross/Arderseir/McDermotts overhead line; new switchgear at Culloden; and new switchgear at Hilton; The NPV for the 33kV reinforcement works will be in the range of £4.5M to £5M. The cost of installing a new 132/33kV grid substation will be in the range £3.2M to £3.7M.

3.3 Planning Option Three: Establish a new GSP remote from the Beauly-Keith 132kV overhead line

The 33kV network reinforcement for this option is similar to planning option two. The NPV for this option will be in the range of £3.6M to £4M. The cost to install a new 132/33kV grid substation will be in the range £8.8M to £9.2M.

3.4 Other Considerations

The above planning options do not include a cost of the 11kV network reinforcement work. At this stage, it is estimated that this work will cost £2M.

4 Summary

The total highest indicative cost (Option 3) to accommodate up to 53MVA in the A96 corridor over the next 15 years is £13.2M. The 11kV network reinforcement cost is estimated to be £2M.

After the two new 33kV cables are laid between Inverness Grid and Hilton in 2007/08 the total network capacity on the six primary substations, in the A96 corridor development zone will be about 30MVA.

Appendix A: Geographic diagram of the 33kV network and primary substations supplied from Inverness Grid

Please see attached PowerPoint file

Appendix B: Geographic diagram of the 33kV network and primary substations supplied from Nairn Grid (N.B. Culloden is normally supplied from Inverness Grid)

Please see attached PowerPoint file

Appendix C: Historical and developer demand forecasts for each substation in the A96 Corridor

