

ALNESS ACADEMY SITE ANALYSIS

This page shows views of the school site from the surrounding streets/approaches and views from the school site.



VIEW OF EXISTING BUILDING



VIEW ACROSS PITCH TOWARDS SITE BOUNDARY



VIEW TOWARDS EXISTING BUILDING



VIEW FROM SPORTS PAVILION CAR PARK



VIEW TOWARDS REAR OF ACADEMY BUILDING



VIEW FROM PEDESTRIAN BRIDGE



VIEW TOWARDS MAIN ENTRANCE



VIEW TOWARDS PROPOSED SCHOOL SITE



VIEW ACROSS PLAYING FIELD S



VIEW ALONG EXISTING ACCESS ROAD

ALNESS ACADEMY
SITE ANALYSIS

This page highlights movement and key features around the site.

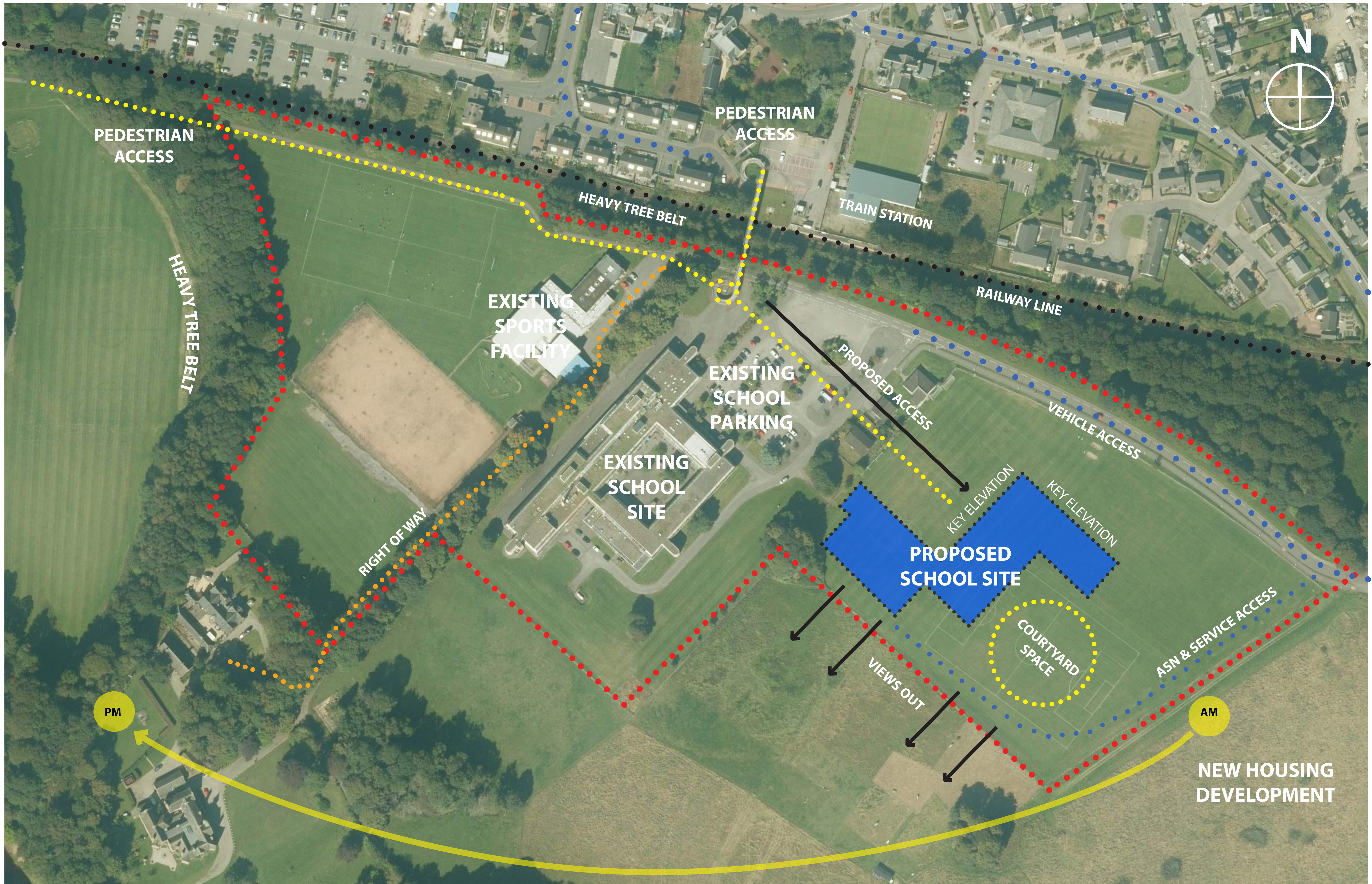

THE PROPOSAL

This page shows the area proposed site plan and highlights its key features.



THE CONCEPT A series of conceptual diagrams helped inform the design of the building.

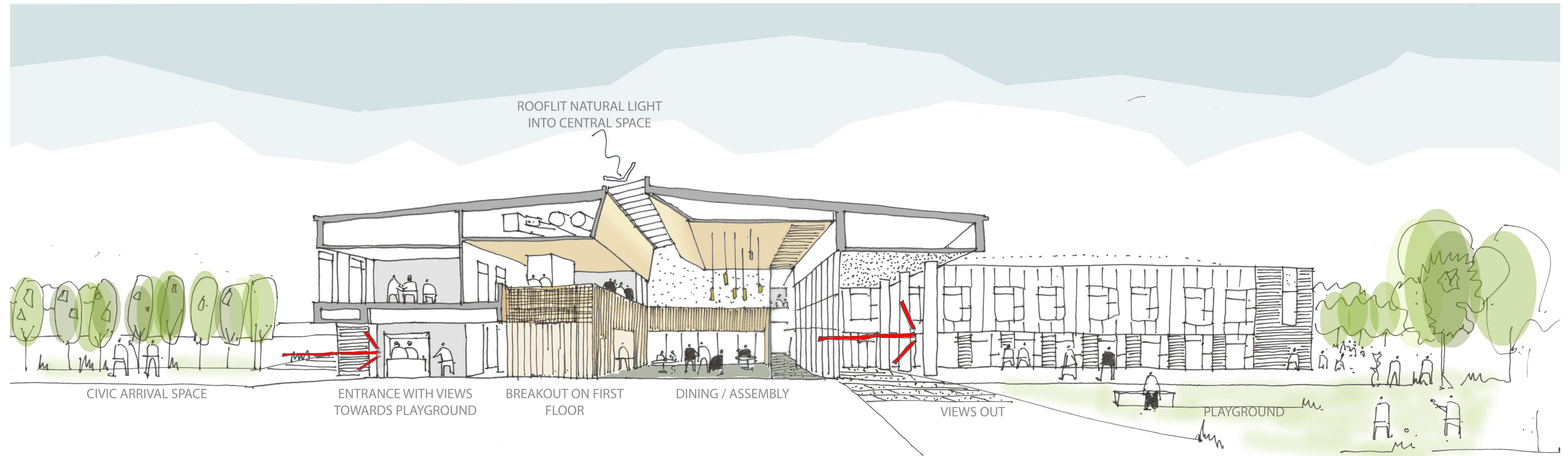

CONCEPT SECTION - CENTRAL COMMUNAL AREAS WITH BREAK OUT SPACES AND WRAP AROUND TEACHING FACILITIES

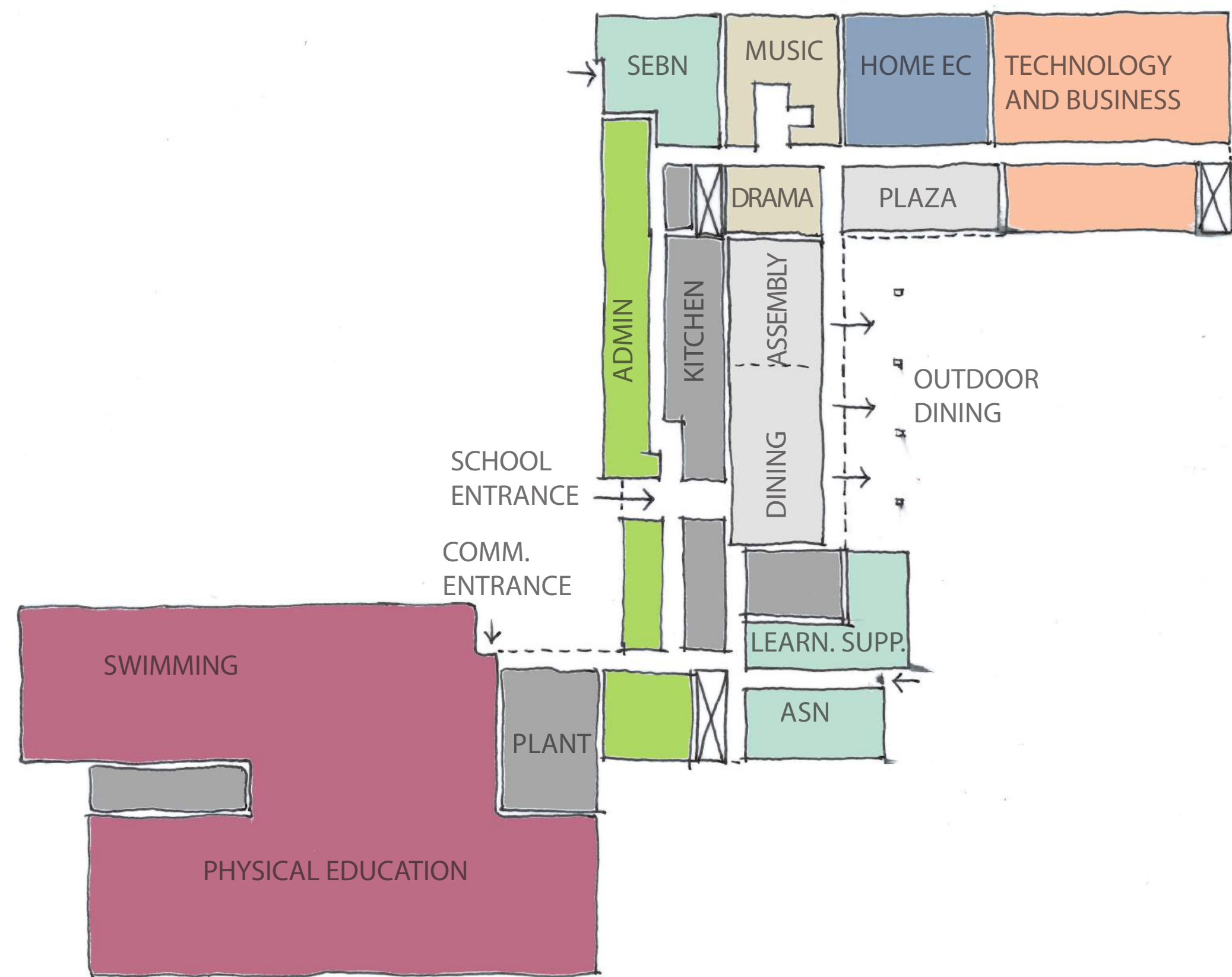

BUILDING ORGANISATION PLAN - GROUND FLOOR

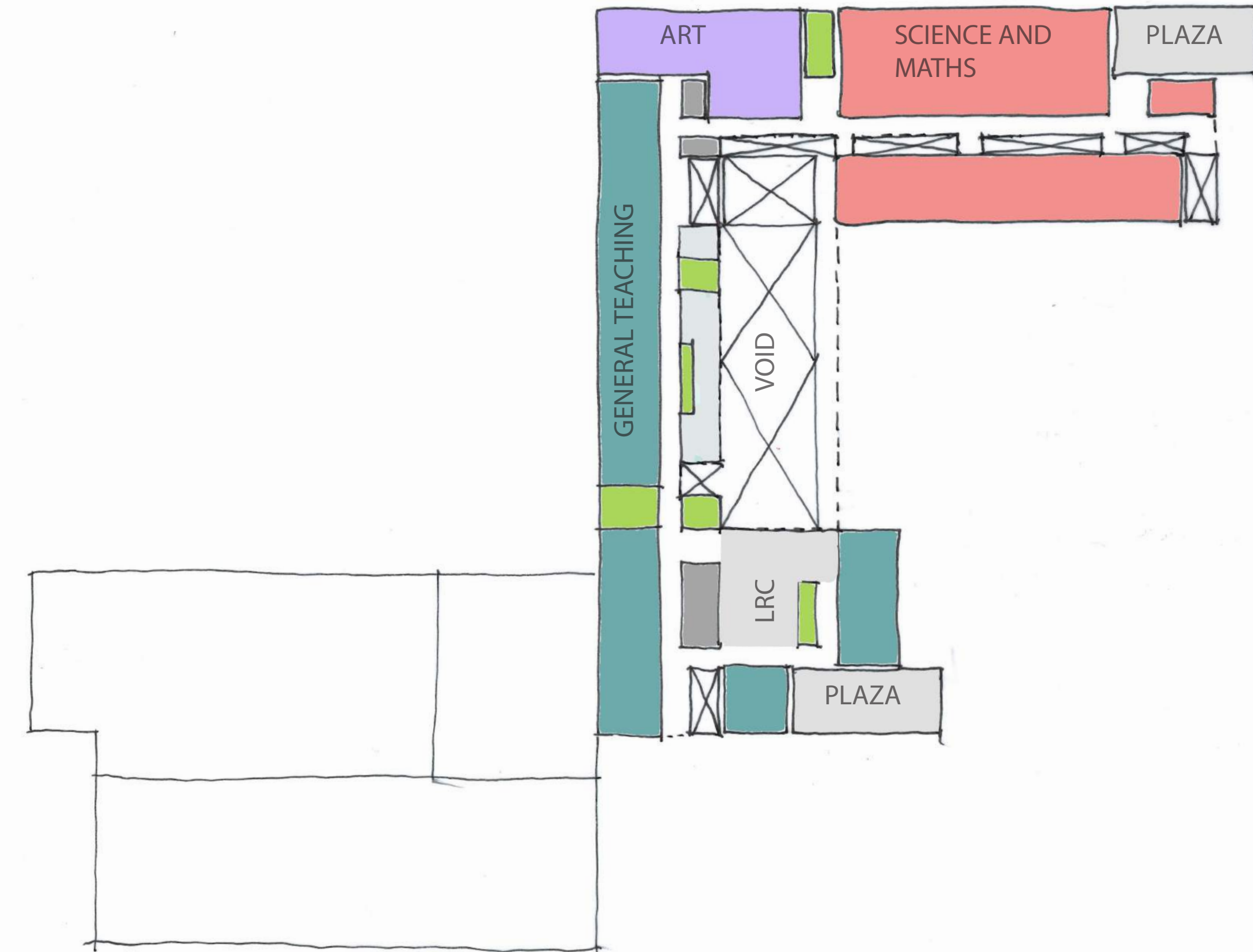

BUILDING ORGANISATION PLAN - FIRST FLOOR



GROUND FLOOR



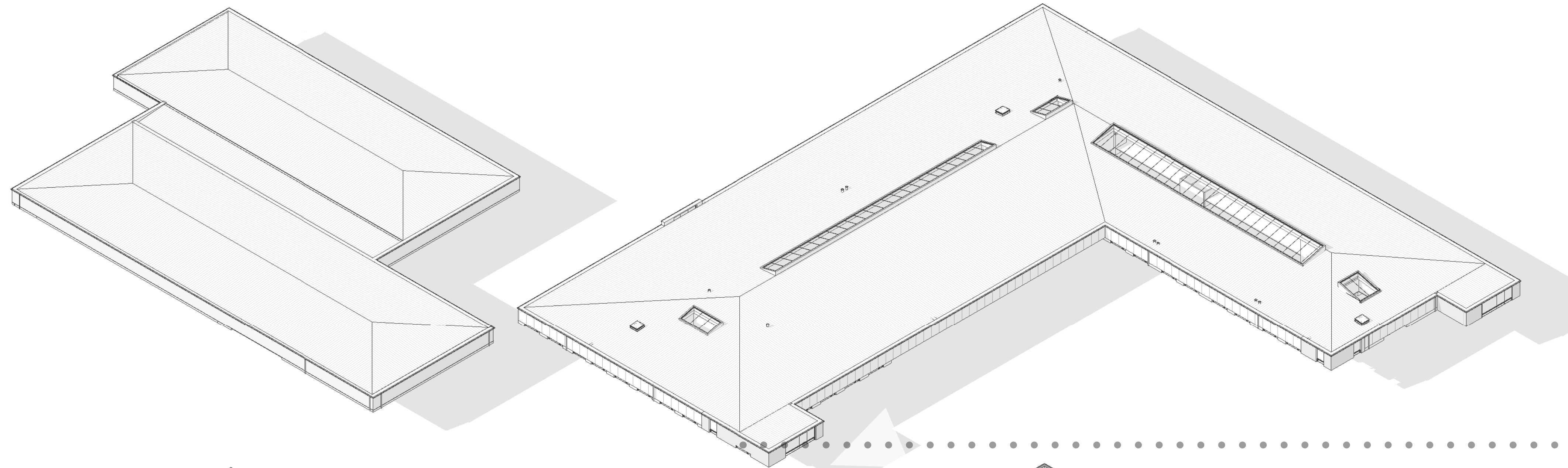

ROOF



FIRST FLOOR



GROUND FLOOR

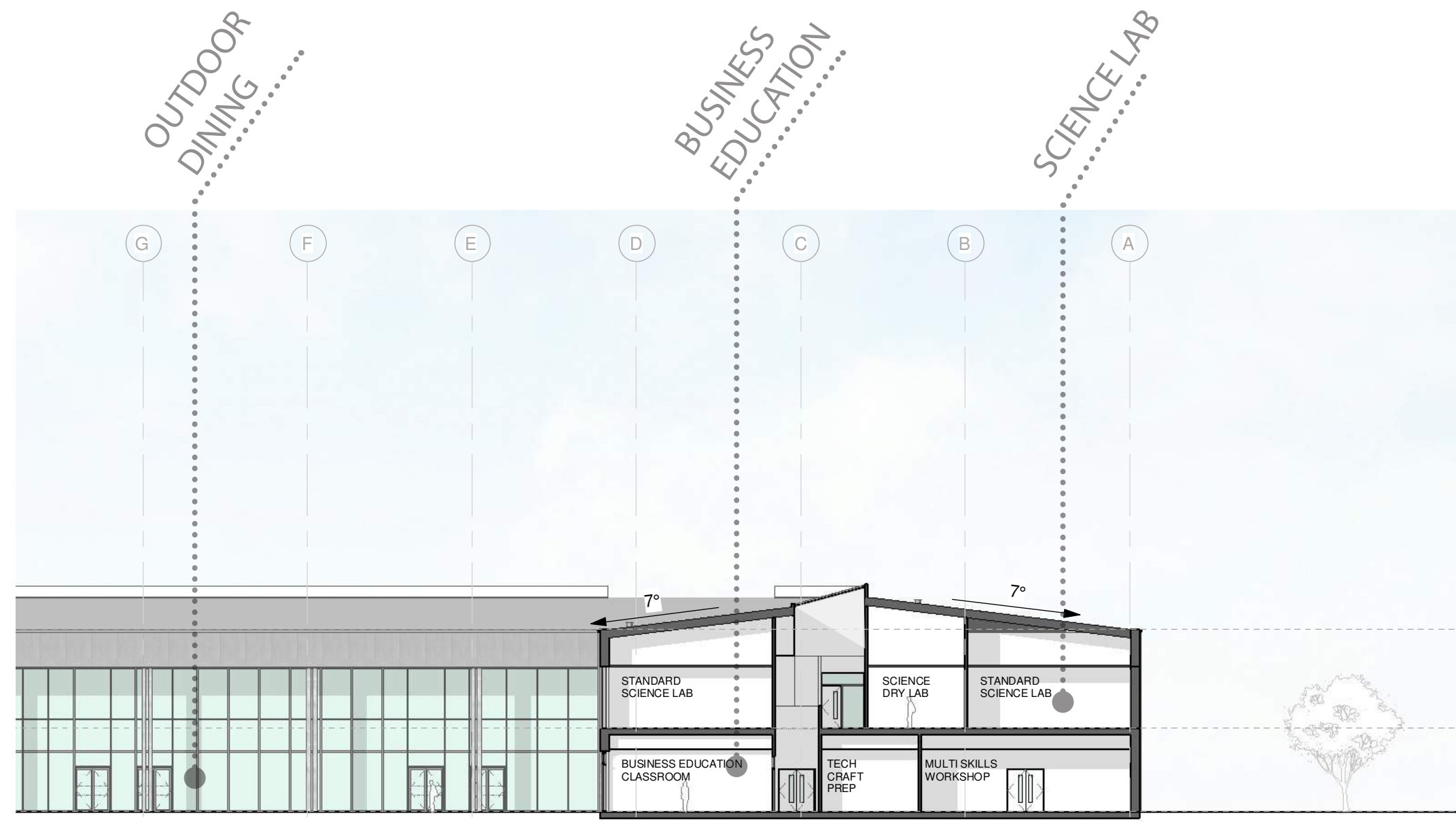

SECTION A-A

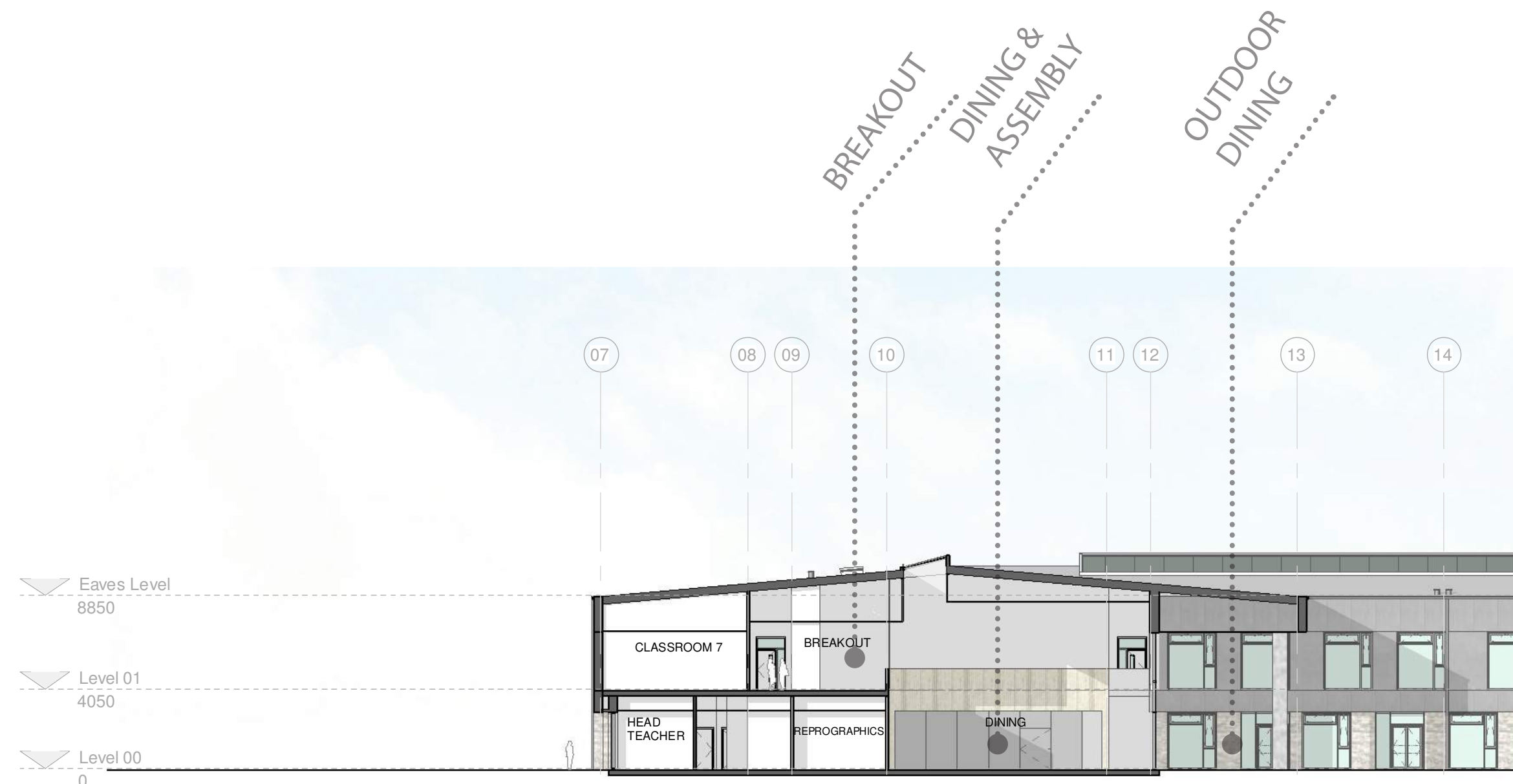

SECTION B-B

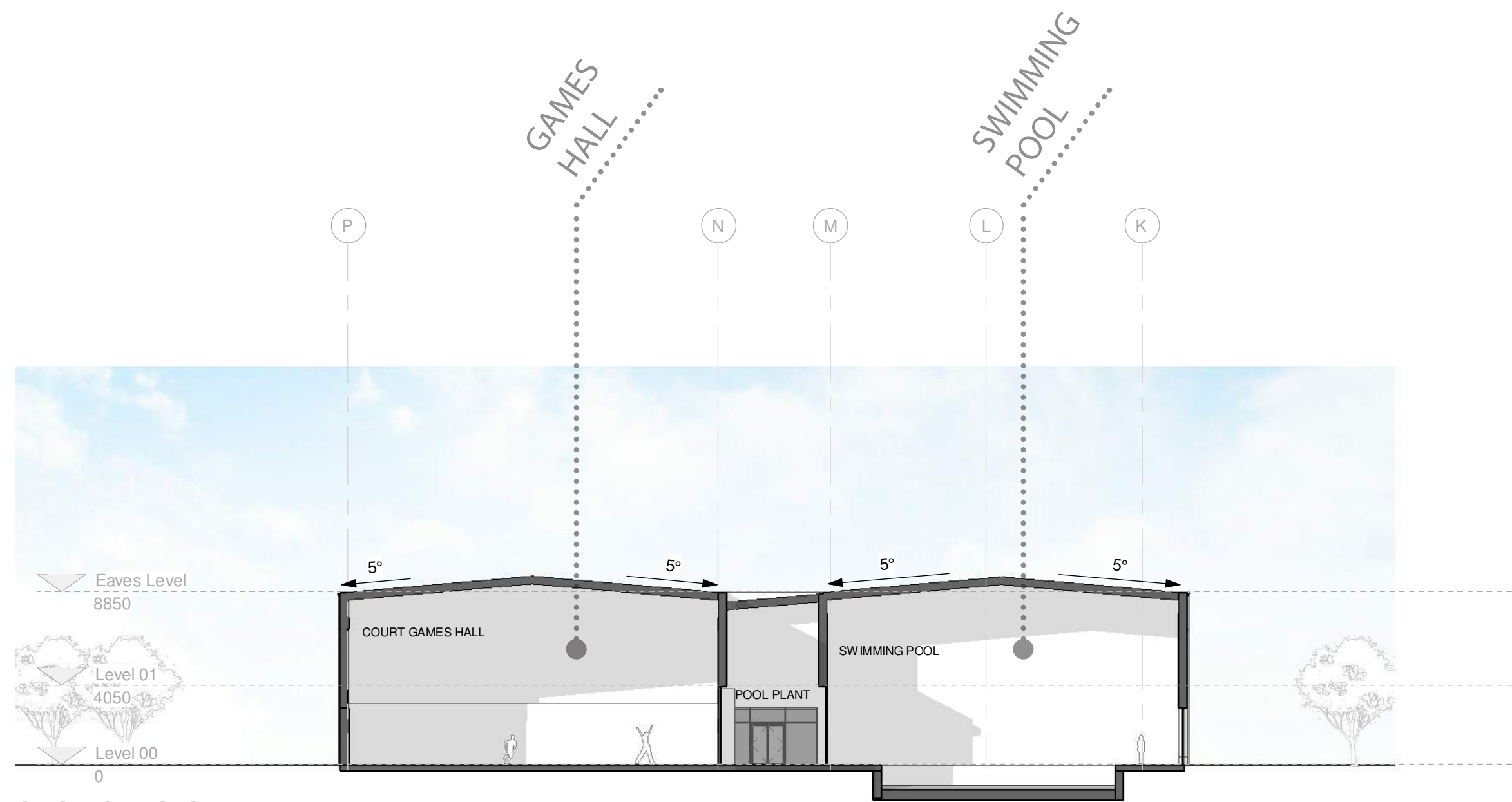
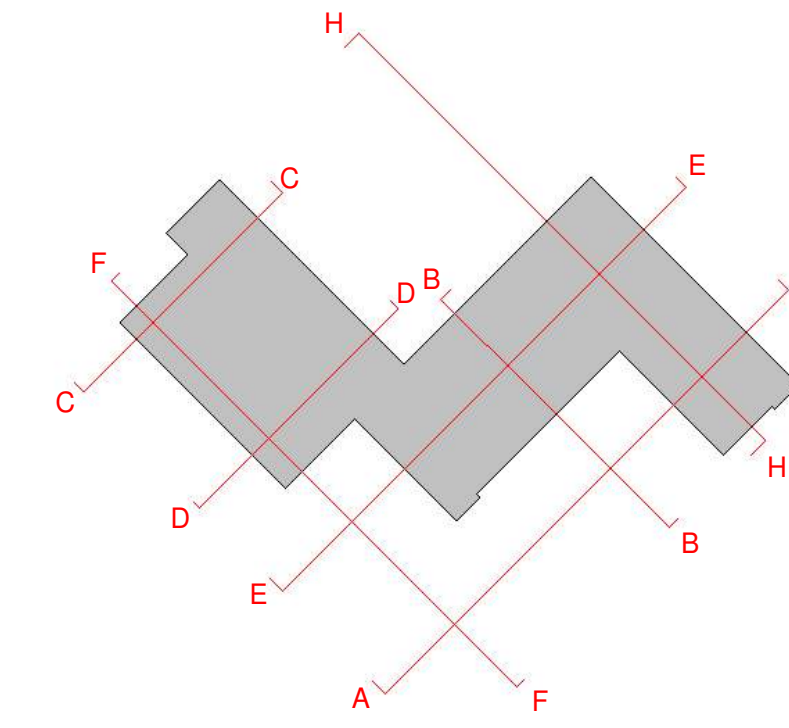

SECTION C-C

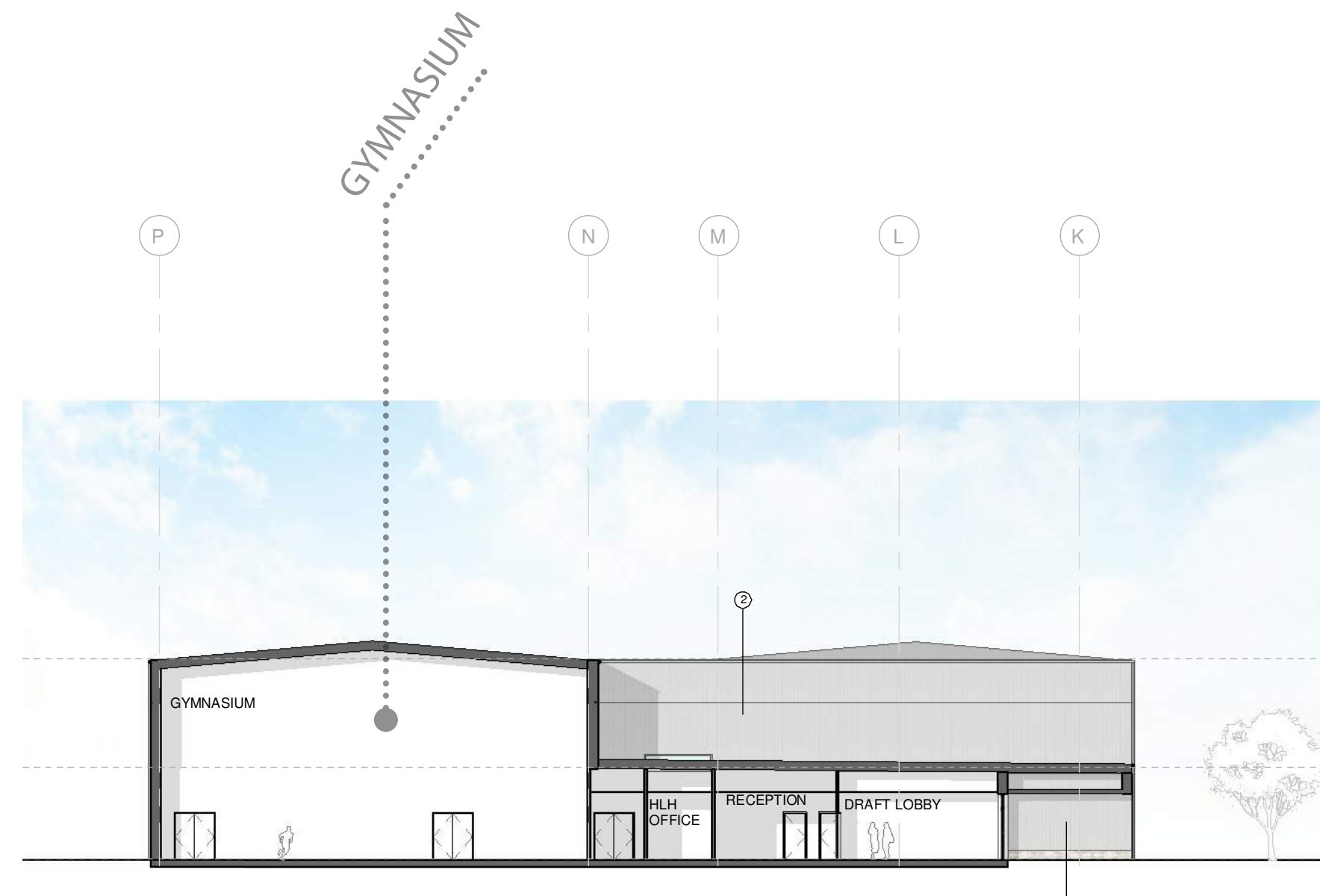

SECTION D-D



SECTION E-E



NORTH WEST ELEVATION STUDY OF TEACHING WING CLASSROOMS



NORTH WEST ELEVATION STUDY OF MAIN ENTRANCE



ELEVATION STUDY OF SPORTS BLOCK

CONCEPT ELEVATION SKETCHES

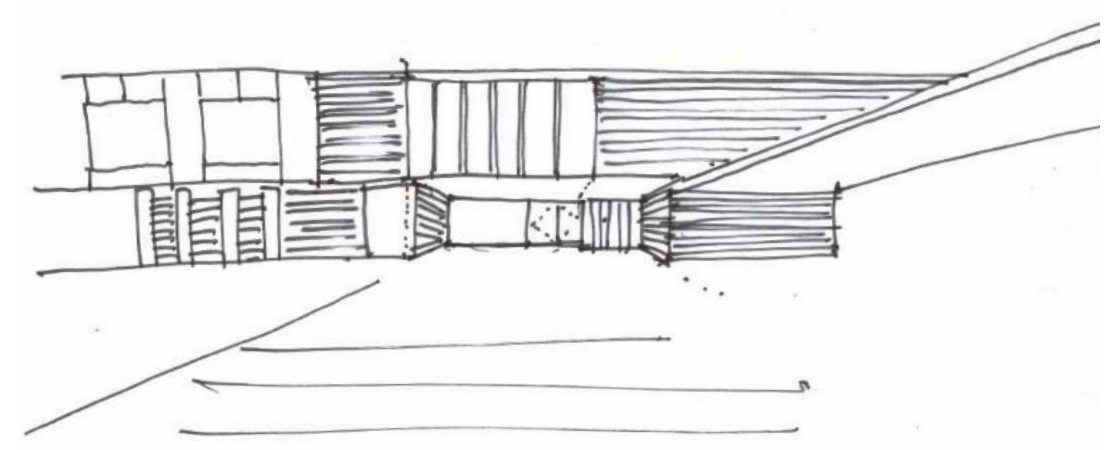
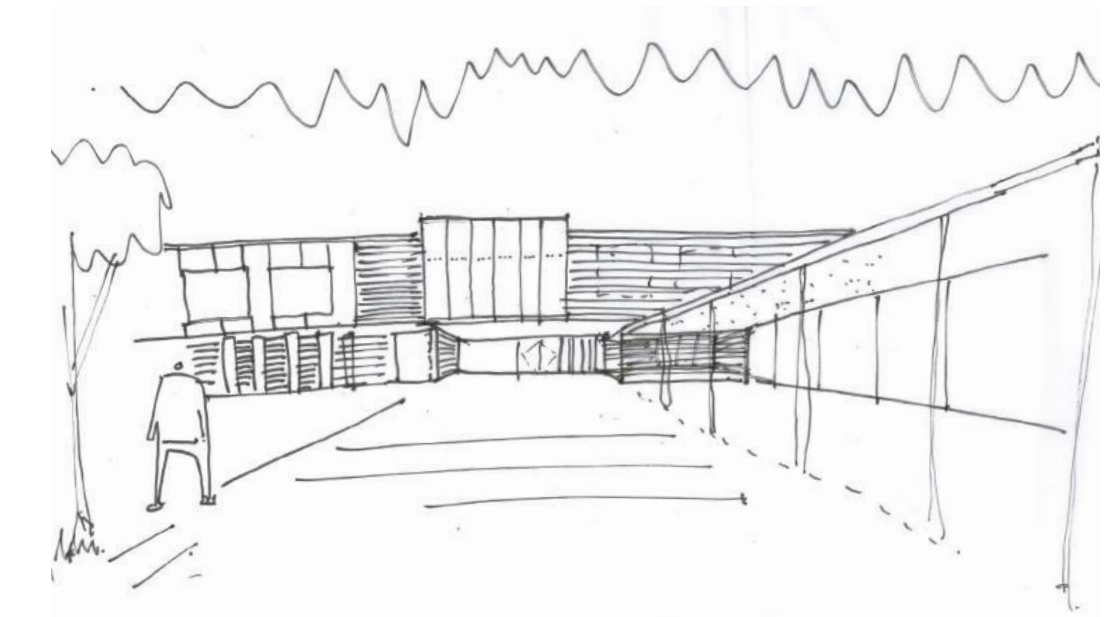

SOUTH EAST ELEVATION STUDY OF TEACHING WING / LEARNING PLAZA

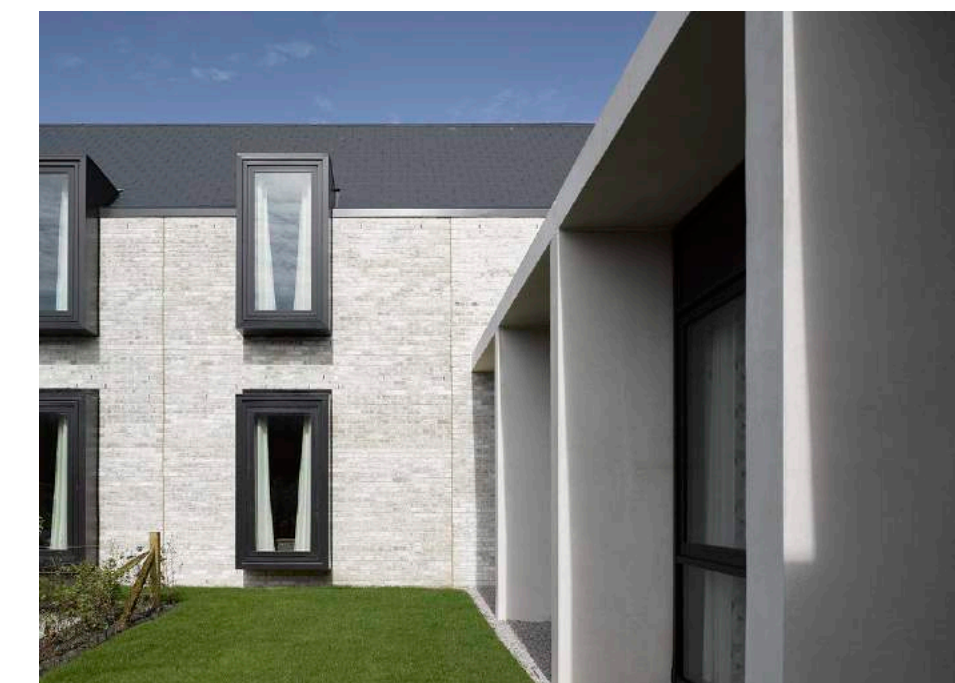
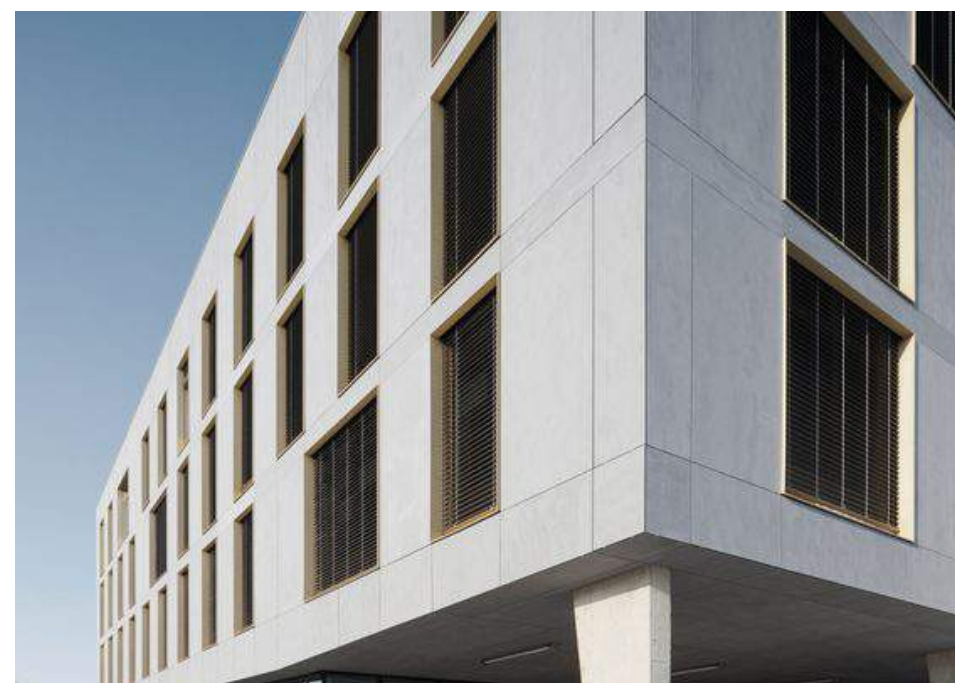
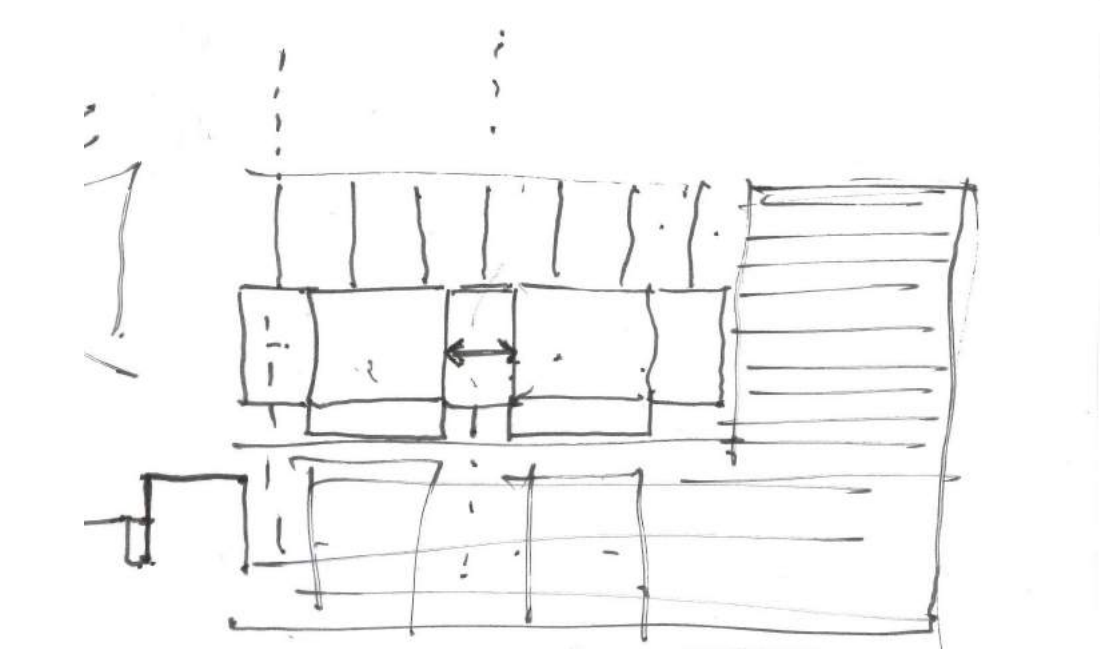
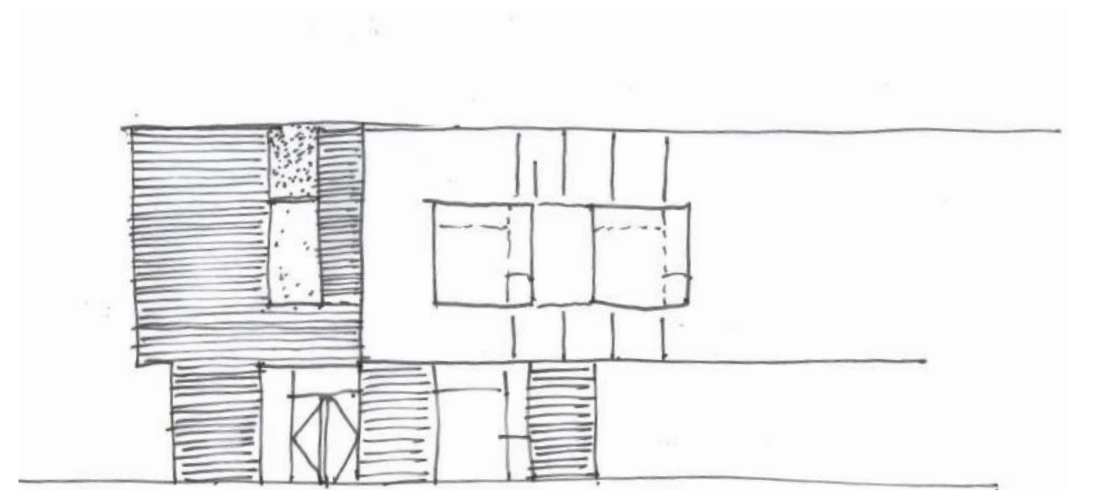

PRECEDENT IMAGES OF MATERIALS AND DETAILING THAT IS BEING CONSIDERED

THE PROPOSAL

The proposed school elevations.



NORTH EAST ELEVATION

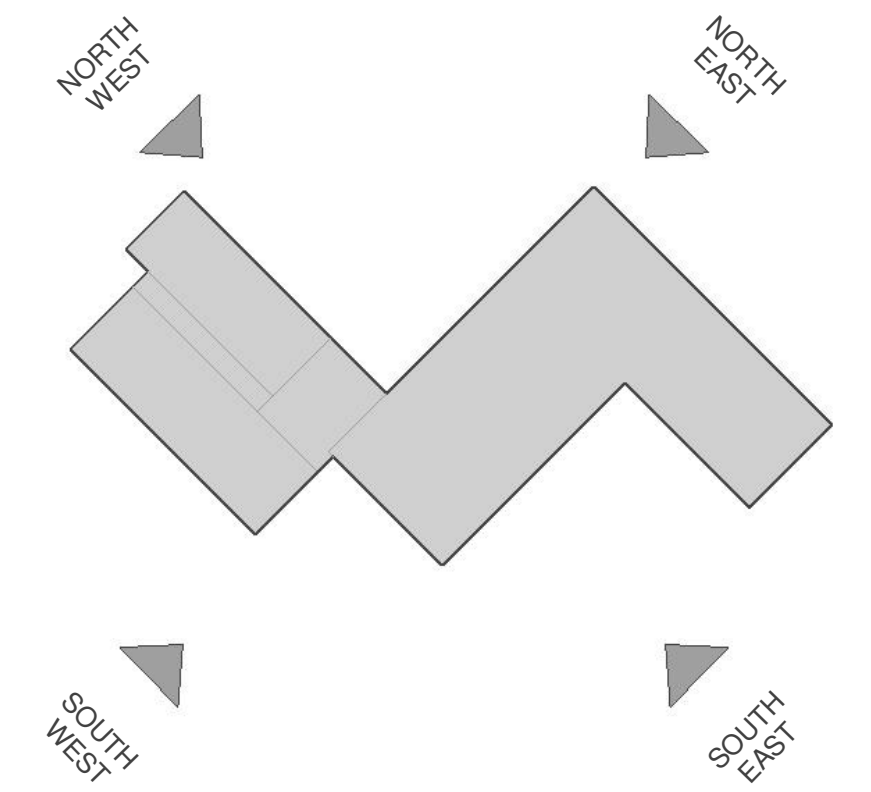

SOUTH EAST ELEVATION



NORTH WEST ELEVATION



SOUTH WEST ELEVATION



PRECEDENT IMAGES OF MATERIALS AND DETAILING THAT IS BEING CONSIDERED



INTERNAL PRECEDENT IMAGES

ALNESS ACADEMY THE PROCESS

How the construction site will run alongside the existing school.

SITE COMPOUND (PHASE 2 - ALNESS ACADEMY CONSTRUCTION)



SCHOOL CAR PARK, DELIVERIES AND ACCESS MAINTAINED DURING PHASE 1 & 2



SITE COMPOUND (PHASE 1 - SPORTS PITCH FORMATION)



ACTIVE SITE FENCE LINE (PHASE 1 - SPORTS PITCH FORMATION)

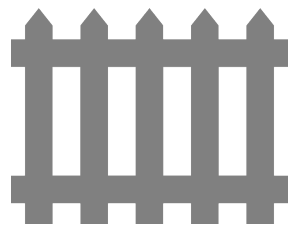

EXISTING BUS DROP OFF RETAINED



PROPOSED SCHOOL FOOTPRINT



ACTIVE SITE FENCE LINE (PHASE 2 - ALNESS ACADEMY CONSTRUCTION)

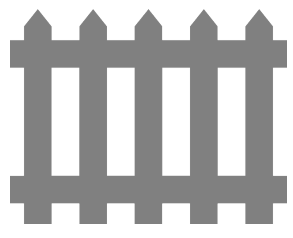

CONSTRUCTION SITE ACCESS, DELIVERIES, ETC

