

T:\001\_Design Team\2003\_Small\_Schemes\_Projects\HMS3001 Safer Routes To School\2021 - 2022 Schemes\Milton Primary - YCHMS3022\DRAWINGS\CAD\LIVE\YCHMS3022\_LIVE\_01.dwg 03/03/2023 ANSIA (8.50 x 11.00 Inches)

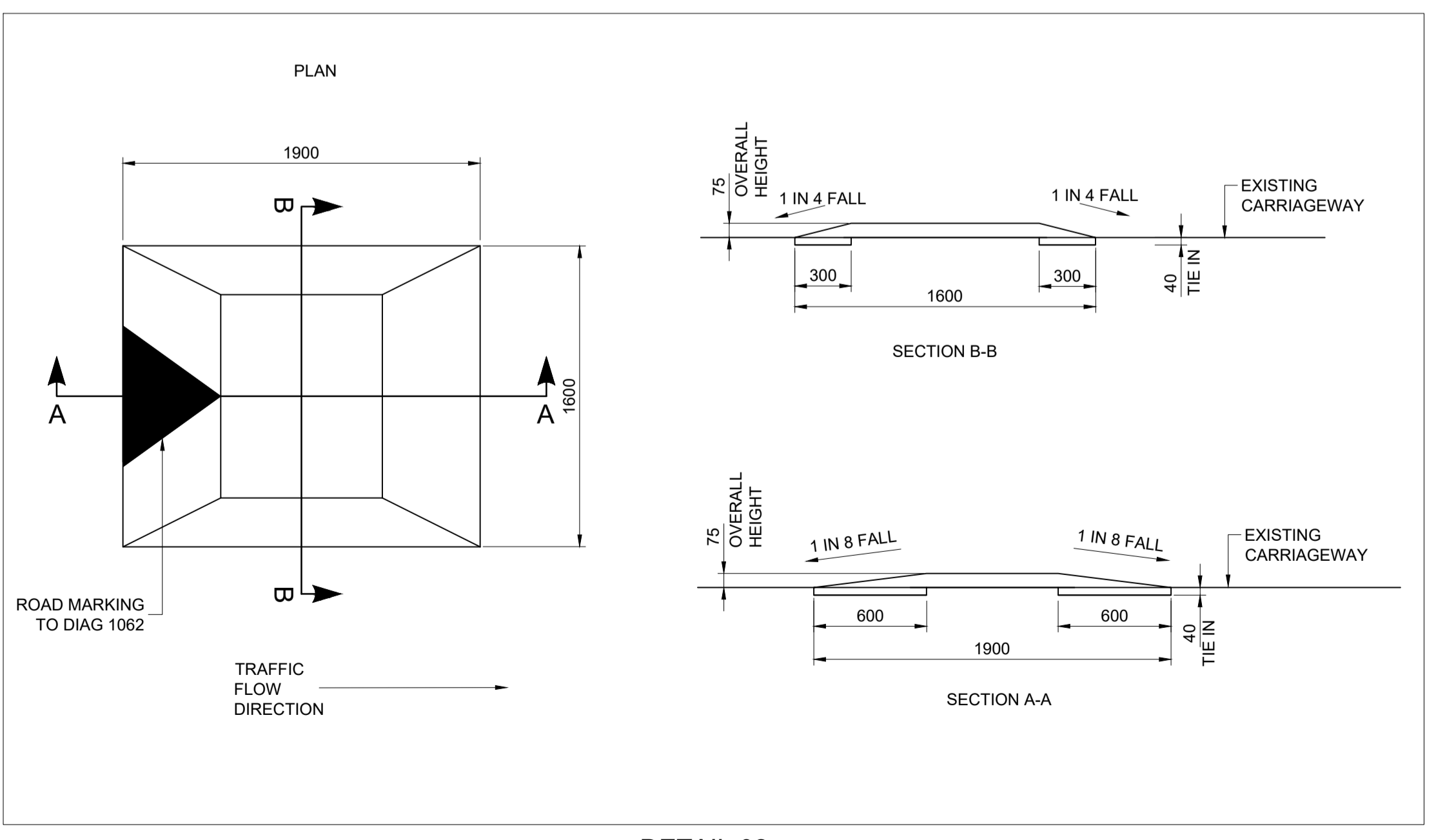
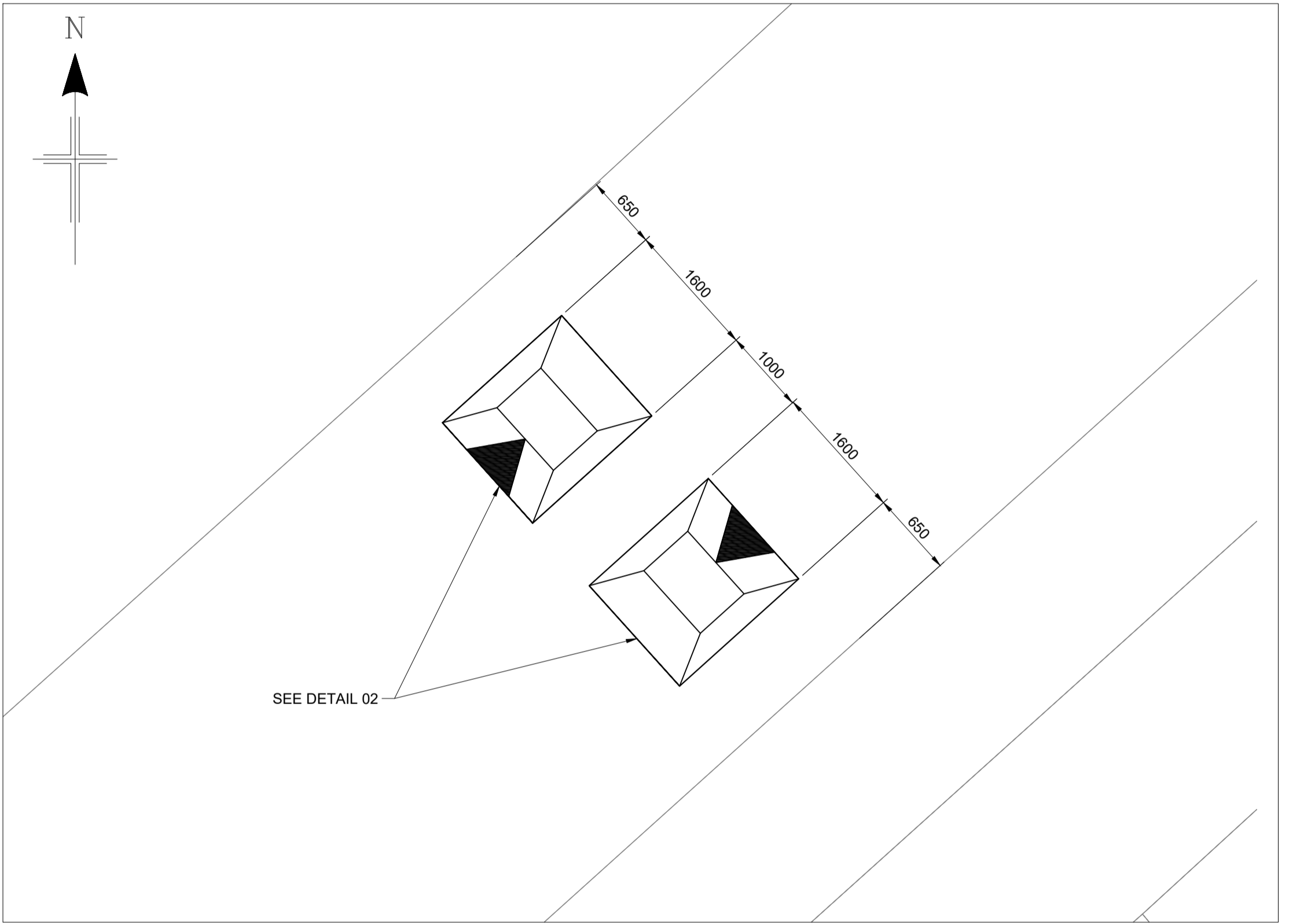
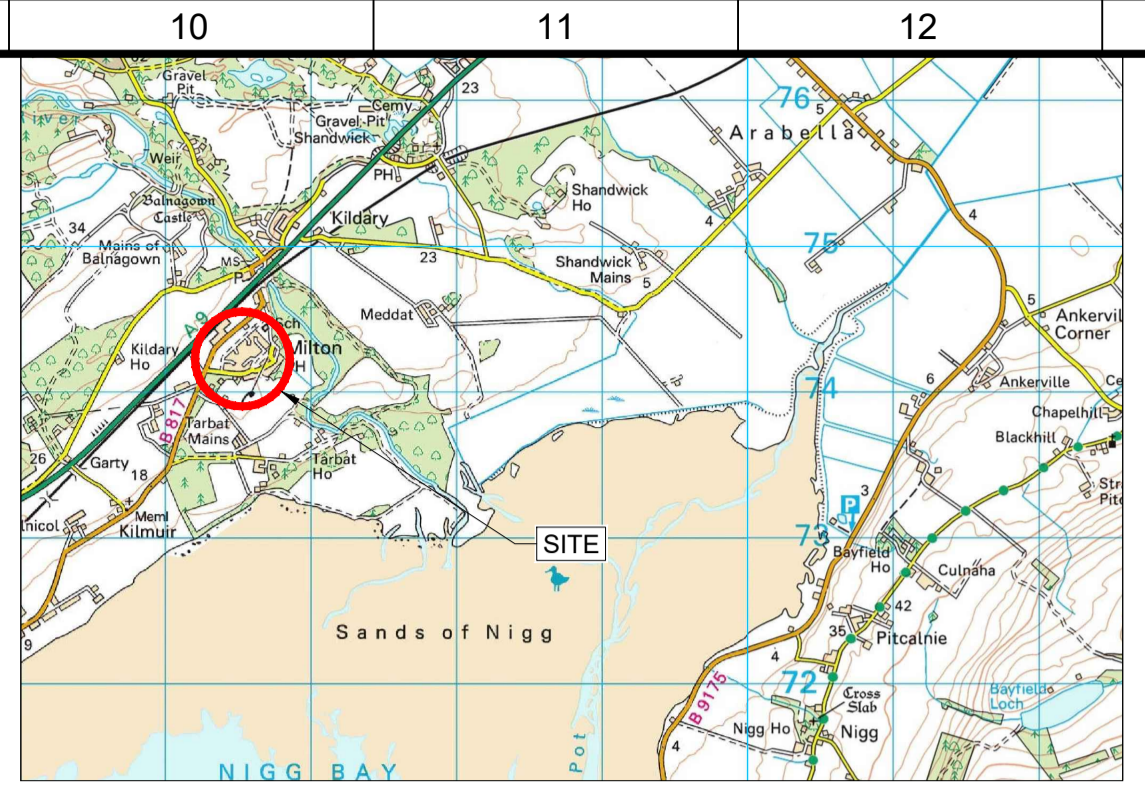
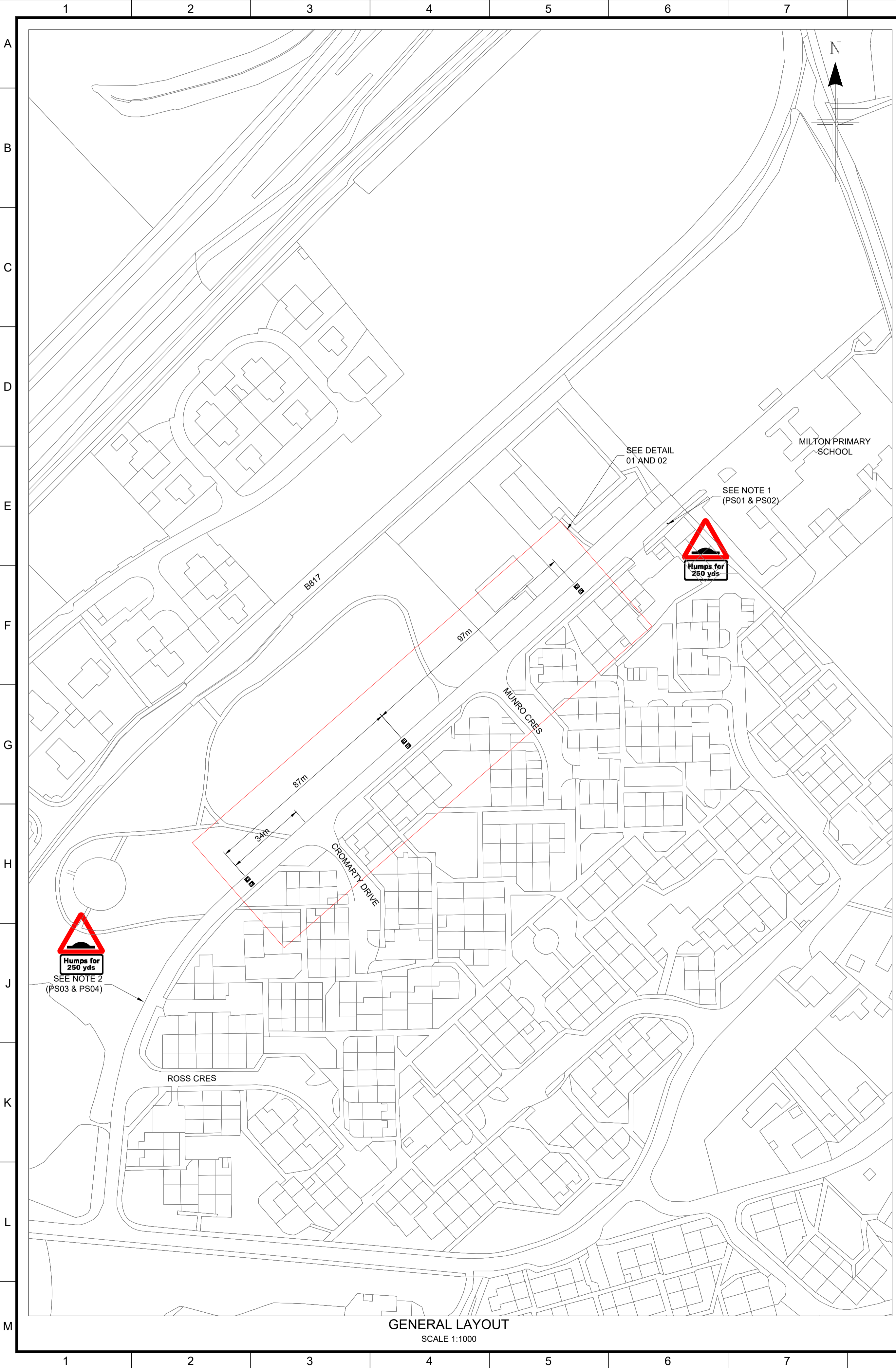

COPYRIGHT, DESIGNS and PATENTS ACT 1986:  
THIS DRAWING MAY NOT BE REPRODUCED, COPIED OR USED IN ANY WAY WITHOUT THE WRITTEN PERMISSION OF THE DIRECTOR OF DEVELOPMENT AND INFRASTRUCTURE.  
© THE HIGHLAND COUNCIL  
© CROWN COPYRIGHT AND DATABASE RIGHTS 2019 OS 100023369. YOU ARE GRANTED A NON-EXCLUSIVE, ROYALTY FREE, REVOCABLE LICENCE SOLELY TO VIEW THE LICENSED DATA FOR NON-COMMERCIAL PURPOSES FOR THE PERIOD WHICH THE HIGHLAND COUNCIL MAKES IT AVAILABLE. YOU ARE NOT PERMITTED TO COPY, SUB-LICENSE, DISTRIBUTE, SELL OR OTHERWISE MAKE AVAILABLE THE LICENSED DATA TO THIRD PARTIES IN ANY FORM. THIRD PARTY RIGHTS TO ENFORCE THE TERMS OF THIS LICENCE SHALL BE RESERVED TO THE OS.

DO NOT SCALE FROM DRAWING.  
ALL DIMENSIONS ARE IN mm UNLESS OTHERWISE STATED.

- NOTES**
- PS01 - DIAG 557.1 (ROAD HUMPS)  
PS02 - DIAG 572 (SUB PLATE - Humps for 250 yds) WITH NEW SIGN POST AND FOUNDATION
  - PS03 - DIAG 557.1 (ROAD HUMPS)  
PS04 - DIAG 572 (SUB PLATE - Humps for 250 yds) TO BE INSTALLED TO EXISTING LAMP POST

1	CONSULTATION ISSUE	ALG	BS	03/03/23
REV	REVISION DETAILS	DRAWN BY	CHECK BY	DATE

**The Highland Council**  
**Comhairle na Gàidhealtachd**

**INFRASTRUCTURE, ENVIRONMENT & ECONOMY**

PROJECT DESIGN UNIT  
COUNCIL BUILDINGS  
HIGH STREET  
DINGWALL IV15 9QN

PHONE: 01349 868800  
E-MAIL: PDU.DT2@highland.gov.uk

**PROJECT**  
**CYCLING, WALKING AND SAFER STREETS AT MILTON PRIMARY SCHOOL**

**TITLE**  
**INSTALLATION OF SPEED CUSHIONS (3No)**

	SCALE <b>AS SHOWN</b>	ORIGINAL SIZE A1 (594 x 841)
DRAWN ALG	DATE 03/03/23	
CHECKED BS	DATE 03/03/2023	

PROJECT No.	<b>YCHMS3022</b>
DRAWING No.	<b>101</b>
REVISION	<b>1</b>