



**ROADS AND TRANSPORT GUIDELINES FOR
NEW DEVELOPMENTS**

**STIÙIRIDHEAN RATHAIDEAN IS CÒMHDHAIL
AIRSON LEASACHAIDHEAN ÙRA**

**THE HIGHLAND COUNCIL
COMHAIRLE NA GÀIDHEALTACHD**

Produced by Highland Council Transport, Environmental and Community Services
with assistance from Halcrow Group Ltd

May 2013

| CONTENTS / CLÀR-INNSE | PAGE / DUILLEAG |
|--|------------------------|
| Contents / Clàr-innse | 2 |
| Introduction / Ro-ràdh | 8 |
| Glossary / Beag-fhaclair | 11 |
| List of Figures / Liosta Fhigearan | 15 |
| List of Tables / Liosta Chlàran | 16 |
| <u>Section 1 – Policy and Procedures / Earrann 1 – Poileasaidh agus Modhan</u> | |
| Section 1 Preamble / Earrann 1 Ro-ràdh | 18 |
| Chapter 1 Policy / Caibideal 1 Poileasaidh | 19 |
| 1.1 Introduction and General Requirements / Ro-ràdh agus Riatanasan Coitcheann | 19 |
| 1.2 National Policy and Guidance / Poileasaidh agus Stiùireadh Nàiseanta | 20 |
| 1.3 Council Policy and Guidance / Poileasaidh agus Stiùireadh na Comhairle | 20 |
| 1.4 New Residential and Mixed Use Development / Leasachadh Ùr Còmhnaidheach agus Cleachdadh Measgaichte | 21 |
| 1.5 Development in the Countryside / Leasachadh air an Dùthaich | 22 |
| Chapter 2 Planning / Caibideal 2 Dealbhadh | 23 |
| 2.1 Planning applications / Iarrtasan dealbhaidh | 23 |
| 2.1.1 General | 23 |
| 2.1.2 Pre-application consultation and scoping | 25 |
| 2.1.3 Master planning | 26 |
| 2.1.4 Making a Planning Application | 26 |
| 2.1.5 Transport Considerations | 29 |
| 2.1.6 Drainage and Flooding | 31 |
| 2.2 Transport Forms, Statements and Assessments / Dòighean, Aithrisean agus Measaidhean Còmhhdhalach | 31 |
| 2.2.1 Transport Forms | 31 |
| 2.2.2 Transport Statements | 31 |
| 2.2.3 Transport Assessments | 31 |
| 2.3 Travel Plans / Planaichean Còmhhdhalach | 33 |
| 2.4 Meeting the Needs of People with Disabilities / A' Coinneachadh ri Feumalachdan Dhaoine le Ciorraman | 34 |
| Chapter 3 Road Construction Consent and Traffic Orders | 35 |
| Caibideal 3 Aonta Togail Rathaid agus Òrdughan Traftaig | |
| 3.1 Road Construction Consent Applications / Iarrtasan airson Aonta Togail Rathaid | 35 |
| 3.1.1 General | 35 |
| 3.1.2 Private Access | 36 |
| 3.1.3 Residential Developments | 36 |
| 3.1.4 Access for Other Developments | 37 |
| 3.1.5 Works on an Existing Public Road | 37 |
| 3.1.6 Application for Road Construction Consent | 38 |
| 3.1.7 Road Structures | 40 |
| 3.1.8 Drainage | 41 |
| 3.1.9 Road Safety Audits | 41 |
| 3.1.10 Responsibility for Design | 42 |
| 3.1.11 Soil Report | 42 |
| 3.1.12 Mineral/Geotechnical Report | 42 |
| 3.1.13 Docqueting of Plans | 42 |
| 3.1.14 Notice to Affected Parties | 42 |

| | |
|---|-----------|
| 3.1.15 Representations | 43 |
| 3.1.16 Hearing of Application | 43 |
| 3.1.17 Duration of Road Construction Consent | 43 |
| 3.1.18 Amendments to Road Construction Consent | 43 |
| 3.1.19 Road Bond | 44 |
| 3.1.20 Right of Appeal | 44 |
| 3.1.21 Offences | 44 |
| 3.1.22 Powers of the Local Roads Authority | 45 |
| 3.1.23 Inspection Fee Charges | 45 |
| 3.2 Inspection Procedures during Construction / Modhan Sgrùdaidh rè Togail | 45 |
| 3.2.1 Notice of Commencement | 45 |
| 3.2.2 Inspection and Testing | 46 |
| 3.2.3 Notice of Operations | 46 |
| 3.2.4 Substantial Completion of Works Inspection | 47 |
| 3.2.5 Reduction of Road Bond | 48 |
| 3.2.6 Construction (Design and Management) Regulations 2007 | 48 |
| 3.3 Adoption of New Development Roads, Footways, Cycle Tracks and Footpaths / Gabhail Thairis Leasachaidhean Ùra a thaobh Rathaidean, Slighean-coise, Slighean-baidhsagail agus Ceuman-coise | 48 |
| 3.3.1 Policy | 48 |
| 3.3.2 Phased Adoption | 48 |
| 3.3.3 Verges | 49 |
| 3.3.4 Footpaths and Shared Footpaths/Cycle Tracks | 49 |
| 3.3.5 Parking Areas | 49 |
| 3.3.6 Adoption of Road Lighting | 50 |
| 3.3.7 Adoption of Traffic Signals and Signs | 50 |
| 3.3.8 Road Structures Agreements | 51 |
| 3.4 Application for Adoption of New Roads and Footpaths / Iarrtas airson Gabhail Thairis Rathaidean is Ceuman-coise Ùra | 51 |
| 3.4.1 Application for Adoption | 51 |
| 3.4.2 Adoption Inspection | 52 |
| 3.4.3 Addition to List of Public Roads / | 52 |
| 3.4.4 Release of Road Bond | 52 |
| 3.5 Making Up and Adoption of Private Road / Dèanamh Suas is Gabhail Thairis Rathad Priobhaideach | 52 |
| 3.6 Traffic Orders / Òrdughan Trafaig | 53 |
| 3.6.1 Permanent Closures and Alterations to Public Roads | 53 |
| 3.6.2 Traffic Regulation Orders | 54 |
| <u>Section 2 – Standards and Guidelines / Earrann 2 Inbhean agus Stiùiridhean</u> | |
| Section 2 Preamble / Earrann 2 Ro-ràdh | 56 |
| Chapter 4 Road Network / Caibideal 4 Lionra Rathaidean | 57 |
| 4.1 Introduction / Ro-ràdh | 57 |
| 4.2 Road Types / Seòrsaichean Rathaid | 58 |
| 4.2.1 General | 58 |
| 4.2.2 The Highland Council Road Type Classification | 58 |
| 4.3 Descriptions / Tuairisgeulan | 60 |
| 4.3.1 Strategic Route, Main Distributor and Regional Route Roads | 60 |
| 4.3.2 Local Distributor Road | 60 |
| 4.3.3 Industrial Access Road | 60 |
| 4.3.4 Residential Streets | 61 |
| 4.3.5 Home Zones | 61 |
| 4.3.6 Private Accesses and Roads | 61 |
| 4.3.7 Roads in Rural Areas | 62 |
| 4.4 Pedestrian and Cycle Networks / Lionraidhean Choisichean is Bhaidhsagalan | 62 |
| 4.5 Bus Network / Lionra Bhusaichean | 63 |
| Chapter 5 Design Objectives and Requirements / Caibideal 5 Amasan agus Riatanasan Dealbhaidh | 65 |
| 5.1 Introduction / Ro-ràdh | 65 |

| | |
|--|-----|
| <i>Geometric Requirements for Roads and Junctions / Riatanasan Geoimeatrach airson</i> | |
| <i>Rathaidean is Chinn-rathaid</i> | |
| 5.2 Road Elements / Eileamaidean Rathaid | 66 |
| 5.3 Road Link Types / Seòrsachan Cheangalan Rathaid | 66 |
| 5.3.1 Strategic Route Roads and Main Distributor Roads | 66 |
| 5.3.2 Local Distributor Road | 66 |
| 5.3.3 Industrial Access Road | 67 |
| 5.3.4 Residential Streets | 68 |
| 5.3.5 Home Zones and Shared Surfaces | 68 |
| 5.3.6 Single Track Access Road | 69 |
| 5.4 Rural Residential Streets / Sràidean Còmhnaidheach Dùthchail | 69 |
| 5.5 Link Design Geometric Requirements / Riatanasan Geoimeatrach Dealbhadh Ceangail | 70 |
| 5.6 Road Junctions / Cinn-rathaid | 73 |
| 5.6.1 Introduction | 73 |
| 5.6.2 Junction Types | 73 |
| 5.6.3 Junction Spacing | 73 |
| 5.6.4 Junction Visibility | 73 |
| 5.6.5 Junction Design Standards | 74 |
| 5.6.6 Siting of Junctions and Accesses | 74 |
| 5.6.7 Long Vehicle Requirements | 74 |
| 5.7 Visibility / Lèirsinneachd | 77 |
| 5.7.1 Introduction | 77 |
| 5.7.2 Forward Visibility | 77 |
| 5.7.3 Visibility Splays at Junctions | 77 |
| 5.8 Carriageway Widening for Corners and Bends/ Leudachadh Rathaidean airson Oiseanan is Lùban | 81 |
| 5.9 Vehicle Clearance / Rùm-gluasaid Charbadan | 83 |
| 5.9.1 Vertical Clearance | 83 |
| 5.9.2 Horizontal Clearance | 84 |
| 5.10 Gradients / Caiseadan | 84 |
| 5.11 Turning Areas / Àiteachan Tionndaidh | 84 |
| 5.11.1 Introduction | 84 |
| 5.11.2 Residential Turning Areas | 85 |
| 5.11.3 Industrial Turning Areas | 87 |
| 5.11.4. Bus Turning Areas | 89 |
| 5.12 Rural Accesses / Slighean-inntrigidh Dùthchail | 89 |
| 5.13 Private Accesses and Driveways / Slighean-inntrigidh Prìobhaideach | 89 |
| 5.13.1 Introduction | 89 |
| 5.13.2 Private Accesses for Non-Residential Developments | 89 |
| 5.13.3 Access for Forestry Extraction | 90 |
| 5.13.4 Private Accesses and Driveways for Residential Dwellings | 90 |
| 5.14 Designing Roads for Low Speeds / A' Dealbhadh Rathaidean airson Astaran Ìseal | 91 |
| 5.14.1 Introduction | 91 |
| 5.14.2 Design | 91 |
| 5.14.3 Speed Limits | 91 |
| 5.14.4 Standard Traffic Calming Features | 92 |
| 5.14.5 Consultation | 93 |
| <i>Pedestrians, Cyclists and Equestrians / Coisichean, Luchd-baidhsagail is Marcaichean</i> | |
| 5.15 Pedestrians / Coisichean | 94 |
| 5.15.1 Introduction | 94 |
| 5.15.2 General Design Aspects | 94 |
| 5.15.3 Pedestrian Crossing Facilities | 95 |
| 5.15.4 Additional Design Considerations for Pedestrians | 100 |
| 5.15.5 Footway Widths Adjacent to Carriageways | 104 |
| 5.15.6 Footpath Widths Remote from Roads | 105 |
| 5.16 Cyclists / Luchd-baidhsagail | 106 |
| 5.16.1 Introduction | 106 |
| 5.16.2 Link Design | 107 |

| | |
|---|-----|
| 5.16.3 Cycle Facility Road Crossings and Junctions | 111 |
| 5.16.4 Additional Design Issues for Cyclists | 112 |
| 5.17 Provision for Equestrians / <i>Ullachadh airson Mharcaichean Public Transport / Còmhdhail Phoblach</i> | 113 |
| 5.18 Public Transport Facilities / <i>Goireasan Còmhdhail Phoblaich</i> | 114 |
| 5.18.1 Introduction | 114 |
| 5.18.2 Bus Routes | 114 |
| 5.18.3 Road Widths for Bus Routes | 116 |
| 5.18.4 Bus Stops and Shelters | 116 |
| 5.18.5 Bus Boarders | 118 |
| 5.18.6 Bus Bays | 118 |
| 5.18.7 Lighting at Bus Stops | 119 |
| 5.18.8 Bus Turning Facilities | 119 |
| 5.18.9 Bus Priority Measures | 120 |
| 5.18.10 Real Time Information | 120 |
| 5.18.11 Taxis | 120 |
| 5.18.12 Trains | 120 |
| | |
| <i>Servicing Arrangements / Ullachaidhean Seirbheis</i> | |
| 5.19 Servicing Arrangements / <i>Ullachaidhean Seirbheis</i> | 121 |
| 5.19.1 Introduction | 121 |
| 5.19.2 Commercial and Industrial Developments | 121 |
| 5.19.3 Loading Bays | 121 |
| 5.19.4 Service Roads and Ramps | 123 |
| 5.19.5 Parking | 124 |
| 5.19.6 Fire Fighting Vehicles | 124 |
| 5.19.7 Refuse Collection Requirements | 125 |
| 5.19.8 Gully Emptying | 125 |
| 5.19.9 Winter Maintenance | 125 |
| | |
| <i>Traffic Signs and Road Markings, Road Lighting, Traffic Signals and Statutory Undertakers Soidhnichean Trafaig is Comharran Rathaid, Soillseachadh Rathaid, Teachdaireachdan Trafaig agus Gabhail Os Làimh Reachdail</i> | |
| 5.20 Traffic Signs and Road Markings <i>Soidhnichean Trafaig is Comharran Rathaid</i> | 127 |
| 5.21 Road Lighting / <i>Soillseachadh Rathaid</i> | 128 |
| 5.21.1 Introduction | 128 |
| 5.21.2 Design Requirements | 128 |
| 5.21.3 Location of Equipment | 129 |
| 5.21.4 Existing Services | 129 |
| 5.21.5 Defective Equipment Prior to Adoption | 129 |
| 5.22 Traffic Signals/ <i>Teachdaireachdan Trafaig</i> | 130 |
| 5.22.1 Introduction | 130 |
| 5.22.2 Design Requirements | 130 |
| 5.22.3 Installation – General Requirements | 132 |
| 5.22.4 Maintenance Costs | 132 |
| 5.23 Statutory Undertakers / <i>Gabhail Os Làimh Reachdail</i> | 134 |
| 5.23.1 Introduction | 134 |
| 5.23.2 Locations | 134 |
| 5.23.3 Service Strips | 134 |
| 5.23.4 Design Requirements | 136 |
| 5.23.5 Council and Statutory Undertakers' Access Rights | 137 |
| 5.23.6 General Construction Requirements | 138 |
| | |
| <i>Structures / Structaran</i> | |
| 5.24 Structures / <i>Structaran</i> | 139 |
| | |
| <i>Road Drainage / Drèanadh Rathaid</i> | |
| 5.25 Road Drainage / <i>Drèanadh Rathaid</i> | 140 |
| 5.25.1 Introduction | 140 |
| 5.25.2 Sustainable Urban Drainage Systems | 141 |
| 5.25.3 Design Requirements | 142 |

| | |
|--|------------|
| 5.25.4 Drainage Connection | 144 |
| 5.25.5 Sub-grade Drainage | 144 |
| 5.25.6 Drainage Impact Assessment | 145 |
| 5.26 Flooding Issues / <i>Ceistean Thuiltean</i> | 145 |
| <i>Other Design Requirements / Riatanasan Dealbhaidh Eile</i> | |
| 5.27 Other Design Requirements / <i>Riatanasan Dealbhaidh Eile</i> | 146 |
| 5.27.1 Access to Play Areas | 146 |
| 5.27.2 Traffic Noise | 146 |
| 5.27.3 Safety Barriers and Fences | 146 |
| 5.27.4 General Construction Traffic | 147 |
| 5.27.5 Special Features | 147 |
| Chapter 6 Parking / <i>Caibideal 6 Parcadh</i> | 148 |
| 6.1 Introduction / <i>Ro-ràdh</i> | 148 |
| 6.2 Policy and Objectives / <i>Poileasaidh agus Amasan</i> | 148 |
| 6.2.1 National Policy | 148 |
| 6.2.2 Council Policy and Objectives | 148 |
| 6.3 Parking Design / <i>Dealbhadh Parcaidh</i> | 149 |
| 6.3.1 General | 149 |
| 6.3.2 Residential Developments | 149 |
| 6.3.3 Non-Residential Developments | 152 |
| 6.3.4 Parking Bay Design | 153 |
| 6.3.5 Parking for Persons with Mobility Difficulties | 156 |
| 6.3.6 Cycle Parking | 158 |
| 6.3.7 Motorcycle Parking | 159 |
| 6.4 Parking Standards / <i>Inbhean Parcaidh</i> | 160 |
| 6.4.1 Introduction | 160 |
| 6.4.2 Parking Standards Tables | 161 |
| Chapter 7 Construction Materials Standards / <i>Caibideal 7 Inbhean Stuthan Togail</i> | 173 |
| 7.1 General / <i>Coitcheann</i> | 173 |
| 7.2 Geotechnical Requirements / <i>Riatanasan Geo-teicnigeach</i> | 173 |
| 7.3 Road Drainage / <i>Drèanadh Rathaid</i> | 174 |
| 7.4 Pavement Construction / <i>Togail Chabhsairean</i> | 175 |
| 7.4.1 Carriageways | 175 |
| 7.4.2 Footways, Footpaths and Cycle Tracks | 180 |
| 7.4.3 Vehicular Footway Crossings | 182 |
| 7.5 Kerbing and Edging / <i>Oirean Chabhsairean</i> | 183 |
| 7.6 Landscaping and verges / <i>Dealbhadh-tìre agus Fàil Rathaid</i> | 184 |
| <u>Section 3 – Flooding and Construction Traffic / <i>Earrann 3 – Tuiltean agus Trafaig Togail</i></u> | |
| Section 3 Preamble / <i>Earrann 3 Ro-ràdh</i> | 188 |
| Chapter 8 Flooding / <i>Caibideal 8 Tuiltean</i> | 189 |
| 8.1 General / <i>Coitcheann</i> | 189 |
| 8.2 Legislation / <i>Reachdas</i> | 189 |
| 8.2.1 Flood Risk Management (Scotland) Act 2009 | 189 |
| 8.2.2 Planning | 190 |
| 8.2.3 Controlled Activities (Scotland) Regulations 2005 | 191 |
| 8.2.4 Coast Protection Act 1949 | 191 |
| 8.3 Management of Flood Risk for New Developments and Infrastructure / <i>Rianachd Cunnart Thuiltean airson Leasachaidhean is Bun-structair Ùr</i> | 191 |
| 8.3.1 Introduction | 191 |
| 8.3.2 Initial Flood Risk Assessment | 192 |
| 8.3.3 Detailed Flood Risk Assessment | 192 |
| 8.3.4 Drainage | 193 |
| 8.3.5 Water Environment | 193 |
| 8.4 General Design Requirements / <i>Riatanasan Dealbhaidh Coitcheann</i> | 194 |

| | |
|---|------------|
| Chapter 9 Construction Traffic / Caibideal 9 Trafaig Togail | 195 |
| 9.1 Introduction / Ro-ràdh | 195 |
| 9.2 Abnormal Loads / Eallaichean Neo-àbhaisteach | 195 |
| 9.3 Renewable Energy Developments / Leasachaidhean Lùth Ath-nuadhachail | 196 |
| 9.3.1 Onshore Wind Farms | 196 |
| 9.3.2 Other Types of Renewable Energy Developments | 196 |
| 9.3.3 General Disturbance | 197 |
| 9.4 Wear and Tear Agreements / Aontaidhean a thaobh Caitheamh Àbhaisteach | 197 |

Appendices / Eàrr-ràdhan 199

| | |
|--------------|---|
| Appendix 1 | Roads and Community Works Area Offices |
| Eàrr-ràdh 1 | Oifisean Sgìreil Rathaidean agus Obraichean Coimhearsnachd |
| Appendix 2 | Planning and Building Standards Offices |
| Eàrr-ràdh 2 | Oifisean Inbhean Dealbhaidh agus Togail |
| Appendix 3 | Transportation Assessment TA1 Form |
| Eàrr-ràdh 3 | Foirm TA1 Measadh Còmhdhalach |
| Appendix 4 | Travel Plan Guidance |
| Eàrr-ràdh 4 | Stiùireadh Plana Còmhdhalach |
| Appendix 5 | RCC Application Forms |
| Eàrr-ràdh 5 | Foirmean-iarrtais Gèilleadh Togail Rathaid |
| Appendix 6 | RCC Construction Compliance Form |
| Eàrr-ràdh 6 | Foirm-gèillidh Aonta Togail Rathaid |
| Appendix 7 | Public Transport Bus Stop Specification |
| Eàrr-ràdh 7 | Sònrachadh Stad Bus Còmhdhail Phoblaich |
| Appendix 8 | Refuse and Recycling Collection Requirements |
| Eàrr-ràdh 8 | Riathanasan Togail Sgudail is Ath-chuairteachaidh |
| Appendix 9 | Abnormal Loads |
| Eàrr-ràdh 9 | Eallaichean Neo-àbhaisteach |
| Appendix 10 | Access to Single Houses and Small Developments Booklet |
| Eàrr-ràdh 10 | Leabhran mu Shlighean-inntrigidh gu Taighean Singilte agus Leasachaidhean Beaga |
| Appendix 11 | Access for Forestry Extraction |
| Eàrr-ràdh 11 | Slighe airson Às-tharraing Coilltearachd |
| Appendix 12 | Parking Places for Disabled Persons |
| Eàrr-ràdh 12 | Àiteachan Parcaidh do Dhaoine Ciorramach |

Bibliography / Clàr-leabhraichean

INTRODUCTION / RO-RÀDH

Aim of the Document

This document sets out the guidance and standards for the provision of transport infrastructure, including the design and construction of all new roads, associated with development proposals, within The Highland Council area.

These Guidelines aim to ensure new roads are safe whilst, at the same time, ensuring new developments also provide transport facilities that are convenient for all types of road user as well as creating a high quality environment.

The Guidelines also apply to a developer who proposes alterations to an existing public road.

The Guidelines also sets out the procedures to be followed in order to ensure that new roads achieve acceptable standards so that the Council can subsequently adopt them as suitable public roads.

In addition, there is an associated requirement to measure and assess the transportation impact of any development proposal, so the design fully meets the needs of pedestrians, cyclists, persons with mobility difficulties and public transport passengers. The document also highlights the important requirement to assess drainage and flood risk, where appropriate, and some associated guidance is provided.

These Guidelines will be used by the Council for assessing the transportation aspects of development and proposals for construction of new transport infrastructure.

This document replaces the Council's previous "Road Guidelines for New Developments".

General Requirements

Transportation matters for new developments should satisfy the relevant Roads Authority, being either the Highland Council for local roads or the Scottish Government's Transport Scotland Agency for Trunk Roads and, in certain situations, both.

These Guidelines are mainly concerned with those new roads that are prospectively adoptable by the Council as public roads. While the Guidelines are written for new developments on green field sites, the principles will also apply to the redevelopment of existing sites and for infill development in both rural and urban areas.

In acting for the Highland Council, the Director of Transport, Environmental and Community Services, reserves the right to vary requirements to suit particular local conditions, since the Council area is diverse in nature and character and the Guidelines cannot cover every situation.

Developers should note that as well as providing new roads or altering existing public roads, which comply with these Guidelines, they may be required to undertake additional measures or provide a financial contribution to a project. Such requirements, which could include provision of or contributions to items, such as play areas, Safer Routes to Schools measures, bus service enhancements and grit bins, would be clarified during the planning application stage and set out as conditions of consent.

As well as providing guidance on roads issues, this document also highlights drainage and flooding issues, as they are becoming increasingly problematic, as a result of climate change, and can have a significant impact on a development.

Access to Single Houses and Small Housing Developments

For small developments involving four houses or less or where a private access is envisaged instead of a public road, the range of issues to be addressed is reduced. In order to facilitate the preparation and processing of applications for this type of small development, it is considered helpful to incorporate the relevant requirements in an “Access to Single Houses and Small Developments” Booklet, which is attached as an appendix to this document but also available as a separate publication.

In certain circumstances, such as the provision of holiday accommodation, the Council may permit more than four residential units to be served by a private access. Advice should be sought from both the Local Planning Authority and Local Roads Authority to agree the status of any proposed vehicular access and relevant design standards, which should be included. In addition, especially within the urban area, the Council may require an existing public road to be extended even if the extension is only to serve up to four new houses.

It should be noted that accesses serving small developments of four or less houses would not generally be deemed prospectively adoptable. Owners of the premises served by the accesses that remain private should be aware that they would be responsible for future maintenance requirements.

However, the section of a private access formed within the boundary of an existing public road will be adopted by the Local Roads Authority and, therefore, must be subject to Council approval.

GLOSSARY / BEAG-FHACLAIR

“Adoption” of a road or footway means its addition to the list of publicly maintained roads in terms of Section 16 and 18 of the Roads (Scotland) Act 1984.

“Allocated Parking Spaces” are parking spaces or driveways which are for the exclusive use of the residents of the individual dwelling and their visitors.

“Boarder” is the narrowing of the carriageway constructed on only one side as an extension of or widening of the footway, for the specific intention of provision of a bus stop and associated facilities.

“Build Out” is the narrowing of the carriageway constructed on only one side as an extension of or adjacent to the verge, footway or cycle track.

“Building” includes any erection; however and with whatever material it is constructed from.

“Carriageway” the part of a road constructed for use by vehicular traffic. Auxiliary traffic lanes, passing places lay-bys and bus bays are included.

“Cattle Grid” has the meaning given by section 41(6) of the Roads (Scotland) Act 1984.

“Chicane” is a series of build-outs on alternate sides of the carriageway.

“Classified Road” shall be construed in accordance with section 11 of the Roads (Scotland) Act 1984.

“Commercial Access” is any Access to commercial premises or otherwise where the vehicle weight may exceed 1500kg.

“Common” has the same meaning as in the Acquisition of Land (Authorisation Procedure) (Scotland) Act 1947.

“Construction Consent” is approval given by the local roads authority in terms of Section 21 of the Roads (Scotland) Act 1984 for construction of a new, or extension of an existing road.

“Cycle Lane” is a lane marked on a carriageway which can be either Advisory or Mandatory. Mandatory cycle lanes cannot be used by motor vehicles.

“Cycle Route” is a recommended route available for use by cyclists. It may be shared with other traffic and segregated or un-segregated.

“Cycle track” is a right of way by pedal cycle only or by pedal cycle and foot.

“Days” means clear working days.

“Driveway” means private vehicular access serving a single house.

“Dropped Kerb” is a reduction in carriageway edge kerb height.

“Enactment” includes an enactment in this act or in a local or private act and a provision of an order, a scheme, regulations or any other instrument made under or confirmed by a public general local or private act.

“Developer” is the planning applicant principal.

“Footpath” is a way or means of passage for pedestrians only, generally across open spaces and not associated with a carriageway.

“Footway” is that portion of a road reserved exclusively for pedestrians and associated with a carriageway.

“Formation” is a sub-grade prepared for road construction.

“Footway Crossing” is a crossing of footway, via a dropped kerb to give vehicular access to premises or parking area.

“Frontage Access” is vehicular access to premises taken directly from the road which they front.

“Frontager” related to a road or proposed road, means the owner of any land fronting or abutting it.

“Improvement” related to a road, means the doing of anything for the benefit of road users, or any class of road users, beyond that which is essential to placing the road in a proper state of repair and includes the improvement of the amenity:

- (a) of the road; and
- (b) of land abutting on, or adjacent to, the road.

“Local Authority” means one of the 32 unitary authorities established in Scotland on 1 April 1996.

“Local Roads Authority” has the meaning given by paragraph (a) of the definition of “Roads Authority”.
“Maintenance” includes repair, and watering to allay dust but, without prejudice to subsection (1) of section 25 of the Local Government and Planning (Scotland) Act 1982 (restriction 1982 c. 43 of powers of local authorities as regards street cleansing) not such cleansing as a unitary authority is required by subsections (1) and (3) of section 25 to undertake.

“Notice” means notice in writing.

“Obstruction” includes obstruction of view of a driver of a vehicle.

“Occupier” means the person in occupation or having charge, management or control of land, either on his own account or as the agent of another person.

“Open Space” has the same meaning as in the Acquisition of Land (Authorisation Procedure) (Scotland) Act 1947 c. 42. 1947.

“Owner” (a) In relation to land means, subject to paragraph (b) below, the person for the time being entitled to receive, or who would, if the same were let, be entitled to receive, the rents of the land, and includes a trustee, factor, tutor or curator, and in the case of public or municipal property applies to the persons who whom the management thereof is entrusted; and;
(b) In relation to special roads (whether existing or proposed) includes any person who under the Lands Causes Acts would be entitled to sell and convey the land to promoters of an undertaking and also includes a lessee under a lease the unexpired portion of which exceeds three years.

“Pedal Cycle” means a cycle whose motive power is provided solely by the legs of its rider or riders or which complies with the requirements specified in Regulations 4 of the Electrically Assisted Pedal Cycles S.I.

“Private Access” provides no right of passage for the public and entry can be restricted by the owner. Private accesses will not require Construction Consent.

“Private Road” means (without prejudice to the definition in this subsection of “proposed public road”) a new road in the course of construction or proposed to be constructed, by or on behalf of a roads authority; or an existing road which is a prospective public road within the meaning of the Public Utilities Street Works Act 1950.

“Public Road” means a road which a Roads Authority has a duty to maintain.

“Road” means subject to subsection (3) below, any way (other than waterway) over which there is a public right of passage (by whatever means) and includes the road’s verge, and any bridge (whether permanent or temporary) over which, or tunnel through which, the road passes; and any reference to a

road includes a part thereof. Such traffic may be limited to prescribed classes. In appropriate circumstances the term “road” also applies to “streets” in urban areas.

“**Road Bond**” is a deposit lodged as a security with the Local Roads Authority before work commences on construction within a development.

“**Road Structure**” means bridge, culvert, retaining wall and other features as covered by the “Management of Highway Structures” Code of Practice.

“**Road Hump**” is any vertical change between 50 and 100mm, in the level of the carriageway which can take the form of either a curved arc or a flat top within ramps and can be constructed of any material. *(It should be noted that a number of Local Authorities specify a maximum height of 75mm for road humps, as recommended by the Department of Transport.)*

“Roads Authority”

(a) In relation to a road or proposed road other than any such as is mentioned in paragraph (b) of this definition, the local council within whose area the road is (such council being in the Roads (Scotland) Act 1984 referred to as a “local roads authority”) and

(b) In relation to a Trunk Road (whether existing or in course of construction) or, without prejudice to section 4 of the Roads (Scotland) Act 1984, to a special road provided by him under section 7(5) (or to be provided by him under section 7(5) (a) or (b) or to any other road constructed (or to be constructed) by him under section 19(1) of the Roads (Scotland) Act 1984, the Secretary of State; and references to “they” in relation to a roads authority shall be taken to related also to the Secretary of State.

“**Safety Audit**” is a systematic procedure to ensure road networks function as safely as possible.

“**Service Area**” provides a loading/unloading area for delivery vehicles.

“**Service Road**” is a road providing or giving access to servicing facilities.

“**Service Strip**” is a reservation for Statutory Undertaker services (gas, water, etc) normally located within the confines of footway or verge.

“**Shared Surface**” is a paved area for un-segregated use by both pedestrians and vehicles.

“**Special Road**” means a road provided or to be provided in accordance with a scheme under section 7 of the Roads (Scotland) Act 1984.

“**Special Road Authority**” has the meaning given in section 7(4) of the Roads (Scotland) Act 1984.

“**Statutory Undertakers**” has the same meaning as in section 214 of the Town and Country Planning (Scotland) Act 1997 including the Royal Mail Post Office Service and, except in sections 133 and 140(4) of the Roads (Scotland) Act, the operator of any telecommunications code system.

“**Sub-grade**” is a material on top of which a carriageway, footway footpath or parking area is constructed.

“**Telecommunications Apparatus**” is “the telecommunications code” and “telecommunications code system” have the same meanings as paragraph 1 of Schedule 4 to the Telecommunications Act 1984.

“**Tidal Waters**” has the same meanings as in section 35(1) of the Rivers (Prevention of Pollution) (Scotland) Act 1951.

“**Traffic**” includes pedestrians and animals, as well as vehicles.

“**Traffic Calming**” means designing a road, using physical measures, to alter road user behaviour creating driving speed more in keeping with the character of the area.

“**Traffic Sign**” means any object or device (permanent or temporary) for conveying to road users, or any specified class of traffic on roads, warnings, information, requirements or prohibitions of any description, as specified in the Road Traffic Regulation Acts.

“Transport Assessment” is an assessment of the accessibility of a development site by different modes of travel and consideration of the impact of traffic to and from a new development on the road and transportation network.

“Travel Plan” is a document setting out a package of measures, incentives and targets to reduce reliance on private car use.

“Trunk Road” means a road which is a trunk road by virtue of section 5 of the Roads (Scotland) Act 1984 or of an order or direction under that section or section 202 of the Town and Country Planning (Scotland) Act 1997.

“Unallocated Parking” is parking spaces which do not relate directly to any particular dwellings and are considered to be for the use of either residents or visitors on a “first come first served basis.

“Use” is in relation to a road, and includes crossing.

“Vehicle” means a vehicle of any description and includes a machine or implement of any kind drawn or propelled along roads (whether or not by mechanical power).

“Verge” is the landscaped part of a road adjacent to the carriageway and generally at substantially the same level. It may abut footways, cycle tracks and ditches.

“Visibility” is the intervisibility between vehicles or between vehicles and pedestrians. Where this crosses land beside the road the area must be kept clear of obstructions.

“Water Authority” is Scottish Water as set out in terms of The Water Industry Act 2002.

“Works” as regards any road include:

- a) Making an alteration to it;
- b) Breaking up or opening it;
- c) Constructing or laying anything under it;
- d) Building anything into it; and
- e) Carrying out any other operations of a like nature.

and similar expressions shall be construed accordingly.

LIST OF FIGURES / LIOSTA FHIGEARAN

| | | page |
|--------------|--|-------------|
| Figure 2.1 | Planning Application Process Summary Flowchart | 22 |
| Figure 5.1 | Single Track Access Road Passing Place – Standard and Large | 65 |
| Figure 5.2 | Visibility Splays at a Priority Junction | 74 |
| Figure 5.3 | Minor Road Approach Visibility Splay | 75 |
| Figure 5.4 | Cross Corner Visibility Radius | 76 |
| Figure 5.5 | Driveway Visibility for Pedestrians | 77 |
| Figure 5.6 | Carriageway Widening on Corners | 79 |
| Figure 5.7 | Standard Turning Areas for Residential Streets | 82 |
| Figure 5.8 | Standard Turning Areas for Industrial Areas | 84 |
| Figure 5.9 | Controlled Pedestrian Crossing Arrangement | 94 |
| Figure 5.10a | Flush Dropped Kerbs at a Controlled Pedestrian Crossing | 95 |
| Figure 5.10b | Flush Dropped Kerbs at an Uncontrolled Pedestrian Crossing | 96 |
| Figure 5.11 | Cycle Lane Priority Crossing | 107 |
| Figure 5.12 | Standard Bus Bays – Rural and Urban | 115 |
| Figure 5.13 | Side Loading Bay | 118 |
| Figure 5.14 | End Loading Bays | 119 |
| Figure 5.15 | Curve Widening on Service Ramps | 120 |
| Figure 5.16 | Typical Layout of a Signal Controlled Priority Junction | 129 |
| Figure 5.17 | Recommended Statutory Utility Locations within the Service Strip | 131 |
| Figure 6.1 | Private Garage/Car Port Set-back Arrangement | 147 |
| Figure 6.2 | Off-Street Parking Layouts | 150 |
| Figure 6.3a | Public Parking Bays at Right Angles to a Road | 151 |
| Figure 6.3b | Private Parking Bays at Right Angles to a Road | 152 |
| Figure 6.4 | Parking spaces for Disabled Persons (desirable markings) | 153 |
| Figure 6.5 | Cycle Rack Stands – Typical Dimensions and Spacings | 154 |
| Figure 7.1 | Kerbing for Access Roads and Bus Routes | 180 |
| Figure 7.2 | Kerbing for Residential Areas and Car Parks | 180 |

LIST OF TABLES / LIOSTA CHLÀRAN

| | Page | |
|-------------------|--|-----|
| Table 2.1 | Summary of Planning Application Supporting Documentation | 26 |
| Table 4.1 | The Highland Council New Road Type Classification | 55 |
| Table 4.2 | Residential Streets User Hierarchy | 57 |
| Table 5.1 | Geometric Requirements for Urban Road Links | 67 |
| Table 5.2 | Geometric Requirements for Rural Road Links | 68 |
| Table 5.3 | Junction Design Standards for Priority Junctions – Urban | 71 |
| Table 5.4 | Junction Design Standards for Priority Junctions – Rural | 72 |
| Table 5.5 | Indicative Y Dimensions for Rural Speed Values | 72 |
| Table 5.6 | Cross Corner Visibility Requirements | 76 |
| Table 5.7 | Carriageway Widening on Curves of Small Radii | 78 |
| Table 5.8 | Minimum Footway Widths | 101 |
| Table 5.9 | Minimum Footpath Widths | 101 |
| Table 5.10 | With-flow Cycle Lane Widths | 104 |
| Table 5.11 | Segregated Cycle Track Facility Effective Widths | 105 |
| Table 5.12 | Clearance Distances to Fixed Objects | 106 |
| Table 5.13 | Traffic Signal Design Reference Documents | 126 |
| Table 5.14 | Gully Spacings for Carriageways | 138 |
| Parking Standards | | |
| Table 6.1 | Residential Developments | 158 |
| Table 6.2 | Healthcare, Education and Community Developments | 159 |
| Table 6.3 | Leisure Developments | 160 |
| Table 6.4 | Hotels, Restaurants/Cafes, Pubs and Function Rooms | 161 |
| Table 6.5 | Places of Assembly | 162 |
| Table 6.6 | Retail Developments | 163 |
| Table 6.7 | Commercial/Industrial Developments | 164 |
| Table 6.8 | Motor trade Developments | 165 |
| Table 6.9 | Cycle Parking | 166 |
| Table 6.10 | Motorcycle Parking | 167 |
| Table 6.11 | Car Parking for Disabled Persons | 168 |
| Table 7.1 | Carriageway Pavement Construction | 174 |
| Table 7.2 | Block Paving Carriageways | 176 |
| Table 7.3 | Footway/Footpath/Cycle Track Construction | 177 |
| Table 7.4 | Vehicular Footway Crossing Construction | 178 |

SECTION 1 – POLICY AND PROCEDURES
/ EARRANN 1 – POILEASAIDH AGUS MODHAN

Section 1 of this document describes the processes involved in satisfying the transportation aspects of planning applications and in obtaining the necessary consents that are required before a new road is constructed and, thereafter, adopted as a public road by The Highland Council, acting in its role as Local Roads Authority.

Section 1 includes the following:-

Chapter 1 – Policy

Chapter 2 – Planning

Chapter 3 – Road Construction Consent and Traffic Orders

CHAPTER 1 – POLICY / CAIBIDEAL 1 – POILEASaidH

1.1 Introduction and General Requirements / Ro-ràdh agus Riatanasan Coitcheann

1.1.1 This document sets out the Highland Council's requirements for:-

- the overall transport requirements for new development;
- the design and construction requirements for new roads which may be adopted by the Council;
- the assessment of flood risk and associated mitigation.

1.1.2 The Highland Council's function as Planning Authority¹ is undertaken by the Planning and Development Service while the functions of Local Roads Authority and Local Flood Authority are undertaken by Transport, Environmental and Community Services (TEC Services). The term 'the Council' is used subsequently within this document to cover all of its functions and roles.

1.1.3 The Planning and Development Service will consult with TEC Services on the transport and flooding implications of planning applications. When assessing an application for planning permission, the Council will require to be satisfied on a range of transport issues, including the accessibility of the proposed development, provision for pedestrians, cyclists, public transport, private cars and service vehicles, parking and the traffic impact on the existing road network, together with proposals for mitigation measures. The national and Council policies and standards which determine the circumstances and extent to which these need to be considered are set out in this document. The Planning and Development Service may also consult with Transport Scotland in respect of applications which have an impact on the trunk road network for which different standards are applicable.

1.1.4 TEC Services is responsible for setting standards for the construction of new roads proposed for adoption and controls this through the issue of Road Construction Consent for which the appropriate design and construction standards are set out in this document. In addition where existing roads are to be improved as part of a development, procedures are in place to ensure the Council's requirements are met.

1.1.5 Prior to the construction of any new road, a developer is required to obtain both Planning Permission and Road Construction Consent. It should be noted that formal Road Construction Consent will not normally be granted until detailed planning permission has been obtained.

1 For developments within the Cairngorm National Park, the Park Authority may call in applications for its determination and thereby become the Planning Authority rather than the Council.

1.2 National Policy and Guidance / Poileasaidh agus Stiùireadh Nàiseanta

1.2.1 The key national policy framework relating to the transport and flooding implications of proposed development is set out within the following documents (web links are provided in the Bibliography) and it is expected that proposals submitted to the Council shall generally be in accordance with these:-

- **Scottish Planning Policy** sets out the Scottish Government's policy on nationally important land use planning matters. These include transport and flooding;
- **Planning Advice Note PAN75: Planning for Transport** and **Planning: Transport Assessment and Implementation: A Guide** provides good practice guidance;
- **Roads (Scotland) Act 1984** sets out the powers and responsibilities of the Council as Local Roads Authority, and provides the basis on which roads are adopted and on the issuing of Roads Construction Consent;
- **Designing Streets** sets out policy and guidance on the design of urban streets, particularly residential and other lightly trafficked streets. For a discussion of the relationship of Designing Streets to the guidance given in this document refer to section 1.4 below;
- **Design Manual for Roads and Bridges (DMRB)** sets out standards for trunk roads but these are also applicable in certain cases to non trunk roads. Generally where standards are given in this document they should be used on local roads in preference to the DMRB. However for some works, for example highway structures and when undertaking work on heavily trafficked roads, the DMRB standards are applicable, except where agreed otherwise with the Council;
- There are a number of other national policy documents relevant to planning issues and development. These can be accessed at www.scotland.gov.uk/Topics/Built-Environment/planning

1.3 Council Policy and Guidance

1.3.1 Council policies include the spatial and land use planning policies and strategies applicable to the Highland area. The Council policies generally augment and build upon the national policy framework. Proposals submitted to the Council are expected to take full recognition of the following:-

- **The Highland Wide Local Development Plan**, which provides details of strategic policies, with regard to issues such as land use, housing, transportation, business/industry, environment and tourism;
- **Local Development Plans**, which set out local planning policies within defined areas of the Council area;
- **Development Briefs**, which relate to defined development areas.
- **Highland Local Transport Strategy** sets out the Council's transportation policies.
- **Designing for Sustainability in the Highlands** sets out the Council's strong commitment to sustainability together with a number of other documents, which provide additional planning policy guidance.
- **Roads and Transport Guidelines for New Developments** (this document) sets out the detailed requirements for transport for new development together with requirements for new road construction.
- **Access to Single Houses and Small Housing Developments** sets out requirements for single houses and small groups of houses in the countryside which do not require a road adoption. The booklet also forms an appendix to the Roads and Transport Guidelines for New Developments (this document).

1.4 **New Residential and Mixed Use Development / Leasachadh Ùr Còmhnaidheach agus Cleachdadh Measgaichte**

1.4.1 **Designing Streets** sets out policy and guidance at national level and is mainly applicable to residential and other lightly trafficked streets. The emphasis is to increase the attractiveness of streets for pedestrians and cyclists, to increase the 'sense of place' and to reduce the dominance of the private car. In lightly trafficked streets there is an expectation that the design should be less determined by the requirements of motor vehicles and that the character of the environment should lead to a reduction in vehicle speeds thus improving the surroundings for other users. This should lead to a greater range and diversity of layouts and designs being acceptable and provide greater local character and choice.

1.4.2 The Council expects residential development proposals, where applicable, to be based generally on the principles of **Designing Streets**, which reflects government policy. For Development outwith the scope of Designing Streets, for example where high traffic volumes or speeds are anticipated or where development is accessed off existing roads, the requirements of this document (Roads and Transport Guidelines for New Developments) shall be applied. It is recommended that developers seek early discussion with the Council to agree the design parameters to be incorporated within new residential developments.

- 1.4.3 Whilst it is desirable to create new environments which are less dominated by the motor vehicle, the continuing role of the car and other motor vehicles must be fully recognised in development proposals with adequate provision made for parking, service vehicles and bus routes. Roads considered to have a distributor function and where higher levels of traffic are anticipated are not specifically covered in **Designing Streets** and shall be designed to take account of appropriate standards in accordance with the guidance in this document.
- 1.4.4 The Council acknowledges that appropriate design speeds, road geometry and applicable speed limits for proposed new roads will be influenced by adjacent development, traffic flows and their composition, together with movement and place considerations. Hence, this should result in more design-led solutions on an individual site-by-site basis rather than rigidly using fixed standards.
- 1.4.5 Mixed-use developments are encouraged, especially with a network of well-connected streets. This can result in local facilities being in close proximity to each other, such that sustainable modes of travel, especially walking, can be predominant within the area.

1.5 Development in the Countryside / Leasachadh air an Dùthaich

- 1.5.1 For the development of single houses and small clusters of up to four houses where there is no requirement for the construction of a new adopted road reference should be made to the **Access to Single Houses and Small Housing Developments**.
- 1.5.2 For larger proposals in the countryside requiring a new adopted road or an extension to an existing adopted road, developers will be expected to come forward with proposals which respect the rural character of the area. These will nevertheless be expected to cater safely for pedestrians, cyclists and vehicular traffic and be constructed to high standards in order to minimise maintenance over the design life of the proposed road.

CHAPTER 2 – PLANNING / CAIBIDEAL 2 – DEALBHADH

2.1 Planning Applications / Iarrtasan Dealbhaidh

2.1.1 General

2.1.1.1 Chapter 2 relates to the transport, flooding and drainage issues of a planning application that are considered by the Local Roads Authority as a Statutory Consultee and how the issues are dealt with.

2.1.1.2 Guidance on other planning aspects of a development proposal can be obtained from the Council's relevant Planning and Building Standards Office (Appendix 2).

2.1.1.3 Figure 2.1 shows a summary flowchart that provides a summary of the planning process. The role and input from the Council's Planning and Development Service and also TEC Services are illustrated. Planning and Development staff will lead the process.

2.1.1.4 For most planning applications, the Roads Authority will be consulted. Transport Scotland is consulted in relation to those applications that affect or are close to a Trunk Road and further advice is contained within **Development Management Guidance**, published by Transport Scotland. For applications affecting Trunk Roads, comments are also usually requested from the Council, as Local Roads Authority.

2.1.1.5 **A developer should note that the granting of planning permission does not place an obligation on the Council to either permit the construction of a new road or adopt a new road.**

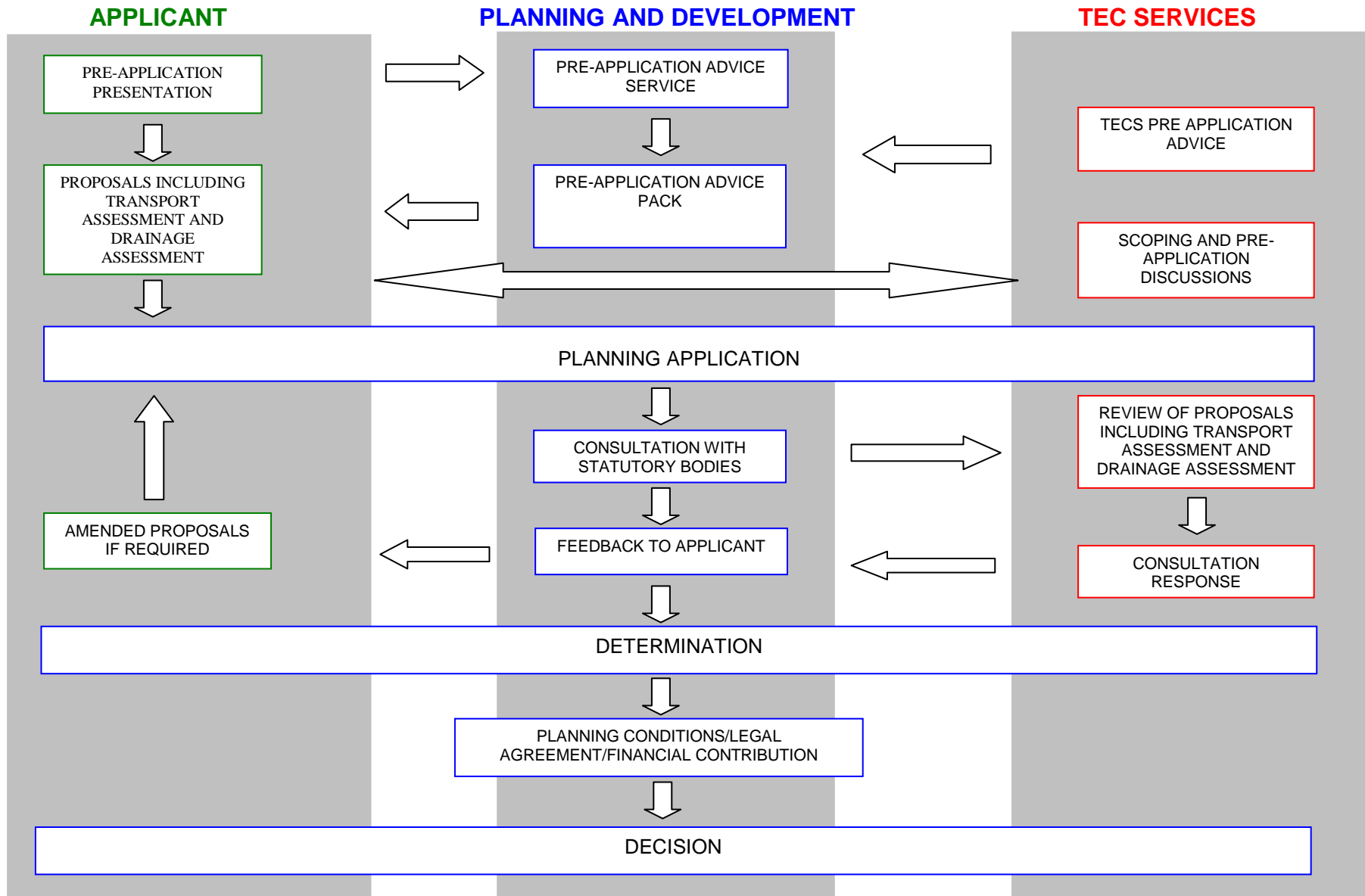

Figure 2.1 Planning Application Process – Summary Flowchart

2.1.2 ***Pre-application consultation and scoping***

2.1.2.1 Prior to submitting any planning application, it is strongly recommended that a developer initially consults the Council's Planning and Development Service at an early stage in the preparation of a development proposal. This is especially important for medium/large or sensitive proposals. The Council's Planning and Development Service shall be the main point of contact during the application process and will be able to discuss key issues and agree scoping requirements such as:-

- location;
- scale of development;
- access arrangements;
- layout;
- design; and
- mitigation measures.

2.1.2.2 For national and major developments, as defined within **Circular 5/2009 – Hierarchy of Developments**, pre-application consultation with the public is now a mandatory requirement and a Pre-Application Consultation (PAC) Report has to be submitted with the planning application.

2.1.2.3 Whilst there is no statutory basis for pre-application consultation with the Council, the Council does provide a pre-application advice service for major developments in which TECS participates in providing advice on transport, flooding and drainage. For smaller developments the developer is advised to contact the relevant TEC Services Office in circumstances where pre-application advice on transportation matters, including Road Construction Consent, would be beneficial. It should be noted that if no such pre-application discussions are held, this could result in the developer undertaking abortive work and incurring un-necessary expense.

2.1.2.4 During the pre-application stage, the developer may be advised to seek certain aspects of transportation advice from specialist sections of TEC Services, with regard to some particular aspect of the proposal, such as road structures, lighting or public transport.

2.1.2.5 For medium/large development proposals or those of a sensitive nature, there is likely to be a requirement for the developer to agree scoping requirements. Scoping seeks to agree what issues need to be considered, together with the type and detail of information that should be provided as supporting information for a subsequent planning application. Agreement of scoping requirements is important as it can significantly reduce the time taken to determine the application and help avoid un-necessary delay. Where there is a requirement for a Transport Assessment this should be subject to a scoping agreement.

2.1.3 **Masterplanning**

2.1.3.1 For large development proposals, particularly involving mixed land uses, the Council may require some form of master planning or planning brief to be undertaken by the developer. A planning brief or master plan can play an important role in the delivery of sustainable developments and communities, as it clearly sets out proposals for buildings, spaces, movement and land use, together with an implementation strategy. Masterplanning is intended to be a positive process that seeks to address the wide-ranging issues needing to be addressed in order to make places successful, in terms of planning policy.

2.1.4 **Making a Planning Application**

2.1.4.1 For all applications it is important to include all the relevant documentation to enable the application to be determined at the outset. Provision of full information with the application avoids the need for additional details to be requested and will reduce the possibility of delays arising during the process. The information in the following sections is given as a guide to the level of detail required as a standard minimum but as each site is different and is subject to different considerations and issues additional information may be required by the Council in individual circumstances. Applicants are advised to consult the Council to establish the level of detail required in any particular case.

2.1.4.2 Applications for single houses and small groups of houses where there is no requirement for a new adopted road are covered by the guidance document **Access to Single Houses and Small Housing Developments**. For developments in this category the following documents are required:

- a site location plan at a minimum scale of 1:10,000
- a proposed site plan at a minimum scale of 1:500 which shows existing public roads, the proposed site access arrangements with dimensioned bell mouth, service bay and visibility splays
- a completed **Private Access Checklist**

The above information is required for applications for both Planning in Principle and Full Planning.

2.1.4.3 For larger developments not covered by 2.2.2 above the requirements are given in the following sections:

2.1.4.4 For applications for **Planning in Principle** the level of detail required depends on the scale of development and the anticipated transport impacts. The minimum requirement for most developments is as follows;

- a site location plan at a minimum scale of 1:10,000,
- a proposed site plan at a minimum scale of 1:1,250 which identifies the site boundaries, existing public roads and footpaths, the proposed site access locations,

- dimensioned plans showing the details of the proposed accesses onto the public road including carriageway and footway widths, bell mouths and visibility splays. A scale of 1:500 is normally appropriate,
- plans showing details of any offsite mitigation proposed to the existing public roads, including but not confined to road widening, bus stops, pedestrians crossings, junction upgrades, traffic calming and the like,
- Form TA1 Transport Form or a Transport Assessment (TA). The requirement for a TA is to be agreed with the Council and will generally be in accordance with the guidance given below,
- an indicative internal layout may be submitted for illustrative purposes but is not binding on the developer (it should be noted that although the layout is not binding the quantum of development and hence the transport impact of the proposed development must be identified)
- a Drainage Statement or Drainage Impact Assessment (for more information and criteria refer to *Interim Supplementary Guidance: Flood Risk & Drainage Impact Assessment*)
- for sites which are at risk of flooding a Flood Risk Statement or Flood Risk Assessment is required (for more information and criteria refer to *Interim Supplementary Guidance: Flood Risk & Drainage Impact Assessment*)

2.1.4.5 For applications for **Matters Specified in Condition (MSC)** the minimum level of information required is as follows;

- general arrangement plans of roads and parking areas, dimensioned to show carriageway and footway widths, road centre-line levels, building ground floor levels, bellmouths, turning heads, parking bays/in curtilage parking, communal cycle storage, provision for refuse/recycling storage/collection, service strips, bus stops, pedestrian crossings, cut and embankment slopes, drainage and the like, and showing areas proposed for adoption,
- proposals for dealing with watercourses,
- details of a site specific nature as required by the MSC.
- any matters not fully covered at Planning in Principle stage as detailed in 2.2.3.1

2.1.4.6 For **Full Planning** applications the details required will include all the information included in 2.1.4.4 and 2.1.4.5 above.

Table 2.1 Summary of Planning Application Supporting Documentation.

√ denotes information required

| Typically the following Documents are required: | PLANNING IN PRINCIPLE | MATTERS SPECIFIED IN CONDITION | FULL PLANNING |
|---|--|---|---------------|
| Location plan: scale 1:10,000 | √ | √ | √ |
| Site plan showing access arrangements min scale: 1:1,250 | √ | √ | √ |
| Dimensioned plans showing details of accesses onto the public road including carriageway and footpath widths, bell mouths and visibility splays | √ | If full details have not been provided at PIP then further information will be required under MSC | √ |
| Details of proposed offsite mitigation including road widening, bus stops, ped. crossings, junction upgrades, traffic calming | √ | If full details have not been provided at PIP then further information will be required under MSC | √ |
| General arrangement layout plans of roads and parking areas dimensioned to show carriageway and footway widths, road centre-line levels, bellmouths, turning heads, parking bays/in-curtilage parking, communal cycle storage, provision for refuse storage/collection, service strips, bus stops, ped crossings, cut and embankment slopes, drainage, and the like and showing areas proposed for adoption | Indicative layouts normally required showing leading dimensions to confirm site viability and gradients on steep sites | √ | √ |
| Form TA1 or a Transport Assessment where applicable. | √ | If full details have not been provided at PIP then further information will be required under MSC | √ |
| Drainage Statement or Drainage Impact Assessment in accordance with <i>Interim Supplementary Guidance: Flood Risk & Drainage Impact Assessment</i> . | √ | If full details have not been provided at PIP then further information will be required under MSC | √ |
| Detailed proposals for dealing with watercourses where applicable. | Outline proposals required at PIP | √ | √ |
| Flood Risk Statement or Flood Risk Assessment | For requirements refer to <i>Interim Supplementary Guidance: Flood Risk & Drainage Impact Assessment</i> | | |
| Site specific requirements of the MSC | | √ | |

2.1.5 ***Transport Considerations to be addressed in Planning Applications***

2.1.5.1 A developer must anticipate any future extensions to the development proposal and, therefore, design all new roads and other facilities accordingly. Further extensions that seek to make use of existing access roads may not subsequently be acceptable unless specific provision has been made within the initial design proposals.

2.1.5.2 The main transportation considerations will be the accessibility of all modes of travel to and within the development, together with the adequacy of the proposals in respect of all relevant modes of transport including the effect of the development on the surrounding public roads. In respect of transportation issues, the Council would assess relevant items from the following list:-

General

- the appropriateness of the development and the location in transport planning terms;
- the extent to which the proposals comply with the local plan and local transport strategy and the transport implications of this;
- the characteristics of the adjacent road network, based on the volume, type and destinations of vehicular and pedestrian traffic using it;
- how travel patterns are likely to change in the foreseeable future;
- extent and type of any transport computer modelling required by the Council;
- the volume and type of vehicular traffic likely to be generated by the proposed development, together with its envisaged distribution and impact;
- the adequacy of the adjacent road network to accommodate development traffic and the need for any mitigation measures, such as proposals for road widening, junction improvements and traffic management improvements. In certain circumstances, where development forms part of a wider expansion, developers will be expected to contribute to wider schemes of works through a process of developer contributions;

Accessibility

- proposed access locations to the development for all modes of transport, including pedestrians, cyclists, public transport and other vehicles. Any restrictions on locations, junction types, sight distances, gradients, etc. The safety of the road network, including proximity of any schools (which could require the introduction of adjacent statutory speed limits with associated infrastructure and also Safer Routes to School measures), emergency access;
- likely desire lines and facilities for pedestrians and cyclists, including connections to adjacent networks;
- likely public transport demand and the need for possible alterations or extensions to existing services or new service provision, as well as the need for bus stops and their infrastructure requirements, together with access arrangements and links, including to railway stations;

- accessibility within the site for all relevant modes of transport;
- the location and detailed design of pedestrian and cycle routes and crossing facilities, including connections with existing external routes;

Design

- likely number and type of internal road(s) to be provided and number of units served by each;
- the various types of new roads to be provided, together with their layout design, vertical profile and junction arrangements, for different classes of development;
- the safety of the road network and any associated mitigation measures, including Road Safety Audit Stage 1 or 2 Reports, as required by the Council;
- the amount of parking provision, for vehicles and bicycles, together with their locations;
- provision of road lighting;
- details of servicing requirements;
- locations of services, both underground and overhead;
- outline design proposals for bridges and road structures;
- flooding and drainage requirements;

External to the site

- the location of existing or proposed commercial destinations and community facilities, such as shops and schools, relative to the development and how they are to be connected/integrated with it;
- the location and treatment of any particular problem area external to the site, including any implications that may require the acquisition of land;
- any specific provision required to address the impact of traffic noise;
- construction related issues (routing/timing/volume/size) and any problems or restrictions that may be anticipated;
- the known requirements of any other affected bodies, particularly in relation to transport issues.

2.1.5.3 The Council would expect many of the above issues to be covered within a Transport Statement or Transport Assessment, submitted as supporting information by the developer in accordance with 2.3 below.

2.1.5.4 As not all the issues would apply to a particular development, it is essential that the developer discusses the proposals with the Council, in order to agree which specific issues need to be addressed by supporting information. A developer should note that many of the issues may need to be considered for an application for “Planning Permission in Principle” and, therefore, they may have to undertake a significant amount of work to provide acceptable levels of information.

2.1.5.5 For some of the above items, a full design, in respect of carriageways, footways and footpaths, with widths, corner and curve radii, levels, contours and gradients details, would need to be provided. To assist with any assessment, it is desirable that **layout plans**, at a minimum scale of 1:500, are submitted with sufficient detail. The design aspects should be consistent with the recommendations set out in Chapter 5 of this document.

2.1.6 **Drainage and Flooding**

As well as transportation considerations, TEC Services is also responsible for the consideration of drainage and flooding issues. For a proposed development, this will include:-

- details of the arrangements for the collection and disposal of surface rain water, including an indication of Sustainable Urban Drainage measures to be employed and an assessment of any potential flooding arising from storms; and
- the capacity of the existing road surface drainage system, together with the developer's flood risk and/or outline drainage design, including a Drainage Statement where deemed necessary, together with any other known service requirements.

Further guidance on drainage is given in Chapter 5 and flooding is covered in Chapter 8.

2.2 **Transport Forms, Statements and Assessments / Dòighean, Aithrisean agus Measaidhean Còmhhdhalach**

2.2.1 ***Transport Form***

2.2.1.1 For all planning applications, except those for four or fewer houses, the Council will require the applicant to submit a completed TA1 Transport Form, as set out in Appendix 3, as one of the supporting planning application documents. It would be helpful if the Transport Form was made available during pre-application discussions as this will help identify and inform the need for a Transport Assessment.

2.2.2 ***Transport Statements***

2.2.2.1 For developments for which a full Transport Assessment is not required but which nevertheless have transport impacts, there will be a requirement to provide a short Transport Statement setting out how the proposed development intends to comply with the Council's transport objectives, such as accessibility and parking.

2.2.3 ***Transport Assessments***

2.2.3.1 For all developments with significant transport impacts a Transport Assessment (TA) is required. TAs are required for all developments exceeding the thresholds given below and in some cases will be required for smaller developments where the transport impacts are considered to be

critical or impact on sensitive locations of the transport network. The requirement for a TA should be discussed and agreed in advance with the Council.

2.2.3.2 The Council would normally expect a TA to be provided when a development meets or exceeds any of the following criteria:-

| USE | Scale of development above which a TA is required |
|-----------------------------------|--|
| Food retail | 1,000m ² Gross Floor Area |
| Non-food retail | 1,000m ² Gross Floor Area |
| Cinemas and conference facilities | 1,000m ² Gross Floor Area |
| Leisure facilities | 1,000m ² Gross Floor Area |
| Business | 2,500m ² Gross Floor Area |
| Industry | 5,000m ² Gross Floor Area |
| Distribution and warehousing | 10,000m ² Gross Floor Area |
| Hospitals & health facilities | 1,000m ² Gross Floor Area |
| Higher and further education | 2,500m ² Gross Floor Area |
| Stadia | 1,500 seats |
| Housing | 100 dwellings |

2.2.3.3 The TA should be prepared with reference to **Planning: Transport Assessment and Implementation: A Guide**. In addition, a Cycle Audit, as described in **Cycling by Design**, published by then Scottish Executive (now Scottish Government), in 2000, may also be required and this should comprise part of the TA (*A new version of Cycling by Design is due to be published*). The Council should be contacted for further guidance.

2.2.3.4 Where a Transport Assessment is required, it will be a material consideration in the assessment of the planning application.

2.2.3.5 Where a TA is required, it is recommended that the developer seek early discussions with the Council, to agree the scoping requirements. This is likely to be in the form of a Scoping Paper produced by the applicant and submitted for comment and agreement with the Council.

2.2.3.6 The TA must be a comprehensive and consistent review of all of the potential transport impacts arising from a proposed development. The document should clearly set out the developers assumptions and how conclusions and recommendations have been reached. The TA should provide a balanced view of the proposed development, considering both positive and negative impacts.

2.2.3.7 In general, the TA should address the potential accessibility of the proposed development by all modes of transport and the capacity/relevance/suitability of those modes to accommodate the trips generated by the development whilst, at the same time, seeking to reduce car dependency. The Council would expect a TA to cover the following topics:-

- Existing site and surrounding transport network
- Summary of development proposal

- How the development relates to the requirements and policies of the local development plan
- Accessibility of site by all modes of transport, target population and catchment area
- Pedestrians, cyclists, public transport, private cars and service vehicles
- Trip generation and distribution, relating to person trips
- Modal split and vehicle trip rates
- Social inclusion issues
- Impact of trips on the transport network including affected junctions and areas which may already be subject to congestion. Appropriate analysis and modelling techniques shall be employed including the use of the Council's strategic transport model where relevant.
- Details of on-site and off-site transport proposals
- Details of any required mitigation measures
- Parking provision
- Travel Plan framework
- Conclusions, and recommendations.

2.2.3.8 For developments having a transport impact across a wide area the assessment of the proposals using the Council's strategic transport model may be required. The requirement for this and the procedures to be employed should be discussed at an early date with the Council.

2.3 Travel Plans

2.3.1 A Travel Plan is a package of measures, tailored to the needs of individual sites, aimed at promoting sustainable travel within an organisation, development site or residential area, with an emphasis on reducing reliance on single car occupancy travel.

2.3.2 Travel Plans are tailored to the specific circumstances of a location and should reflect the nature and type of development. As a minimum, a Travel Plan should include:-

- A clear statement of targets and objectives;
- An assessment of existing transport infrastructure and facilities on site;
- An assessment of the travel needs that are, or will be, generated on site. This is achieved by answering five key questions – Who? Where? Why? When? and How?
- A programme of appropriate measures that will improve accessibility and promote sustainable travel options;
- A programme for the implementation of the Travel Plan, detailing the dates by which the various measures will be put in place;
- The identification of who is responsible for actions of the implementation plan;
- The identification of how required funding will be provided;
- A firm commitment to implement the measures identified; and
- Monitoring mechanisms to ascertain progress towards achieving targets.

Further guidance is provided in Appendix 4

2.3.3 Where a TA is required, it must include a Travel Plan Framework. Thereafter, a draft Travel Plan shall be submitted to the Council for approval prior to opening or occupation of the development. In certain circumstances, the Council may request a Travel Plan be prepared even if no TA is required.

2.4 Meeting the Needs of People with Disabilities / A' Coinneachadh ri Feumalachdan Dhaoine le Ciorraman

2.4.1 People with some form of disability account for almost 20% of the UK population and it is important, therefore, that new developments take account of the needs of people with disabilities and the **Disability Discrimination Act 2005** (DDA) makes it a legal requirement. To help meet the requirements of the DDA, there are numerous sources of guidance widely available, with "**Inclusive Mobility: A Guide to Best Practice on Access to Pedestrian and Transport Infrastructure**" (Department of Transport, 2002), and **Planning Advice Note 78 – Inclusive Design** (Scottish Government, 2006), being two relevant documents. Transport Scotland published "**Disability Discrimination Act – Good Practice Guide for Roads**" in October 2009, which is intended to be a Scottish equivalent of the Inclusive Mobility document and will be a mandatory requirement in meeting the needs of the DDA on Trunk Roads. However, much of its guidance and recommendations can equally apply to the local road network.

2.4.2 The **Disability Discrimination Act - Good Practice Guide for Roads** contains the requirements for inclusive design in the construction, operation and maintenance of Trunk Road infrastructure that can equally apply to new development roads. Inclusive design is an approach which aims to create environments which can be used by everyone, regardless of age or disability. The most common elements of the Guide have been incorporated throughout this document.

2.4.3 The above requirements are consistent with the **Town and Country Planning (Scotland) Act 1997** that now requires Design and Access Statements to be submitted as part of many planning applications. The Statements are to set out how the needs of people with disabilities are to be met and the Council would check these and need to be satisfied that such needs have been met, prior to granting approvals.

2.4.4 A key element of inclusive design and a requirement of the DDA is the involvement of disabled people. There may be a need, therefore, especially for large developments, in seeking the views of disability organisations, as part of the design process and the developer should consider this carefully.

2.4.5 Local Access Panels include disabled people with an interest in improving access to the built environment and can be useful groups to involve during the development of new roads. The Council can co-ordinate consultation.

CHAPTER 3 – ROAD CONSTRUCTION CONSENT AND TRAFFIC ORDERS / CAIBIDEAL 3 – AONTA TOGAIL RATHAID AGUS ÒRDUGHAN TRAFUAIG

3.1 Road Construction Consent Applications / Iarrtasan airson Aonta Togail Rathaid

3.1.1 General

3.1.1.1 In terms of Section 21 of **The Roads (Scotland) Act 1984**, any person, other than a Roads Authority, who wishes to construct a new road or extend an existing road must, before commencing construction, obtain Road Construction Consent.

3.1.1.2 Section 151 (1) of **The Roads (Scotland) Act 1984** states:-

““road” means any way (other than a waterway) over which there is a public right of passage (by whatever means) and includes the road’s verge,etc.”

3.1.1.3 It is an offence, under the terms of the Act, to commence the construction of a road prior to obtaining Road Construction Consent. Such Consent is granted by the Council, in its role as Local Roads Authority. Road construction works should normally be completed within a period of three years from the date Road Construction Consent is granted. Road construction works may only be undertaken while the Consent remains valid.

3.1.1.4 Road Construction Consent pro-formas are detailed in Appendix 5 and it would be acceptable to use copies of these pro-formas when making application. Otherwise forms can be obtained from the majority of the Council offices.

3.1.1.5 It is strongly recommended that the applicant seek early discussions with the Council, with regard to any prospectively adoptable roads proposed as part of a new development, prior to the application for Road Construction Consent. Such roads will influence the development proposals and they should be included as part of the planning application discussions from an early stage, so that road construction issues can be considered as integral aspects of the proposals rather than as a follow-up process. The Council will provide the applicant with contact details of specialist sections, such as Road Structures, Road Lighting and Waste Management, who may also have to be consulted. This consultation should, ideally, be undertaken during the planning application stage.

3.1.1.6 Road Construction Consent will only be granted where proposals for the layout and construction of roads, road structures, road drainage and lighting comply with the standards set out within this document or as amended in agreement with the Council and are part of planning consent granted by the Council. Ease of future maintenance requirements, in terms of layout and materials, will be a consideration in the assessment of the Road Construction Consent application. The Council’s expectation is that applicants will produce designs and finished construction to standards equal to those of road schemes commissioned by the Council.

3.1.1.7 Where a road structure, such as a bridge, culvert or retaining wall, is proposed as part of a development, that structure will require Approval in Principle, before the start of any detailed design (see Section 3.1.7). The applicant should, therefore, enter into early consultation with the Council. The type and complexity of any proposed road structure, including physical or loading alterations to existing structures, will influence the form of Design and Check Certificate to be submitted.

3.1.1.8 In relation to residential developments, **The Security for Private Road Works (Scotland) Regulations 1985**, as amended by **The Security for Private Road Works (Scotland) Amendment Regulations 1998**, require a developer to lodge a financial security with the Council prior to commencing house construction, in case the developer is subsequently unable to complete the prospectively adoptable roads. Further details are provided in Section 3.1.19.

3.1.1.9 For other types of development, the Council may require the developer to pay a financial contribution, lodge a financial bond or enter into a suitable legal agreement where road improvements outwith the development site are deemed necessary.

3.1.1.10 The granting of Road Construction Consent does not exempt the applicant from obtaining any other necessary permissions or consents, such as a Building Warrant or approvals for connection to a sewer or discharge into a watercourse. The applicant should also note that Road Construction Consent will not be granted until detailed planning consent is in place.

3.1.2 ***Private Access***

3.1.2.1 There is a significant distinction between a road and a private access, which a developer should be aware of.

3.1.2.2 A private access is defined as any way over which the public do not have a right of passage and is controlled by the owner(s).

3.1.3 ***Residential Developments***

3.1.3.1 The current policy of the Council is that four or fewer individual residential houses can usually be served by a private access and would not require Road Construction Consent, although the junction onto the public road must be designed and constructed to a standard approved by the Council. A developer must be aware that, in such circumstances, the private access will not be available for adoption and future occupiers must be made aware of this, as they would be liable for maintenance. If a developer intends to provide a layout that includes a private access, this should be clearly indicated during the planning application stage.

3.1.3.2 The private access must provide adequate turning facilities, to accommodate all types of vehicles likely to use it, including possible service vehicles, although the developer should be aware that refuse vehicles and winter maintenance vehicles acting for the Council, are generally not permitted to go on a non-public road. In addition, as stated above, a suitable junction with the

public road must also be provided and for that section of the junction within the existing public road boundary, approval of its design and materials would be required from the Council. Further information on this requirement within **Access to Single Houses and Small Housing Developments** may be relevant.

3.1.3.3 Exceptions to the “four house” rule, with more than four houses being served by a private access, may be considered by the Council where the developer agrees, as a condition of planning consent, to set up a formal management system for maintenance of the private access in perpetuity. However, if there is any intention that in the future the number of individual houses would be increased to more than four or the private access put forward for adoption, then this would only be acceptable to the Council as long as the private access was upgraded to adoptable road standards. This may involve widening of the access and, therefore, suitable land should be reserved and safeguarded to accommodate widening should there be any such further development intentions.

3.1.3.4 In addition, there may be occasions, particularly within the urban environment, where an existing public road is proposed to be extended in order to serve four or fewer new houses. In such cases, the Council would normally require the extended section of road to be adopted as public and, therefore, constructed to the appropriate standard.

3.1.4 ***Access for Other Developments***

3.1.4.1 An industrial development should be served by a road that requires Road Construction Consent. For other types of development, such as retail developments, private accesses may be acceptable. However, where provision is made for internal access by public transport vehicles, Road Construction Consent will normally be required for those internal roads over which these vehicles will travel.

3.1.5 ***Works on an Existing Public Road***

3.1.5.1 The **New Roads and Street Works Act 1991** gives Statutory Undertakers the right to work on a public road, subject to notification being given to the relevant Roads Authority. This right also applies to a person installing new plant to be adopted by a Statutory Undertaker or is working on behalf of a Statutory Undertaker. Such a person must make an application, in terms of the Act, and pay the relevant fee. It should also be noted that only an approved contractor can undertake such works on the public road.

3.1.5.2 Any other works on an existing public road will require permission from the Council, under the terms of Section 56 of the **Roads (Scotland) Act 1984**. The Council must be consulted before any such work is carried out on an existing public road, in order to agree and approve it. Standards and specifications shall be consistent with this document, unless agreed otherwise. For significant works, there is likely to be a requirement for the applicant to provide drawings, similar to those required for a Road Construction Consent.

3.1.5.3 Application forms for Section 56 Permission can be obtained from the Council and must be submitted prior to the work being undertaken. Details of current fees can be obtained from the Council.

3.1.5.4 In programming works on a public road, the applicant must take account of the notice periods required, in terms of the **Scottish Road Works Register**.

3.1.6 ***Application for Road Construction Consent***

3.1.6.1 An application for Road Construction Consent should be made on **Form RCC F1** (Appendix 5) and submitted at least three months prior to proposed commencement of construction. It is recommended that formal application is not submitted until the detailed layout has been agreed through the planning process. It is advisable, therefore, to hold pre-application discussions and consider lodging a draft submission.

3.1.6.2 For the formal application, Form RCC F1 should be accompanied by three paper copies of detailed plans, folded to A4 size, and one electronic copy of each plan (in a format agreed with the Council) together with other associated documents, which should provide the following information:-

(i) a location plan, preferably on an Ordnance Survey base, to a scale of 1:1250 or 1:2500, showing the proposed development layout and its associated road network, together with exact development site boundaries;

(ii) a layout plan of the road network, showing carriageway, footways, verges cycle tracks, footpaths, bridges, retaining walls, other structures, earthworks and other relevant detail, to a scale appropriate for showing the detail of the layout (1:500 minimum, 1:250 or 1:200 where pedestrian/vehicle shared surfaces are proposed). The plan shall show:-

- the proposed centre, building, kerb lines and footway edges (including the footway heel line where this differs from the building line), together with relevant widths and widening where appropriate;
- curve radii of road alignments and junctions;
- dimensioned visibility splays at road junctions and private accesses;
- forward visibility envelopes at bends and crests;
- traffic management measures;
- dimensioned vehicular access points to properties and driveway gradients;
- pedestrian crossing points at junctions and other locations, where dropped kerbs will be provided;
- cycle crossing points;

- the form (ie a sustainable urban drainage system) and location of the road surface water drainage system and its discharge points, together with design calculations and long term maintenance requirements;
- carriageway falls and the location of all road gullies, including their connections to sewers and/or the sustainable urban drainage system;
- the location and type of lighting columns and lanterns, wall mounted lighting units (if applicable), control pillars, underground cables, road crossing ducts and any other secondary lighting;
- the location of all underground and overhead (if any) services and ancillary apparatus;
- the full extent of all cut and fill slopes;
- the boundaries of any areas that it is intended will subsequently be offered for adoption or maintenance;
- the layout and details of proposed road markings, traffic signs, street name plates and traffic signals;
- the details of other items, such as grit bins, play park equipment, refuse bin storage and public transport infrastructure;
- landscaping layout and details, showing all locations within the proposed road boundary;
- existing and proposed ground level contours; and
- building ground floor levels.

(iii) longitudinal sections along carriageways, footpaths and cycle tracks, giving vertical alignment details, surface water drainage gradients and manhole locations;

(iv) a ground investigation report, including a Factual Report and corresponding Interpretative Report as deemed necessary, providing appropriate information, including the nature of the substrata below road formation level or to rock head, where bedrock is located at a depth of less than one metre below formation level;

(v) typical cross sections, through carriageways, footways, footpaths, cycle tracks and adoptable parking areas, detailing widths, crossfalls, construction depths of materials, kerb and edge details, verge details and typical details of gullies and gully connections, together with specific sections at critical locations and a copy of a Drainage Impact Assessment, if appropriate;

(vi) specification details;

(vii) an accurate cost estimate for the new roads and associated infrastructure, with information to be provided in a Bill of Quantities format agreed with the Council;

(viii) a copy of the "Full" or "Matters Specified in Conditions" planning permission;

(ix) a Road Safety Audit Stage 2 report, when required by the Roads Authority; and

(x) flood risk assessment report and/or a drainage impact assessment report, when required by the Roads Authority.

3.1.6.3 The construction details submitted must comply with these Guidelines and the Road Construction Consent application submission shall be signed by an experienced and competent person, who shall verify this.

3.1.6.4 It will be acceptable for draft versions of the documents listed in paragraph 3.1.6.2 to be submitted, for initial comment, in an approved electronic format previously discussed with the Council to confirm details of acceptable format types. However, the final copy of the Road Construction Consent application must be submitted in paper format, with three paper copies and one electronic copy of all plans. Paper copies are required for signature by the Council, as part of the approved Road Construction Consent.

3.1.6.5 The applicant should be aware an application for Road Construction Consent is subject to payment of an associated fee. Details of the current fee structure, based on the estimated cost of construction of the new roads and associated infrastructure, can be obtained from the Council. Prior to submission of the application, the cost estimate and details of the appropriate fee should be discussed and agreed with the Council. Further details are provided in Section 3.1.23.

3.1.7 **Road Structures**

3.1.7.1 Where proposals include new road structures (eg. bridges, culverts and retaining walls) or alterations to existing road structures, the proposals shall be submitted for acceptance in accordance with the Council's Technical Approval procedures. The stages include:-

- application for Approval in Principle
- submission of Design and Check Certificates, and
- submission of a Construction Compliance Certificate

by the applicant or the appointed Engineer. At each stage, submissions shall include appropriate preliminary or detailed drawings (including "as built").

3.1.7.2 The Council is the Technical Approval Authority (TAA) for road-related structural proposals. The management of the TAA function is by the Council's Chief Structural Engineer, from whom relevant forms can be obtained and to whom submissions should be made. The Chief Structural Engineer will advise Council colleagues on the acceptability of structural proposals, prior to the issuing of the Road Construction Consent.

3.1.7.3 The applicant or the Engineer should **make very early contact** with the TAA to discuss and agree design parameters and the Technical Approval process.

3.1.7.4 Should the need arise, after granting of the Road Construction Consent, for additions or amendments to structural proposals, the applicant or the Engineer shall revert to the TAA and have such proposals accepted by the Council before the start of construction of the additional or amended road structure.

3.1.8 **Drainage**

3.1.8.1 Drainage layouts and designs for only the road drainage must be approved by the Council. If the design includes both road surface water and private roof/curtilage drainage, then the system may be approved and adopted by Scottish Water if complying with their design standards. Before adopting the system, Scottish Water will normally require the developer to complete a schedule of drainage so the system can ultimately be included in a Section 7 Agreement (**Sewerage (Scotland) Act 1968**), between the Council and Scottish Water. This would only occur following road adoption. **Adoption proposals for drainage systems must be agreed and approved during the planning stage.**

3.1.8.2 In addition, all developments are required to ensure road drainage discharge is treated by a sustainable urban drainage system (SUDS), with the SUDS design agreed with the Council, Scottish Water and the Scottish Environment Protection Agency (SEPA). The RCC applicant shall provide written confirmation that Scottish Water and SEPA have agreed the proposed drainage layout, which must be considered during the planning application stage of the development process.

3.1.8.3 If the drainage layout needs to include any connections to a private drainage system, the applicant shall provide written confirmation that the appropriate proprietor and other relevant parties, such as SEPA, are in agreement with the proposal.

3.1.8.4 For drainage and SUDS, the developer should refer to various documents, including the **Sewers for Scotland 2** technical manual, produced by Scottish Water, various SUDS guidance documents, particularly those produced by SEPA and CIRIA and also the **SUDS for Roads** guidance manual produced by SCOTS (Society of Chief Officers of Transportation in Scotland).

3.1.9 **Road Safety Audits**

3.1.9.1 New roads, junctions and pedestrian/cyclist facilities, together with any required improvements to the external road network, may require to be audited for road safety. Such a requirement will normally be highlighted during the planning application process and be set out as a condition of any granted planning consent.

3.1.9.2 Where required by the Council, a Stage 2 Road Safety Audit shall be carried out in accordance with **HD19 Road Safety Audit**, as set out in the DMRB, and the report submitted as part of the Road Construction Consent application. In some circumstances, the Council may require the applicant to carry out a Stage 1 Audit initially.

3.1.9.3 For the majority of schemes, a Stage 3 Audit will also be required. For large developments, a Stage 4 Audit may also be required.

3.1.9.4 The applicant shall consider any recommendations of the Road Safety Audit reports, which cover all Stages of the process. The applicant shall be responsible for all fees, construction and any future remedial actions, arising from the various Audit Stage reports.

3.1.10 ***Responsibility for Design***

3.1.10.1 The granting of Road Construction Consent does not imply that the Council accepts any responsibility for the accuracy and suitability of the scheme design.

3.1.11 ***Soil Report***

3.1.11.1 At the time of application, the applicant shall provide a soil report, giving details of the California Bearing Ratio (CBR) test results of the sub-grade material. If any proposed road construction is to be less than 450mm in depth, the soil report shall include a certificate of non-frost susceptibility, in relation to the sub-grade. The soil report must also clarify the suitability of the underlying site material, in relation to the SUDS design.

3.1.12 ***Mineral/Geotechnical Report***

3.1.12.1 In geographical areas known to have been in-filled, have a history of mineral workings or other geotechnical issues, the Council may require the applicant to supply a mineral report together with supporting information on ground stability. In certain circumstances, the Council may require the applicant to submit a more detailed geotechnical report.

3.1.13 ***Docqueting of Plans***

3.1.13.1 All plans, detailed drawings, reports and specifications submitted with the Road Construction Consent application (including electronic versions) are to be docqueted as follows:-

“This is the plan/drawing/specification referred to in the application”

and are to be signed and dated by the applicant or the agent.

3.1.14 ***Notice to Affected Parties***

3.1.14.1 The applicant should note that, as part of the Road Construction Consent application, notice of the application must be intimated by the applicant to the following:-

- the owners of all land that would front, abut or be comprehended in the new road(s) or extension of existing road(s); and
- such other person, if any, as specified by the Local Roads Authority.

Notice shall be made on **Form RCC F2** and **Form RCC F3**, as appropriate. (Appendix 5).

3.1.15 ***Representations***

3.1.15.1 Any person to whom the Road Construction Consent application has been intimated, under the provision of Section 3.1.14 above, may, within 28 days of the date of intimation, make written representations to the Council. Any such representations will be considered by the Council before any decision is taken in relation to granting Road Construction Consent or not.

3.1.15.2 The Council shall inform any person making representation what decision it has taken, with regard to that representation. The applicant should be aware that the consideration of representations could delay consideration of the Road Construction Consent application.

3.1.16 ***Hearing of Application***

3.1.16.1 Should the Council consider it intends to either (a) grant Road Construction Consent but subject to special conditions or (b) refuse the application, the applicant will be given the opportunity to be heard, prior to a final decision being made.

3.1.17 ***Duration of Road Construction Consent***

3.1.17.1 A standard condition of the Road Construction Consent will be that the construction shall be completed within a period of three years from the date on which the Consent was granted.

3.1.17.2 The Council may subsequently extend this period, provided the applicant submits a written request for an extension of time, explaining why it is required. Any approved extension of time will only be valid if provided in writing by the Council and in normal circumstances, only one request for an extension of time will be accepted. In the absence of any request for an extension of time, a new application for Road Construction Consent must be made if the three year period lapses.

3.1.18 ***Amendments to Road Construction Consent***

3.1.18.1 Should the applicant subsequently wish to amend any aspect of the granted Road Construction Consent, prior written approval must be obtained from the Roads Authority, which shall not be unreasonably withheld. Three paper copies and one electronic copy of drawings, relating to the changes, shall be submitted for approval.

3.1.18.2 The applicant should note that any requested major change to the granted Road Construction Consent may result in the requirement for a new application to be submitted.

3.1.19 **Road Bond**

3.1.19.1 In accordance with Section 17 of **The Roads (Scotland) Act 1984** and **The Security for Private Road Works (Scotland) Regulations 1985**, as amended by **The Security for Private Road Works (Scotland) Amendment Regulations 1998**, for a residential development, a developer must lodge a security, in the form of a road bond or deposit, in favour of the Roads Authority, to cover the cost of providing the roads to the standard set out in the Road Construction Consent. The road bond is intended to protect prospective house purchasers from having to arrange completion of roads to adoptable standards, in the event that the developer is unable to do so. The security must be lodged prior to commencement of any building works.

3.1.19.2 The applicant should note that the Council may require some form of financial security to be provided in relation to any prospectively adoptable road associated with an industrial estate development or where significant improvements to the external public road network are being undertaken by a private party, in association with a commercial development. This would apply to those improvements established as conditions of planning consent or included within an associated legal agreement, including the exchange of letters between the developer and the Council.

3.1.20 **Right of Appeal**

3.1.20.1 An applicant for Road Construction Consent may, within 28 days of the date of intimation of a decision of the Council to either (a) refuse the application or (b) grant the Road Construction Consent subject to special conditions, other than the three-year time period, appeal to Scottish Ministers.

3.1.21 **Offences**

3.1.21.1 In relation to the construction of new roads, under the terms of Section 22 of the **Roads (Scotland) Act 1984**, any person, other than a Roads Authority, who:-

- constructs a new road or an extension of an existing public road without Road Construction Consent; or
- contravenes or fails to comply with the terms of a granted Road Construction Consent.

commits an offence, which is subject to trial, either summarily or on indictment.

3.1.21.2 Where a condition imposed by a Road Construction Consent has been contravened or not complied with, the Council can, by serving notice on the person holding the Consent, require that person to bring the new road into conformity with the Road Construction Consent, within such a reasonable period as shall be specified in the notice.

3.1.22 **Powers of the Local Roads Authority**

3.1.22.1 Under Section 23 of the **Roads (Scotland) Act 1984**, the Council, in its role as Local Roads Authority, has the powers to stop up or temporarily close any new road that another person has constructed (a) without Road Construction Consent or (b) in contravention of or non-compliance with a condition imposed by a granted Road Construction Consent.

3.1.22.2 Stopping up or temporary closure may take place whether or not any proceedings are pending, under Section 22 of the **Roads (Scotland) Act 1984**, but shall be ended if in any subsequent proceedings, it is found that:-

- in a case where the stopping up or closure took place on the basis there was no Road Construction Consent, but there was such Consent; or
- in any other case, there was no contravention of or failure to comply with the Road Construction Consent condition to which the proceedings relate.

3.1.23 **Inspection Fee Charges**

3.1.23.1 Under the terms of Section 140(6) of the **Roads (Scotland) Act 1984**, the Council is entitled to recover expenses from the person to whom Road Construction Consent or authorisation has been granted. There are costs related to supervising and inspecting the Road Construction Consent works. It is reasonable that these costs should be borne by those parties wishing to construct a new road(s) or extension(s) of any existing road.

3.1.23.2 The Council currently applies a Schedule of Charges, which is intended to reflect the actual cost of carrying out the supervision and inspection duties. The Schedule is based on the estimated cost of construction, which shall be agreed with the Council. Prior to submitting the Road Construction Consent application, the applicant should contact the Council to confirm the appropriate fee, as the Schedule of Charges is liable to change.

3.1.23.3 The Council's current Schedule of Charges can be viewed and downloaded from the Council's website:- <http://www.highland.gov.uk/NR/rdonlyres/57CFB752-0C4D-4CF8-ADE6-7B840223CCC2/0/NewRoadsFunctionChargesV25April2013.pdf>

3.2 **Inspection Procedures during Construction / Modhan Sgrùdaidh rè Togail**

3.2.1 **Notice of Commencement**

3.2.1.1 At least two weeks' prior notice must be given, in writing, to the Council's Area Roads Manager before commencement of construction works. Names and contact details of those responsible persons, who can be contacted with regard to the works, shall also be provided, including an emergency contact. The Council will advise the developer of the name and contact details of the person who will act as the Council's Representative.

3.2.1.2 In order that progress on a new development may be assessed, a programme of proposed construction should be provided, in writing, giving information on the following categories:-

- all work within the area of carriageway construction, including drainage and sewer works, together with any service cross-connection ducts;
- carriageway construction, including formation preparation, sub-base, kerbing, gullies and binder course. It would be expected that carriageway construction courses would be suitable for use by construction plant and vehicles;
- building construction and installation of statutory utility services; and
- installation of street lighting, carriageway surface course, footway construction, traffic signals, road signage and markings.

3.2.1.3 In addition, if requested by the Council, a copy of the Construction Phase Health and Safety Plan shall be provided.

3.2.2 ***Inspection and Testing***

3.2.2.1 During the period of construction, the Council's Representative must be permitted access to the site, in order to check that the works are being undertaken in conformity with the Road Construction Consent.

3.2.2.2 The developer and/or the main contractor shall provide every facility to enable the Council's Representative the opportunity to examine the works being undertaken and materials being used. However, the developer shall remain responsible for ensuring the required standards are met.

3.2.2.3 In certain circumstances, the Council's Representative may require samples of various materials being used, together with details of their source or manufacture, so further testing can be carried out. Such samples shall be provided at no cost, with the developer also required to pay for the cost of any testing. The developer will also be responsible for providing test certificates for all materials used on site, when requested by the Council's Representative.

3.2.3 ***Notice of Operations***

3.2.3.1 The developer or the main contractor must give the Council's Representative a minimum of five working days written notice, which shall exclude weekends and public holidays, with regard to the following operations:-

- completion and approval of formation;
- approval of foundation level;
- commencement of different layers to the carriageways, footways, footpaths and cycle tracks;
- each concrete pour (including blinding) and commencement of steel fixing, where reinforced concrete is used;

- drainage systems and runs, especially where they are to be subsequently adopted by the Council;
- striking of formwork;
- bridgework waterproofing and expansion joints; and
- setting out road lighting and traffic signal plant positions, backfilling of cable trenches, painting of lighting columns, commencement of electrical works, testing and commissioning.

3.2.3.2 These are minimum requirements and, in certain cases, the developer or the contractor may be required to notify the Council's Representative of any other construction stage.

3.2.3.3 Failure to provide the minimum notice period may result in the Council's Representative instructing the works be re-opened, in order to permit inspection, with all associated costs being at the developer's expense. This also applies if the developer's/contractor's programme subsequently changes, unless a shorter notice period is agreed with the Council's Representative.

3.2.4 ***Substantial Completion of Works Inspection***

3.2.4.1 Towards completion of any development that includes new roads, the developer shall when required, undertake a camera survey of the prospectively adoptable drainage to confirm its acceptability to the Council.

3.2.4.2 Thereafter, a request should be made to the Council's Representative to have a "Substantial Completion of Works" inspection carried out. As a result of this inspection, either a Certificate of Substantial Completion will be issued or a list of any remedial work deemed necessary to bring the road(s) up to the Road Construction Consent standards will be prepared by the Council's Representative and provided to the developer, in writing, for implementation. Following the satisfactory completion of any required remedial work, an application may be made for the Substantial Completion of Works certificate.

3.2.4.3 For those developments where the Council requires a Stage 3 Road Safety Audit to be carried out, this should be undertaken and the report submitted prior to the Substantial Completion of Works inspection being requested.

3.2.5 **Reduction of Road Bond**

3.2.5.1 At pre-determined stages in the construction works, as specified in **The Security for Private Road Works (Scotland) Regulations 1985** and **The Security for Private Road Works (Scotland) Amendment Regulations 1998**, partial release of the Road Bond is permitted. Other appropriate stages may be agreed with the Council's Representative.

3.2.6 **Construction (Design and Management) Regulations 2007**

3.2.6.1 The developer is reminded of his responsibility under the terms of the **Construction (Design and Management) Regulations 2007** (CDM). The developer should be satisfied that he has appointed a CDM Co-ordinator, Designer and Principal Contractor, as required by the Regulations. The Council may request details of the appointed CDM Co-ordinator.

3.2.6.2 As mentioned in paragraph 3.2.1.3, if requested by the Council, a copy of the Construction Phase Health and Safety Plan shall be provided, prior to any construction works commencing.

3.2.6.3 On completion of the works, a copy of the Health and Safety File or that section relating to the prospectively public roads and associated infrastructure must be delivered to the Council.

3.3 **Adoption of Development Roads, Footways, Cycle Tracks and Footpaths / Gabhail Thairis Leasachaidhean Ùra a thaobh Rathaidean, Slighean-coise, Slighean-baidhsagail agus Ceuman-coise**

3.3.1 **Policy**

3.3.1.1 In terms of Section 16 of the **Roads (Scotland) Act 1984**, the Council will consider for adoption, ie add to its List of Public Roads, any new road the developer makes application for and which the public have the right to use. The new road shall have been designed and constructed to the standard approved by the Council, which shall normally be that set down in the Road Construction Consent. A new road will include associated footways, cycle tracks and verges.

3.3.1.2 New roads, footways, cycle tracks or parking areas put forward for adoption must be connected to an existing adopted public road, footway or cycle track, at the developer's expense.

3.3.2 **Phased Adoption**

3.3.2.1 To avoid possible long delays between the construction and adoption of new roads, the developer should programme the construction stage in a suitable manner such that adoption can be phased as sections of new roads are completed. However, phased adoption will only be considered subject to the following conditions:-

- carriageways, footways, verges, cycle tracks, road lighting and traffic signals will not be adopted separately;

- incomplete lengths of road between junctions or incomplete culs-de-sac will not be adopted;
- sections of roads submitted for adoption must form a continuous system with existing public roads; and
- the new roads must be serving a public need.

3.3.2.2 Where new roads are constructed and adopted in phases, temporary turning head facilities, designed in accordance with these guidelines, shall be provided. In addition, if the surface course is to be left off for any significant period (more than two months), then carriageway ironwork, especially road gullies, shall be set at binder course level initially then subsequently re-set to finished road levels.

3.3.3 **Verges**

3.3.3.1 Verges will only be considered for adoption where they form an integral part of the road and footway layout and accommodate public utility services. Verges should not be unduly extensive and the form of landscaping should seek to minimise expensive future maintenance, but recognising a desire to provide an attractive environment. Where prospectively adoptable verges are contiguous with private gardens, special attention will be required to ensure that the property owners are fully aware of the future rights of Statutory Undertakers and the Council to enter these verges. In such cases, the boundary between the garden and the verge should be permanently delineated with edging kerbs or similar or as agreed with the Council.

3.3.3.2 In general, the Council may expect visibility splays at the junctions of public roads to form part of the public road and, therefore, be put forward for adoption. In such circumstances, there must be a permanent delineation along the boundary of the visibility verge and the adjoining property or land.

3.3.4 **Footpaths and Shared Footpaths/Cycle Tracks**

3.3.4.1 Remote new footpaths or shared footpaths/cycle tracks will only be considered for adoption where they provide significant pedestrian links connecting houses, schools, shops, public leisure and entertainment facilities or where they form part of the cycle network or link between two public roads. In all other cases, unless agreed otherwise with the Council, future maintenance would be the responsibility of the developer. Footpaths and shared footpaths/cycle tracks should be constructed in accordance with the associated Road Construction Consent.

3.3.5 **Parking Areas**

3.3.5.1 Off-road parking areas associated with new development and redevelopment, such as residents' or staff parking, will not normally be considered for adoption, except in certain circumstances where they can meet a general public parking need. Areas of private parking must be subject to suitable private maintenance agreements, with responsibility remaining with the proprietors or

factors in the case of private housing, a Housing Association in the case of community housing, or the owners of any other development that has such parking.

3.3.5.2 Those areas forming visitors' parking spaces or service bays that are contiguous with the road and are clearly not for the sole or regular use of any specific dwelling, group of dwellings or other building will be considered for adoption. These spaces must allow for unrestricted use by the general public.

3.3.5.3 Where service bays or areas associated with industrial or commercial developments are contiguous with the public road, agreement must be reached with the Council as to whether they are to be adopted or not. There must be clear markings delineating private areas.

3.3.6 ***Adoption of Road Lighting***

3.3.6.1 Road lighting systems on those new roads, footways, verges, cycle tracks and footpaths that are prospectively adoptable will be taken over by the Council for future maintenance provided that they have been installed in accordance with the Road Construction Consent and to the satisfaction of the Council's local Area Lighting Engineer. In terms of street lighting, details of approved materials and the detailed adoption process for lighting are contained in the Lighting Section's document "**The Specification for the Lighting of Roads in Housing and Developments**" and the developer is recommended to obtain a copy from the Council's Lighting Engineer.

3.3.6.2 The developer or the contractor shall liaise with the local Area Lighting Engineer, with regard to lighting design, construction and testing and shall provide copies of test certificates, confirming that the electrical works have been installed in accordance with the required standards.

3.3.6.3 Until such time as the road lighting is adopted by the Council, the developer will remain responsible for the operation of the lighting system and also for all charges, including the electricity supply.

3.3.7 ***Adoption of Traffic Signals and Signs***

3.3.7.1 Traffic signals and signs, related to the development proposals, on prospective public roads will be taken over by the Council for future maintenance, provided they have been installed in accordance with the Road Construction Consent and to the satisfaction of the Council's Representative. Traffic signals must have been commissioned, tested and appropriate phases set before the Council will adopt them. For those signs requiring an electrical supply, copies of electrical test certificates will be required.

3.3.7.2 It is the Council's policy that all regulatory signs shall be installed prior to occupation of the first property served by a particular road, to which the signs relate. However, the Council's Representative may agree to the use of temporary signs, in certain circumstances.

3.3.7.3 The naming of new streets should be undertaken at an early stage, in conjunction with the Council's Ward Manager and Planning Service and comply with relevant Council policies.

3.3.7.4 The developer should note that the erection of private signs within the public road boundary or attached to street furniture requires Council approval. The Roads Authority has the powers to remove such private signs, with associated costs of doing so chargeable to the person responsible for their erection.

3.3.8 **Road Structures Agreements**

3.3.8.1 For those Road Construction Consents that involve a road(s) being supported by a bridge, the Council may require the developer to enter into an agreement with it, in terms of Section 79(1)(c) of the **Roads (Scotland) Act 1984**, whereby the bridge will heritably vest with the Council. Any other road structure, deemed essential, may also require such an agreement, to allow those structures and solums to vest with the Council. The developer should note that where a bridge or other road structure has not been acquired by the Council, the Council will only be responsible for maintenance of the road and footway surfaces.

3.3.8.2 Where land surrounding the road structure is not passed to the Council, there will be a requirement to ensure the Council is provided with a Grant of Servitude to allow access for future maintenance.

3.4 **Application for Adoption of New Roads and Footpaths / Iarrtas airson Gabhail Thairis Rathaidean is Cheuman-coise Ùra**

3.4.1 **Application for Adoption**

3.4.1.1 Following the issue of a Certificate of Substantial Completion, as described in Section 3.2.4, the developer shall undertake a 12-month maintenance period of the prospectively public road, with the developer being responsible for all maintenance issues, except winter gritting and snow clearing operations where agreed with the Council.

3.4.1.2 If any premises are occupied prior to adoption of the new road(s) the Council may agree to undertake winter maintenance, including gritting and snow clearing, when deemed necessary. For those roads constructed to binder course level or having wearing course but without a Certificate of Substantial Completion, winter maintenance would be undertaken on a chargeable basis. If a Certificate of Substantial Completion has been issued, there would normally be no charge for those sections of roads to which the Certificate applied. However, the developer should be aware that it is the Council's current practice that its refuse vehicles will only collect waste from an adopted road and, therefore, interim arrangements would have to be discussed and agreed with the Council, until such time as the development road(s) became public.

3.4.1.3 On successful completion of the 12-month maintenance period, a formal application for the adoption of the new road can be submitted by the person to whom the Road Construction

Consent was granted. Only those associated footpaths, cycle tracks and shared facilities previously agreed with the Council as prospectively adoptable will be adopted.

3.4.1.4 The application shall be accompanied by copies of all “as built” drawings, similar to those submitted as part of the original application for Road Construction Consent. These drawings are to be submitted as two sets of paper copies and one electronic copy in an agreed CAD format. All roads, footways, verges, cycle tracks, footpaths, shared footpaths/cycle tracks and structures offered for adoption shall be shown in colour, with ownership of areas also coloured and noted.

3.4.1.5 In addition, the developer shall arrange for a paper and electronic copy of the Health and Safety File, as required under the **Construction (Design and Management) Regulations 2007**, to be provided, together with a Construction Compliance Statement, as per Appendix 6. All submissions must be signed by an appropriate competent person with Professional Indemnity Insurance, who shall verify that all works have been constructed, in accordance with the Road Construction Consent, including items such as levels and materials.

3.4.2 ***Adoption Inspection***

3.4.2.1 Upon receipt of the application for adoption, the Council’s Representative shall arrange for an adoption inspection to be undertaken, to ensure that the road is suitable for adoption. If there are any defects, these shall be agreed between the developer and the Council and rectified by the developer.

3.4.3 ***Addition to List of Public Roads***

3.4.3.1 Following a satisfactory adoption inspection or following the correction of any defects, to the satisfaction of the Council, the road will be added to the Council’s List of Public Roads.

3.4.4 ***Release of Road Bond***

3.4.4.1 Following a satisfactory adoption inspection, the developer can make a written application for the remaining security or Road Bond to be released. This would be released upon receipt of the Health and Safety File, which shall include “as-built” drawings.

3.5 **Making Up and Adoption of Private Road / Dèanamh Suas is Gabhail Thairis Rathad Priobhaideach**

3.5.1 In certain circumstances, the owners of a private road may wish to consider having it adopted by the Council for the purpose of future maintenance. Guidance is set out in the relevant Council policy document, which can be viewed and downloaded from the Council website:- <http://www.highland.gov.uk/NR/rdonlyres/CB64BEB0-31E9-4977-9BF9-3B45B22F9BE5/0/unadopt.pdf> .

3.5.2 The owner should undertake discussions with the Council and a joint site inspection of the private road agreed and undertaken. The site inspection would establish the existing condition of the

private road and Council could provide an initial indication of the extent of any works required to bring the road up to the standards required by the Council. These standards relate to layout design, road drainage, street lighting, carriageway and footway construction and signage.

- 3.5.3 Following the site inspection, if the owners and the required proportion of frontagers decide to proceed with the possible adoption, they shall arrange for a detailed design to be undertaken, which shall comply with guidelines and standards within this document or as agreed with the Council. The owners shall follow the Road Construction Consent procedures, as described earlier in this Chapter and submit appropriate drawings and agreed supporting information. The owners also need to demonstrate that, where applicable, the agreement and approval of affected frontagers have been obtained.
- 3.5.4 Once the Council has granted approval for the proposed works, the owners shall undertake all necessary works, at no expense to the Council. Upon completion of said works, to the satisfaction of the Council's Representative, and following a 12-month usage period, the Council would then assess if the private road was suitable for adoption as a public road or if it required any remedial work before adopting it.

3.6 Traffic Orders / Òrdughan Traftaig

3.6.1 *Permanent Closures and Alterations to Public Roads*

- 3.6.1.1 When a developer wishes to close, divert, raise, lower or otherwise alter a length of existing public road, including the conversion of access rights of an existing public road, a formal application or request must be made to the Council, in terms of its powers under the **Roads (Scotland) Act 1984**.
- 3.6.1.2 An application or request to alter an existing public road should be submitted as soon as detailed planning permission has been granted, although it is recommended that the developer undertake prior consultation with the Council and also the Emergency Services, Statutory Undertakers and any other persons or bodies with an interest in the proposed alteration, in order to check its feasibility.
- 3.6.1.3 The developer should note if a Traffic Regulation Order (TRO) is needed, as part of the proposal, the period required for processing each TRO can be twelve months or longer, depending on factors such as whether or not objections to the proposal are received, the nature of the objections, the number and complexity of proposed TROs already waiting to be processed and the powers or not of the Council to deal with certain objections. A developer should take such factors into account, when preparing construction programmes or considering contractual obligations. Further information on TROs is given in Section 3.6.2.
- 3.6.1.4 In the case of a development yet to receive planning permission, an alternative procedure for the stopping up or diversion of a public road may be carried out in terms of the **Town and Country**

Planning (Scotland) Act 1997. However, the processing time is likely to take at least 12 months and, potentially, significantly longer.

3.6.2 **Traffic Regulation Orders**

3.6.2.1 Traffic management and parking requires to be regulated by various statutory orders, usually referred to as Traffic Regulation Orders (TROs). Such orders include:-

- those required for speed limits;
- those regulating on-street and off-street parking and also imposing parking charges;
- disabled persons' parking places, both on-street and off-street;
- stopping up former roads and footpaths that have been superseded by new roads; and
- stopping up occasioned by new developments.

3.6.2.2 Temporary TROs are also required for formal purposes, such as road works, utility and infrastructure improvements and can be necessary to aid the construction of new development.

3.6.2.3 There will be occasions when a new development requires an associated TRO, whether it is on a permanent or temporary basis. TROs relating to Trunk Roads are dealt with by Transport Scotland. For non-Trunk Roads within the Highlands, only the Council has the authority to promote TROs.

3.6.2.4 The promotion of a permanent TRO involves extensive discussion and consultation that leads to statutory procedures, requiring considerable staff time. It is very important, therefore, that a developer commence early discussions with the Council when a TRO is likely to be required. It is also important that correct information and details are provided, in order to help the process. However, a developer should be aware that the TRO process is subject to potential objections and, therefore, TROs may be lengthy to complete.

3.6.2.5 The Council's authority to implement most TROs is delegated to certain Council officials. When promoting a TRO, officials will follow procedures currently governed by **The Local Authorities' Traffic Order (Procedure) (Scotland) Regulations 1999 (LA Order Procedure)**, as amended.

3.6.2.6 Developers should be aware of the general TRO processes, as set out in the TEC Services' document "**Permanent Road Traffic Orders**", of which a current copy can be obtained from the Council:-

1. Initial preparation of proposals – it is important these are as accurate and final as possible and will be influenced by scheme design;
2. An initial consultation undertaken with a number of statutory consultees and other relevant interest groups – indication of how proposals will impact on community (it should be noted this differs slightly from the LA Order Procedure);

3. Assuming these initial consultees are content with the proposals, the Council will draft the formal Order;
4. Consideration is given to the extent of consultation and if it needs to be wider than is statutorily required;
5. Draft Order is advertised in a relevant newspaper. Street-bills are usually put up on or adjacent to the site. Initial consultees receive formal notice;
6. TRO objection period is normally 21 days, with 28 days required for speed limit TROs;
7. Any interested party can submit comments or an objection. Officials will seek to resolve objections, through discussions and provision of further explanation;
8. Where an objection cannot be resolved, details will be reported to Council Committee for a decision;
9. Some objections cannot be considered by Council Committee and may need to be assessed by an independent reporter, appointed by the Scottish Government;
10. If a decision is made that allows a TRO to proceed, a Notice is published in a relevant newspaper. The TRO only becomes effective when all associated signs and markings have been put in place;
11. The relevant Community Council shall be given written notification of publication of the TRO. In addition, all consultees are usually informed; and
12. Works associated with a TRO should normally be complete within two years from date of first publication, unless an extension is granted by the Scottish Government. Failure to meet this timescale can result in the whole process having to be repeated.

3.6.2.7 From the above, it can be seen that the promotion of a TRO can be a lengthy process. A TRO with no changes from its initial draft could be in place within 6 months. A TRO with objections that can be resolved with mitigating measures can take 9-12 months. However, a TRO that requires to be considered by an independent reporter could take 18-24 months. It should be noted that these timescales depend on available staff resources and the level of priority placed on the TRO. A developer needs to be fully aware of these timescales and factor them into the overall development programme.

3.6.2.8 The majority of TROs are promoted under the **Road Traffic Regulation Act 1984** or the **Roads (Scotland) Act 1984** legislation. However, as mentioned in Paragraph 3.6.1.4, the stopping up or diversion of a public road, in relation to a new development, may be carried out using legislation within the **Town and Country Planning (Scotland) Act 1997**.

3.6.2.9 Where a TRO is deemed necessary, as part of a new development, the Council will normally expect the developer to pay for the costs associated with the promotion of the TROs. These costs will include reasonable staff costs and advertisement charges.

SECTION 2 – STANDARDS AND GUIDELINES **/ EARRANN 2 – INBHEAN AGUS STUIRIDHEAN**

Section 2 of the Roads and Transport Guidelines for New Development document sets out the Council's current standards and guidance to assist the design of new road layouts, together with their associated services and facilities, to the standards required by the Council, if the road is to be adopted as public.

The section starts with establishing an appropriate layout, in terms of the intended road type, then provides guidance and requirements on various aspects of detailed design, including parking levels. Guidance on construction details and material standards is also provided.

For lightly trafficked residential streets, reference must be made to the Scottish Government's **Designing Streets** document, providing design parameters and guidance, which must be taken into account in the design of new or improved streets that serve residential areas.

Section 2 includes the following:-

- | | |
|-----------|------------------------------------|
| Chapter 4 | Road Network |
| Chapter 5 | Design Objectives and Requirements |
| Chapter 6 | Parking |
| Chapter 7 | Construction Materials Standards |

CHAPTER 4 – ROAD NETWORK / CAIBIDEAL 4 – LÌONRA RATHAIDEAN

4.1 Introduction / Ro-ràdh

4.1 Introduction

4.1.1 The Council currently maintains over 6,700km of local public roads throughout the Highland Area and there is a wide range of road types, from urban dual carriageways to rural single track accesses. Many of these roads, especially within rural locations, are “life line” routes, often providing the only means of access to a particular settlement. Given the diversity of the Highlands, there is also a wide range of different types of new roads constructed as part of new developments. It should be remembered that the road network is for all types of user and not just the private car.

4.1.2 The design of road layouts is a complex process, due to the number of considerations that need to be taken into account. However, for new development roads, the developer needs to ensure his design takes account of:-

- Safety
- Existing conditions – road types, traffic and transport modes
- Integration with existing network
- Accessibility within the development site
- Consideration of all modes of transport – pedestrians, cyclists, public transport and private vehicles, giving appropriate levels of priority
- Servicing requirements
- Environment and amenity

4.1.3 It is not the intention of this document to dictate the exact road layout that must be provided by a developer but there is a requirement to take account of certain standards and recommendations, together with policy and good practice guidance set out in other related documents, in order to produce a layout that fully integrates with the surrounding road network and adjacent areas. It is essential that the road layout is not considered as a separate entity but as a significant part of the overall design proposals for the whole development.

4.1.4 The Council acknowledges there are many existing roads within rural areas that do not comply with the guidance set out within this document. However, there are historical reasons for this situation and, wherever possible, new development roads should be designed to comply with these current guidelines.

4.1.5 Speed tends to be a primary cause of many road accidents and, therefore, a reduction in speed can reduce the number of accidents occurring, as well as reducing the severity of any resulting casualties. A new road layout should, therefore, seek a design that ensures vehicle speeds are

restricted to the appropriate level. For example, roads where there are high levels of pedestrian or cyclist activity should be designed to:-

- (a) minimise potential conflict between pedestrians/cyclists and motorised vehicles and
- (b) reduce the speed of vehicles, in order to address road safety issues. In some circumstances shared surface areas may be acceptable.

4.1.6 Whilst road designs should generally seek to restrict the speed of private vehicles, there may often be the conflicting desire to maintain speeds for public transport vehicles, in order to ensure their journey times remain attractive to users as an alternative to the car.

4.2 Road Types / Seòrsaichean Rathaid

4.2.1 General

4.2.1.1 The road network fulfils a number of functions, ranging from the strategic movement of high volumes of traffic to vehicle access for individual premises and, obviously, these functions are very important. To fulfil these varying functions requires a range of roads with different characteristics. In addition, there are often significant differences in the characteristics of the different road types depending on whether they are located within the urban or rural environment.

4.2.2 The Highland Council Road Type Classification

4.2.2.1 There is benefit in establishing various road type definitions, in order to clearly differentiate between them, especially for non-residential roads carrying significant volumes of traffic and also for roads in rural locations, where vehicle speeds can be significant. For new roads, the Council has adopted its own road type classification as defined in Table 4.1.

4.2.2.2 When designing a new road or a new network, a developer should identify the main attractors and generators of traffic, both motorised and non-motorised types. The developer should also examine the topography of the site, including any physical restraints, to establish locations where roads/streets cannot be positioned, due to certain conditions, such as:-

- adverse gradients;
- existing trees;
- buildings;
- water-courses; or
- unsuitable ground conditions.

Table 4.1 The Highland Council New Road Type Classification

| ROAD TYPE | TYPICAL CAPACITY AND / OR TRAFFIC FUNCTION | DEVELOPMENT SERVED | FRONTAGE ACCESS + |
|---|---|--|---|
| Strategic route | Connections between primary destinations and to the Trunk Road network. | Main settlements, transport links, and important economic development. | Restricted |
| Main distributor (urban areas) | Main routes within urban areas typically carrying 5,000 to 20,000 vehicles per day. | Major development areas. | Restricted |
| Regional route (rural areas) | Transport corridors between settlements. | Links between main and local settlements and links to the Trunk and strategic network. | Restricted |
| Local distributor (urban areas) | Urban routes linking Main Distributors and carrying up to 5,000 vehicles per day and will be utilised as a bus route. | Up to 1000 dwellings or an industrial estate or mixed development. | May be permitted when speed limit is 30mph and there is provision for vehicle turning within curtilage of properties. |
| Sub – regional route (rural areas) | Links to the trunk, strategic and regional network. | Larger villages | Restricted |
| Industrial access road | Designed for HGV traffic and may be utilised as a bus route. | Industrial/commercial premises | Permitted |
| Main residential street | Provides a link between distributor roads and minor residential streets. May be utilised as a bus route | Up to 200 dwellings | Permitted |
| Minor residential street | Provides through routes between other residential streets. | Up to 50 dwellings | Permitted |
| Courtyard, close or cul-de-sac | Access only | Small number of dwellings as agreed with the Council but not exceeding 20 | Permitted |
| Rural link road | Links to the higher route network | Smaller villages | Subject to consideration on a case by case basis |
| Minor rural road | Generally carrying only access traffic | Small settlements and individual properties | Permitted |

Notes: Road types shown greyed will not normally be provided by developers but may be financed through developer contributions.

+ Frontage access where permitted is subject to considerations of safety as set out elsewhere in this document

4.3 Descriptions / Tuairisgeulan

4.3.1 Strategic Route, Main Distributor and Regional Route Roads

4.3.1.1 Strategic Route Roads, Main Distributor Roads (urban areas) and Regional Route Roads (rural areas) are significant transport corridors and only in very exceptional circumstances would developers be required to construct such roads themselves; normally there would be a requirement to provide a financial contribution instead. The design of these categories of road would require close liaison and negotiations with the Council, before being accepted.

4.3.2 Local Distributor Road

4.3.2.1 The function of a Local Distributor Road within the urban area is to keep adjacent areas free from through traffic, whilst forming the connection between Strategic Route and Main Distributor Roads and key local roads, being either Main Residential Streets or Industrial Access Roads. Whilst a Local Distributor Road is primarily intended to meet the needs of local vehicular traffic, it does form a key part of the road network.

4.3.2.2 Direct individual frontage access and on-street parking may be permitted for a Local Distributor Road where a 30mph speed limit is provided. Permitting frontage access would encourage some pedestrian activity and natural surveillance, thereby introducing a sense of place to the road rather than it being a transport corridor giving priority to vehicular traffic; this is particularly true when the road is also a High Street. Where direct frontage access is provided, curtilage turning facilities should be provided to permit a vehicle to enter and exit in forward gear.

4.3.2.3 Areas of new development large enough to require a Local Distributor Road will usually be identified on Local Plans, with an indicative route for such a road either shown on the plans or identified within an associated planning brief for the area. A developer can suggest modifications to any indicative route, in order to optimise development layouts but any change must be approved by the Council.

4.3.3 Industrial Access Road

4.3.3.1 An Industrial Access Road provides frontage or service access to industrial and commercial premises. This type of road is transitional in nature and the Industrial Access Road can be designed to reduced standards of alignment, compared with the Local Distributor Road.

4.3.3.2 In general, the Industrial Access Road should be a loop rather than a cul-de-sac, to avoid the need for large turning areas to accommodate long HGVs. Where agreed with the Council, the layout could be designed to accommodate general through traffic movements.

4.3.4 **Residential Streets**

4.3.4.1 Residential streets tend to be transitional in nature, distributing vehicular traffic from a Local Distributor Road (urban areas) or Sub-regional Road (rural areas) to dwellings within residential areas that might be served by a range of minor residential street types.

4.3.4.2 For most residential developments, the Council will encourage the design of the associated residential streets to be based on the guidance set out in **Designing Streets**. It is not intended to re-produce these within this document, other than to highlight that medium to large residential developments should provide more connections onto the external network, to spread vehicular traffic flows and help avoid the need for an internal distributor road.

4.3.4.3 In addition to movement streets also have the following important functions:-

- Place
- Access
- Parking
- Services

This means the setting of standard dimensions is usually not appropriate and, therefore, new streets should be considered on a case-by-case basis, taking account of building layout and height, pedestrian and cycle activity, public transport requirements, access by service vehicles, through traffic, design speeds and connections to existing roads..

4.3.5 **Home Zones**

4.3.5.1 Whilst the Council does encourage more use of the Home Zones concept, it should be noted that only the Council can designate a road as a formal Home Zone, under powers granted through the **Transport (Scotland) Act 2001** and **The Home Zones (Scotland) (No 2) Regulations 2002**. A developer would be required to meet the costs of the legal process involved in establishing a formal Home Zone.

4.3.5.2 Where a developer proposes a Home Zone, early discussions must be held to agree a proposed layout.

4.3.6 **Private Accesses and Roads**

4.3.6.1 Up to and including four properties may be served by a private access, over which there is no public right of passage, subject to agreement with the Council. Although private, there is still a requirement for the access to be designed to suitable standards, especially its junction with the public road, and approved by the Council. These standards, together with further guidance, are set out in the **Access to Single Houses and Small Housing Developments** (Appendix 10).

4.3.6.2 With regard to the formation of a new private access or private road in a rural area it is preferable, in the interests of road safety, that it link onto a side road rather than the main public road. The Council also wishes to encourage the use of shared private access where possible. Provision of an additional separate pedestrian/cycle route from the site linked to the main public road may sometimes be desirable in certain situations.

4.3.6.3 A private road is defined as a road over which public access can be permitted but which is un-adopted by the Council. A private road shall be designed to suitable standards, approved by the Council.

4.3.6.3 In both circumstances, the owner(s) of a private access or road is responsible for its maintenance.

4.3.7 **Roads in Rural Areas**

4.3.7.1 Developments in rural areas are considered differently from the urban situation, as higher vehicle speeds require more stringent design criteria and reference should also be made to the **Design Manual for Roads and Bridges (DMRB)**. In addition, there is a need for appropriate aesthetic design of rural developments to ensure that they sit comfortably into their surrounding settings.

4.3.7.2 Rural roads are often subject to speed limits in excess of 30mph and it is vital, therefore, that appropriate visibility is provided, even for small developments or where traffic flows on the main road are relatively low.

4.3.7.3 In addition, whilst the different types of residential streets used in rural areas will essentially remain the same as for urban areas, it is unlikely that many rural residential developments will be of such a size as to require a Main Residential Street that acts as a core road. An additional type of road will be permitted, namely the Single Track Access Road, which can be used to serve small rural developments. Design standards are set out in Chapter 5.

4.4 **Pedestrian and Cycle Networks / *Lìonraidhean Choisichean is Bhaidhsagalan***

4.4.1 The Council encourages walking and cycling as they are the most sustainable modes of travel and should be the first choice for many short trips. Pedestrian and cyclist movements should be made as safe, convenient and attractive as possible and effective walking and cycle accessibility and connectivity must be integral to the development layout at the earliest planning stage.

4.4.2 Pedestrians, cyclists and vehicles should share street routes wherever possible. However, the pedestrian and cycle networks should reflect natural desire lines to main trip generators, whilst taking account of aspects such as connections to Core Paths and leisure activities and, as a result, there may be occasions when more direct segregated routes are appropriate.

4.4.3 The number and type of walking and cycling trips generated by a development – to and from work, shops, schools, bus stops, health centres, and recreational facilities – will result in a

hierarchy of pedestrian and cycle routes complementary to the vehicular network. The volume of pedestrian and cyclist activity will also influence the width of facilities and the need for features, as well as the requirement for formal crossings

- 4.4.4 Cycle networks can comprise Shared Road Links, Cycle Lane Links or Cycle Track Links. The appropriateness of each facility is described in more detail within **Cycling by Design**. The Council should be consulted as early as possible about existing cycle route links and the need for new ones.

4.5 Bus Network / Líonra Bhusaichean

- 4.5.1 For many trips, especially over medium to long distances, public transport is likely to be the only realistic alternative to travelling by private car for the majority of people. It is also likely that buses will form the main type of public transport provision.
- 4.5.2 For new developments, accessibility and connectivity are key issues that will significantly influence the use of public transport. The Council will require developers to maximise opportunities for enhancing public transport facilities serving a development, especially the bus network.
- 4.5.3 In planning new developments, the need to provide or enhance local bus services will have a significant impact on the design, in terms of road layouts, widths, corner radii and pedestrian routes. In order to be as attractive as possible, bus routes must be reasonably fast and direct, connecting the centres of the residential, business and shopping areas they serve.
- 4.5.4 The relationship of new residential development to any road used as a bus route should result in no house being more than a 400-metre walk from the nearest bus stop. This means the existing bus network needs to be assessed to establish how well the development proposal meet this criterion and establish what measures are needed to address any shortcoming.
- 4.5.5 For residential developments where buses do not pass through the site, it is important that a high quality pedestrian network is provided giving direct access to nearby bus stops, with minimal walking distances. In such instances, the provision of footpaths may be appropriate if the internal road layout does not provide direct routes for pedestrians.
- 4.5.6 For non-residential developments generating significant levels of trips by the public, such as a large retail store, it is desirable that bus services can provide good accessibility. As a result, it would be expected that the internal design of such developments shall permit bus services to enter the site and drop off and pick up passengers close to a building's main entrance, with provision of shelters and covered walkways, where possible.
- 4.5.7 If extensive measures that seek to aid buses and, therefore, encourage travel by public transport, are already in existence in the surrounding area or are planned, it is important to ensure the

benefits from these measures are not eroded by the provision of poor facilities in new residential areas.

4.5.8 Mutual benefit can be obtained from regular informal contact between the developer, the Council's Public Transport Manager and relevant bus operators. This will allow the implications of those developments requiring bus service provision and bus routes to be identified at an early stage, so that bus operation can commence as soon as a development opens, thereby encouraging the maximum use of public transport. It is important that the developer seeks guidance from the Public Transport Manager during the pre-planning application stage.

4.5.9 In considering enhancements or alterations to the existing bus network, the developer needs to consider the following aspects:-

- Trip attraction levels and service provision
- Accessibility
- Walking distances
- Infrastructure requirements
- Bus stop features and turning requirements
- Road widths
- Bus priority
- Information provision, including Real-Time Passenger Information (RTPI)

More details are provided within Chapter 5.

CHAPTER 5 – DESIGN OBJECTIVES AND REQUIREMENTS / CAIBIDEAL 5 – AMASAN AGUS RIATANASAN DEALBHAI DH

5.1 Introduction / Ro-ràdh

- 5.1.1 This chapter provides details of the Council's current design requirements for new road layouts, explains why the design requirements are set and gives appropriate background and supporting information for various relevant aspects of the design.
- 5.1.2 The design requirements set out minimum standards for the geometry of new, prospectively adoptable roads, together with other related features, and an applicant must take these into account when designing new development layouts. Road safety is the main objective and designers should seek to meet the standards wherever possible. It is acknowledged that in certain circumstances, local conditions may affect a site, such that not all standards can be fully met. If this is the case, early discussions with the Council should be held, to establish if any variation or relaxation may be permissible. However, the applicant should note that, in the majority of cases, if the minimum standards cannot be met, Council officials are likely to recommend refusal of the planning application and also the Road Construction Consent application.
- 5.1.3 **Specific design requirements are contained within highlighted text boxes or Tables.** Additional design considerations may be necessary for individual developments and are described within the general text paragraphs or highlighted as figures. Users of Chapter 5 are, therefore, recommended to familiarise themselves with the complete Chapter.
- 5.1.4 The Chapter is sub-divided into the following grouped topics, for ease of reference:-
- Geometric Requirements for Roads and Junctions
 - Pedestrians, Cyclists and Equestrians
 - Public Transport
 - Servicing Arrangements
 - Traffic Signs and Road Markings, Road Lighting, Traffic Signals and Statutory Undertakers
 - Road Structures
 - Road Drainage
 - Other Design Requirements
- 5.1.5 It is a statutory requirement, in terms of the **Disability Discrimination Act**, to take account of the needs of disabled persons when designing any building to which the public have access. Routes to buildings should be designed to accommodate disabled persons.

Geometric Requirements for Roads and Junctions / Riatanasan Geoimeatrach airson Rathaiden is Chinn-rathaid

5.2 Road Elements / Eileamaidean Rathaid

5.2.1 Road design is divided into two distinct parts – link design and junction design. Design requirements for both parts are related to vehicle speed and the desired capacity for volume and type of traffic.

5.3 Road Link Types / Seòrsaichean Cheangalan Rathaid

5.3.1 *Strategic Route Roads and Main Distributor Roads*

5.3.1.1 As stated in Chapter 4, Strategic Route Roads and Main Distributor Roads are major road types that would need to be designed in full consultation with the Council.

5.3.2 *Local Distributor Road*

5.3.2.1 The nature of a Local Distributor Road will be influenced by the anticipated mix and volume of all types of traffic using it, including pedestrians and cyclists.

Design Requirements

The standard width of carriageway for a Local Distributor Road shall be 6.0 metres, increasing to 7.3 metres if it is a bus route or gives access to an industrial development.

5.3.2.2. Prior agreement must be reached with the Council as to whether bus stops will require provision of lay-bys and this is likely to be influenced by the intended speed limit and traffic volume on the road. Generally, a 40mph speed limit is considered more appropriate for a semi-rural location, with the majority of urban locations expected to have a 30mph speed limit.

5.3.2.3 Where pedestrian movements are high, facilities for pedestrian crossings shall be provided, preferably in the form of controlled crossings. Where appropriate and there is sufficient demand, the crossing facilities may also be designed to cater for cyclists. However, in certain circumstances, it may be more appropriate to reduce vehicle speeds, so that uncontrolled crossings can be provided. The crossing points should be provided at locations that best serve vulnerable road users, seeking to meet natural pedestrian desire lines wherever possible.

5.3.2.4 Typical locations where there is likely to be major pedestrian (and cyclist) activity are:-

- in proximity of a school (where an associated TRO may be required, to restrict parking);
- where there are a number of retail units;
- on a defined pedestrian route and/or cycle route;
- in the vicinity of bus stops;
- at developments of high trip generators, such as business, commercial, leisure or industrial developments.

- 5.3.2.5 In some instances, new development proposals may be required to enhance existing pedestrian and cycle facilities.

Design Requirements

Where a footway is to run adjacent to the Local Distributor Road (other than when it is a High Street), a minimum 3.0-metre shared footway/cycle track shall be provided, preferably separated from the carriageway by a 2.0 metre verge, unless agreed otherwise with the Council.

If the verge is located to the rear of the footway/cycle track, then the first 0.6 metres of the 3.0m footway/cycle track shall form a segregation strip, by use of different materials, such as block paving.

Localised widening of the combined footway/cycle track shall also be provided in the vicinity of bus stops.

- 5.3.2.6 In some locations, wider footways should be provided where there are significant levels of pedestrian activity. In some circumstances, provision of cycle lanes on the carriageway may be permitted, as an alternative arrangement.

Design Requirements

A 2.0 metre verge shall be provided on both sides of a Local Distributor Road (other than when it is a High Street), at all times, unless agreed otherwise by the Council, together with any additional width required for the provisions of SUDS measures, such as swales.

In rural locations, where the verge is adjacent to the carriageway, it shall be grassed, although a granular material may be acceptable at some specific locations, to act as an over-run area.

Where direct frontage access is permitted onto a Local Distributor Road, curtilage turning facilities are to be provided within the development, so that vehicles can enter and exit the site in forward gear, in the interests of road safety.

5.3.3 **Industrial Access Road**

- 5.3.3.1. The alignment of an Industrial Access Road will largely depend on its length but a formal design speed is still considered appropriate for assessing curve radii and visibility.

Design Requirements

A design speed of 32kph is proposed as an appropriate figure, combined with a desirable minimum centreline radius of 127 metres (absolute minimum of 30 metres), together with localised carriageway widening or vehicle over-run areas at locations with small radius curves.

The Industrial Access Road should be designed as a loop road or with a number of vehicular entrances and exits, rather than as a cul-de-sac requiring turning head facilities.

The carriageway should be a minimum width of 7.3 metres, but it may be acceptable to reduce this to 6.0 metres where commercial vehicle activity is likely to be limited, such as for small units, or where there is one-way working.

A minimum 2.0 metre wide footway should be provided on both sides of the road, increased to at least 3.0 metres minimum if shared footway/cycle tracks are provided, unless agreed otherwise with the Council.

- 5.3.3.2 Depending on levels of movements and also any surrounding pedestrian/cycle network, there may be a requirement for pedestrian crossing facilities. Bus services (new or enhancement) and public transport infrastructure may also be required.

5.3.4 **Residential Streets**

- 5.3.4.1 There are different types of residential streets, with varying design requirements depending on their access arrangements and the number of units that they are serving.
- 5.3.4.2 Carriageway widths and alignment should promote low vehicular speeds together with a greater emphasis on facilities for walking and cycling.
- 5.3.4.3 Proposed speed limits for residential developments must be agreed with the Council. For the majority of these developments, the Council will require a formal 20mph speed limit or speed restriction zone to be introduced, with appropriate signage provided. The developer will be required to meet all costs associated with the introduction of such 20mph speed limits or zones, including signage and TRO costs.

Design Requirements

Residential streets should have a maximum design speed of 32kph, although the design of any alignment should encourage lower speeds.

Where a residential street is also to be a bus route, an appropriate speed limit and carriageway width must be agreed with the Council, as this will influence the design of the street.

Geometric requirements shall be assessed on a site-by-site basis, in consultation with the Council and taking account of the principles within **Designing Streets**. **In certain cases, the Council may require geometric dimensions that differ from those recommended within Designing Streets.**

Where a supporting mandatory 20mph speed limit is introduced, this will require associated signage and the promotion of an associated TRO, which the developer shall normally fund.

There is a requirement to ensure that service vehicles, especially refuse collection vehicles, can be accommodated and this shall be confirmed by the use of swept path analysis.

5.3.5 **Home Zones and Shared Surfaces**

- 5.3.5.1 For many new residential developments, the Home Zone concept of shared surface streets would be acceptable and is encouraged by the Council. There is no standard Home Zone design but there is useful design information that can be referred to. Examples include:-

www.homezones.org.uk

(Institute of Highway Incorporated Engineers)

Homes Zones: Challenging the Future of Our Streets

(www.dft.gov.uk publication)

Homes Zones in Scotland: Evaluation Report

(www.scotland.gov.uk)

Homes Zone Paving

(www.paving.org.uk)

- 5.3.5.2 Shared surfaces can also be provided within other types of development to help enhance social interaction. However, any such proposal must be agreed early with the Council and needs to take full account of the needs of people with mobility difficulties, especially the visually impaired.

5.3.6 Single Track Access Road

5.3.6.1 The Single Track Access Road is predominantly constructed within the rural environment, where low traffic flows permit a reduced carriageway width.

Design Requirements

The carriageway should be 3.3 metres wide and shall be provided with inter-visible passing places, where possible, that are a maximum distance of 150 metres apart and sited to suit the vertical and horizontal geometry.

Where there are a number of dwellings in close proximity to each other and directly fronting onto the road, a 5.5 metre wide carriageway must be provided along the frontages to accommodate a stopped vehicle

5.3.6.2 Figure 5.1 shows two options for the required layout of a standard passing place, with the larger size provided where significant numbers of HGVs may use the road.

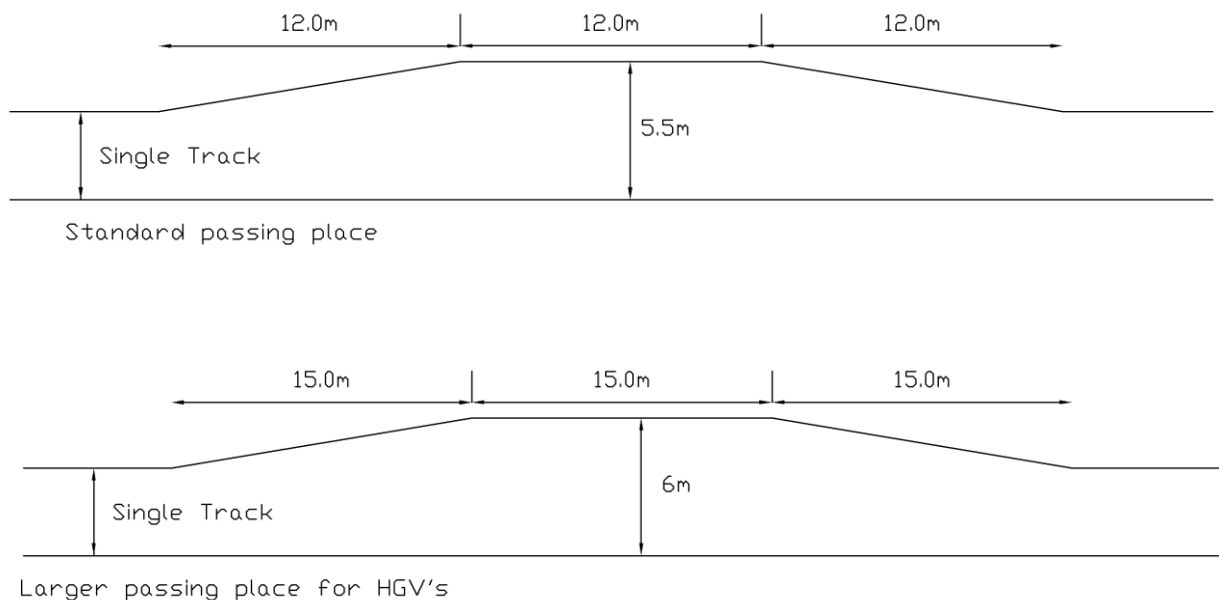

Figure 5.1 Single Track Access Road Passing Place – Standard and Large

5.3.6.3 Where a development is proposed on an existing road which currently does not meet all of the above criteria, then the developer will still be required to widen the road along the frontage of the development and may, where deemed necessary, need to widen the whole length of the access road to the development to an appropriate width. In such cases, the extent of improvements will have to be agreed and approved by the Council prior to their construction.

5.4 Rural Residential Streets

5.4.1 For residential streets, guidance and standards contained within both **Designing Streets** and this document tends to focus on residential developments within the urban context. In rural locations residential streets should still comply with general geometric standards but their layout and construction materials should be more related to the rural context.

5.4.2 The proposed design of a rural residential scheme must be discussed at an early stage with the Council. The principles of **Designing Streets** do apply to rural residential streets, in that they should be designed to accommodate pedestrians, cyclists, service vehicles and private vehicles. However, the main difference is likely to be in the use of appropriate materials, with the objective of ensuring that a rural residential street fits well into its surroundings. Examples of good rural design include:-

- Having horizontal alignments with more curves and bends. This results in shorter sections of straight roads, which will also reduce vehicle speeds;
- Not using standard precast concrete kerbing, but other materials, such as plastic kerbing, granite kerbs or setts. In some cases, kerbing may be omitted altogether;
- Lower kerb upstands may be more appropriate, but recognising drainage and future maintenance requirements;
- Footways could be segregated from the carriageway by grass verges or open spaces for SUDs measures such as swales;
- Provision of pedestrian access to bus stops/shelters on adjacent bus routes where appropriate;
- Driveways and accesses could be provided with gates that are set back;
- Use street furniture more appropriate to a rural setting;
- Street lighting may, in some cases, be omitted;
- Seeking to reduce the amount of road markings and signage required; and
- Enhanced landscaping could be provided, such as trees within the grass verges.

5.4.3 Whilst the use of appropriate materials can assist in softening the visual impact of a rural residential street, there is an issue with their future maintenance. It is important, therefore, that if a developer proposes any special materials, this is discussed and agreed with the Council. In some circumstances, a developer may be required to provide additional quantities of a particular material to the Council, for storage and future maintenance.

5.5 Link Design Geometric Requirements / Riatanasan Geoimeatrach Dealbhadh Ceangail

5.5.1 The link design geometric requirements to be used for different types of road are set out in Tables 5.1, for urban roads, and Table 5.2, for rural roads. The geometric requirements shall be discussed and agreed with the Council, in case there are any site-specific issues that may require a local variation to a particular criterion.

Table 5.1 Geometric requirements for urban road links

| Road Type | Strategic Route | Main Distributor | Local Distributor | Local Distributor | Industrial Access Road | Main Residential Street | Minor Residential Street, Home Zone and Cul-de-sac | Comments |
|--------------------------------------|-------------------|-------------------|--------------------|-------------------------|------------------------|-------------------------------------|---|--|
| | 1 | 2 | 3a – 60kph | 3b – 50kph | 4 | 5 | 6 ^a | |
| Widths | | | | | | | | ^a - refer to Designing Streets |
| Carriageway | 7.3m | 6.0–7.3m | 6.0-7.3m | 6.0-7.3m | 6.0-7.3m | 5.5-7.3m | C/way width to be | |
| Footway (minimum width) | 3.0m ^b | 3.0m ^b | 3.0m ^b | 3.0m ^b | 2.0m | 2.0m | suitable for refuse vehicle 2.9m wide and 8.6m long | ^b - shared footway/cycle track, with first 0.6m block paving, where next to carriageway Either grass or combined 0.6m block paving & 1.4m grass for Road Type 6 |
| Verge | 2.0m | 2.0m | 2.0m | 2.0m | 2.0m | 2.0m where specified by the Council | | |
| Design Speed | DMRB | DMRB | 60kph ^c | 50kph ^c | 32kph unless bus route | 32kph unless bus route | 32kph max | ^c - 50kph for 30mph speed limit and 60kph for 40mph speed limit |
| Sight Distances | | | | | | | | |
| Overtaking | DMRB | DMRB | 345m | 290m | - | - | Refer to Designing Streets | |
| Stopping | DMRB | DMRB | 90m | 70m | 70m | 35m | | |
| Horizontal Radius | | | | | | | | |
| Desirable Minimum | DMRB | DMRB | 255m | 180m | 127m ^d | - | To be agreed with the Council | |
| Absolute Minimum | DMRB | DMRB | 180m | 127m ^d | 30m ^d | 25m ^d | | ^d - with carriageway widening or over-run areas at corners |
| Gradients | | | | | | | | |
| Maximum | DMRB | DMRB | 8% | 8% | 8% | 8% | 10% | |
| Minimum | DMRB | DMRB | 0.8% | 0.8% | 0.8% | 0.8% | 0.8% | In exceptional cases, a lower minimum may be accepted |
| Vertical Curves K values | | | | | | | | |
| Overtaking Crest | DMRB | DMRB | 142 | 100 | - | - | - | |
| Minimum Crest | DMRB | DMRB | 17 | 10 | 10 | 6 | - | |
| Minimum Sag | DMRB | DMRB | 13 | 9 | 9 | 6 | - | |
| Access Features | | | | | | | | |
| Frontage Access | No | No | No | Restricted ^e | Yes | Yes | Yes | ^e - only acceptable where low traffic flows |
| In- curtilage Turning | n/a | n/a | n/a | Essential | Desirable | Desirable | No | |
| On-street Lay-by for parking/loading | n/a | n/a | Yes ^f | Yes ^f | No | No | No | ^f - depends on type of frontage |
| Bus Bay | Yes | Yes | Yes | No | No | No | No | |

Table 5.2 Geometric requirements for rural road links

| Road Type | Dual Carriageway | A-class | B-class | C-class | Unclassified | Single Track Access Road | Comments |
|--------------------------------------|------------------|-------------------------|-------------------------|---------------------------|---------------------------|--------------------------|---|
| Widths | | | | | | | |
| Carriageway | 2x7.3m | 6.0m-7.3m | 5.5m-6.0m | 3.3m or 5.5m ^a | 3.3m or 5.5m ^a | 3.3 m | ^a - if single track, then passing places are to be provided |
| Footway (if provided) | 2.0m | 2.0m | 1.5m | 1.5m | 1.5m | 1.5m | Additional 0.5m separation strip to be provided, where verge is to rear of footway |
| Verge | 2.0m | 2.0m | 2.0m | 2.0m | 2.0m | 2.0m | Width excludes ditches. Normally grass |
| Design Speed | | | | | | | |
| | DMRB | DMRB | 85kph | 60kph | 60kph | 60kph | |
| Sight Distances | | | | | | | |
| Overtaking | DMRB | DMRB | 490m | 345m | 345m | n/a | |
| Stopping | DMRB | DMRB | 160m | 120m | 120m | 120m | |
| Horizontal Radius | | | | | | | |
| Desirable Minimum | DMRB | DMRB | 510m | 255m | 255m | - | |
| Absolute Minimum | DMRB | DMRB | 360m | 180m | 180m | Note | Note – value to be agreed |
| Gradients | | | | | | | |
| Maximum | DMRB | DMRB | 8% | 10% | 10% | 10% | |
| Minimum | DMRB | DMRB | 0.8% | 0.8% | 0.8% | 0.8% | In exceptional cases, a lower minimum may be accepted |
| Vertical Curves | | | | | | | |
| K Values | | | | | | | |
| Overtaking Crest | DMRB | DMRB | 285 | 142 | 142 | Note | Note – value to be agreed |
| Minimum Crest | DMRB | DMRB | 55 | 17 | 17 | Note | Note – value to be agreed |
| Minimum Sag | DMRB | DMRB | 20 | 13 | 13 | Note | Note – value to be agreed |
| Access Features | | | | | | | |
| Frontage Access <i>See Note 1</i> | No | Restricted ^b | Restricted ^b | Yes | Yes | Yes ^c | ^b – depends on road layout, visibility and traffic volumes/speeds ^c - where development directly fronts the road, width to be increased to 5.5 m |
| In-curtilage Turning | Essential | Essential | Yes | Yes | Yes | Yes | To allow entry/exit in forward gear |
| On-street Lay-by | No | Yes | Yes | Yes | Yes | Yes | |
| Bus Bay | Yes | Yes | Desirable | No | No | No | |

Note 1 – acceptance of the formation of a new rural private access will be influenced by traffic volumes, speeds, road layout and the proximity of existing accesses. For Class A and B roads, the Council must be consulted for guidance on spacing advice. On other minor rural roads, a new private access should not normally be constructed within 90 metres of a road junction or within 30 metres of an existing private access. The Council would encourage the use of shared accesses.

5.6 Road Junctions / Cinn-rathaid

5.6.1 *Introduction*

5.6.1.1 There will be a requirement to provide vehicular access for nearly all new developments to some extent by means of a road junction. Depending on the size of a development, internal junctions may also be required. It is important that junctions are designed so they are safe for all road users. Junction design is influenced by traffic capacity, vehicle speed and also by type and size of development block, where relevant.

5.6.2 *Junction Types*

5.6.2.1 Where two roads intersect or where a new access joins an existing road, the standard requirement is that a right angled priority T-junction should be formed with the major road, which is defined as carrying the higher volume of traffic through the junction.

5.6.2.2 In certain circumstances, other types of junction, such as a roundabout or the provision of traffic signals may be required, with the appropriate junction layout and type agreed in advance with the Council. Crossroads are more convenient for pedestrians and can help create more permeable street networks, so are appropriate for residential areas. For larger developments or complex junction layouts, the design of junctions shall be checked for the anticipated traffic flows, using standard junction design computer programs or by use of microsimulation modelling.

5.6.2.3 The geometric layout of the junction should clearly establish the priority of the major road to approaching drivers and other road users. Signs and/or road markings will usually be required to emphasize this priority, provided at the developer's expense, and agreed with the Council.

5.6.3 *Junction Spacing*

5.6.3.1 In the interest of road safety, the number of new connections onto the existing main road network should be minimised and, where feasible, new vehicular accesses should connect with existing side roads in the first instance. However, within new residential developments, particularly medium/large ones, it is recommended that a number of access routes are provided, in order to spread traffic flows by giving drivers route choice.

5.6.4 *Junction Visibility*

5.6.4.1 It is important that vehicles exiting a side road can see and be seen by approaching vehicles on the main road, especially where the main road has high traffic speeds. A junction visibility splay must be provided and kept clear of obstructions. These requirements can significantly impact the design of any frontage. Guidance on visibility is given in Section 5.7

5.6.5 **Junction Design Standards**

5.6.5.1 Road junctions should be designed to meet the minimum standards set out in Table 5.3 (Urban) and Table 5.4 (Rural).

5.6.6 **Siting of Junctions and Accesses**

5.6.6.1 It is preferable to provide new junctions and accesses on level ground or where the gradient is less than 6%. In addition, they should be sited in sags rather than at or near crests. Where a T-junction or access is positioned on a curve, it should be sited so the minor road/access is on the outside of the curve. Junctions or accesses on the inside of sharp curves will generally be unacceptable.

5.6.6.2 Outwith residential areas or industrial estates, where two opposite minor roads approach a major road that carries high volumes of traffic or fast-moving vehicles, a staggered junction, comprising two T-junctions, should normally be used, instead of a crossroads layout. Right/left staggers (where a vehicle crossing the main road first turns right out of the minor road, travels along the major road and then turns left into the other minor road) are preferred to left/right staggers, in the interests of road safety.

Design Requirements

For a staggered junction layout outwith a residential area or industrial estate, the stagger distance between the centrelines of the two minor roads should be a minimum of 50 metres and, preferably, no more than 100 metres.

5.6.6.3 Junction spacing, as set out in Tables 5.3 and 5.4, is related to the likely volumes and speed of traffic, as well as the distance required for a moving vehicle to comfortably take up an appropriate position for any movement.

5.6.7 **Long Vehicle Requirements**

5.6.7.1 At those junctions where it is expected that significant numbers of long vehicles will emerge from the minor road, such as an Industrial Access Road, it is good practice that the nearside kerb incorporates a taper, to assist the vehicles turning left out off the access. A 1 in 5 taper over a minimum length of 30m, measured from the minor road centreline is deemed appropriate.

Table 5.3 Junction Design Standards for Priority Junctions - Urban

| Major Road Type | Minor Road Type | Minimum Spacing on Main Road (metres) | Visibility Splay X (metres) | Y (metres) | Corner Radii R (metres) |
|---------------------------------------|------------------------------------|--|--|----------------------------|-------------------------|
| Urban Roads | | | | | |
| 60mph speed limit | Any | 210 | 9.0 | 215 | Compound Curve |
| Main Distributor | Local Distributor | 210 | 9.0 | 160 | Compound Curve |
| Local Distributor (40mph speed limit) | Local Distributor | 100 | 9.0 | 120 | 10 |
| Local Distributor (30mph speed limit) | Local Distributor | 100 | 9.0 | 90 | 10 |
| Local Distributor | Industrial Access Road | 100 for same side 50 for opposite side | 4.5 | 90 | 15 |
| Local Distributor | Main Residential Street | 100 for same side 50 for opposite side | 4.5 | 90 | 6 |
| Industrial Access Road | Industrial Access Road | 50 for same side 25 for opposite side | 4.5 | 90 | 15 |
| Main Residential Street | Main Residential Street | 50 | 4.5 | 30 If 20mph speed limit | 6 |
| Main Residential Street | Minor Residential Street | 25 | Refer to standards and guidance in Designing Streets with dimensions to be agreed | | |
| Main Residential Street | Loop Road, Home Zone or Cul-de-sac | 25 | Streets to have maximum Design Speed of 32kph | | |
| Minor Residential Street | Loop Road, Home Zone or Cul-de-sac | 25 | | | |
| Speed limit 30mph or more | Individual Driveway | 25 from a major junction 15 from a minor junction | 2.4 | 70/45 * | - |
| Speed limit 20mph or less | Individual Driveway | 25 from a major junction 15 from a minor junction | 2.4 | 25 | - |

Note – in terms of Table 5.3, a junction is deemed to be major when the minor road is Type 1, 2, 3a, 3b, 4 or 5 as defined in Table 5.1. A minor junction is one where the major road is restricted to Type 4, 5 or 6 and the minor road is Type 6 only.

* Main residential Street/Minor Residential Street

Table 5.4 Junction Design Standards for Priority Junctions - Rural

| Major Road Type | Minor Road Type <i>See Note 1</i> | Minimum Spacing on Major Road (metres) | Visibility Splay | | Corner Radii R (metres) |
|--------------------------------------|--------------------------------------|--|---------------------------|------------|-------------------------|
| | | | X (metres) | Y (metres) | |
| Rural Roads | | | | | |
| Dual Carriageway 120kph design speed | Any | 295 | 9.0 | 295 | Compound Curve |
| A Class Road 100kph design speed | Any | 270 | 9.0 2.4 for a driveway | 215 | 15 6 driveway |
| B Class Road 85kph design speed | Any | 160 | 9.0 2.4 for a driveway | 160 | 15 6 driveway |
| C Class Road 60kph design speed | Any | 120 | 4.5 2.4 for a driveway | 120 | 10 6 driveway |
| Unclassified Road | Any | 120 | 4.5 2.4 for a driveway | Note 2 | 10 6 driveway |
| Single Track Access Road | Any | 120 | 4.5 2.4 for a driveway | Note 2 | 10 6 driveway |

*Note 1 – guidance on the formation of a new rural private access, including geometric dimensions, can be obtained from the **Access to Single Houses and Small Developments Booklet** (Appendix 10).*

Note 2 - for unclassified rural roads, the Council will advise what Y value of the visibility splay and what corner radii are considered appropriate for any proposed junction, as they are dependent on the likely vehicle speeds at the specific location. This may require a speed survey to be undertaken, at the developer's expense. As an indication, likely Y values are given in Table 5.5.

Table 5.5 Indicative Y Dimensions for Rural Speed Values

| | | | | | |
|---------------------------------------|--------|-------|-------|-------|-------|
| 85% Percentile Speed Survey – mph/kph | 60/100 | 50/85 | 40/60 | 30/50 | 20/30 |
| Y Distance – metres | 215 | 160 | 120 | 90 | 60 |

5.7 Visibility / Lèirsinneachd

5.7.1 Introduction

5.7.1.1 To enable a driver to see a potential hazard in the road ahead in time to slow down or stop comfortably, the driver's line of vision, in both horizontal and vertical planes, must be considered, together with the stopping distance of the vehicle. The most obvious obstructions to visibility are likely to be road summits, parked vehicles, dense planting, walls/fences and adjacent buildings.

5.7.2 Forward Visibility

5.7.2.1 The requirements for minimum forward visibility, commonly referred to as the Stopping Sight Distance (SSD), for different types of road are set out in Tables 5.1 and 5.2. For residential streets or other locations where lower traffic speeds are to be encouraged, **Designing Streets** recommends reduced distances. However, proposed values for such prospectively public roads must be agreed with the Council during the planning application stage, as these values affect the scheme layout and subsequent RCC application.

5.7.2.2 A design check of the SSD should be undertaken, especially at curves and crests in the road, in order to establish to what extent forward visibility cuts across a corner that could require an area to the rear of the footway and/or verge being included in the forward visibility splay.

Design Requirements

The eye level of a driver can vary from 1.05m above the road surface, when in a typical car, to approximately 2.0m for a commercial vehicle. To allow drivers to see each other across summits, across bends and at junctions, it is essential that unobstructed forward visibility is at least provided within these heights above the road surface, in terms of Full Overtaking Sight Distance.

In terms of Stopping Sight Distance, for a driver to see an obstacle lying on the carriageway, unobstructed forward visibility should be provided to a point closer to the ground and this lower limit is set at 0.26m. Eye level shall be taken between 1.05m and 2.0m.

It is important that the designer checks visibility can be provided in both the horizontal and vertical plane.

5.7.3 Visibility Splays at Junctions

5.7.3.1. Visibility requirements for a junction or access are dictated by the nature and volume of traffic on the minor road, together with the speed of the traffic on the major road.

Design Requirements

Road users approaching a major/minor priority junction along the major road must be able to see the minor road access from a distance equivalent to the SSD set out in Tables 5.1 and 5.2.

A new junction or access must provide visibility splays, as shown in Figures 5.2/5.3/5.4. These must be constructed and maintained free of any obstruction over the whole visibility splay. The driver's eye height shall be taken as 1.05 metres and the target height as 0.6 metres.

Values for X and Y, together with Radius R, are as set out in Tables 5.3 and 5.4,

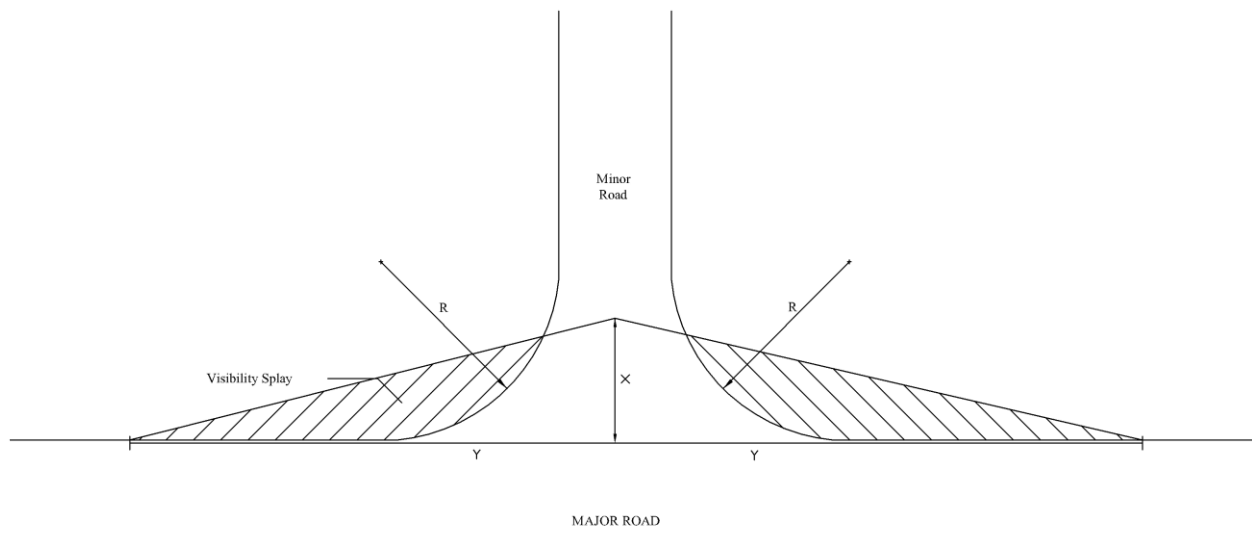

Figure 5.2 Visibility Splays at a Priority Junction

5.7.3.2 As shown in Figure 5.2, visibility splays are determined on plan by two basic dimensions. The X distance is measured from the nearside edge of the main road carriageway back along the centreline of the minor road. The Y distances are measured along the same nearside edge of the main road carriageway and extend in both directions from the minor road. The splays are formed by connecting the ends of the Y distances with the X dimension.

5.7.3.3 In assessing the visibility splays, it is important to check them in both the horizontal and vertical planes. Account should be taken of any planting regime within the splays and their future maintenance requirements. Special consideration also needs to be taken when the minor road is located on a curve.

5.7.3.4 In addition, a driver approaching a Give Way junction from the minor road must be able to see the layout of the junction clearly and a forward visibility splay must be provided. This minor road approach visibility splay is measured from a point 15 metres back from the nearside edge on the main road carriageway, along the centreline of the minor road and should give a clear view of the junction, especially its vertical alignment, using an object height of 1.05 metres, as shown in Figure 5.3.

5.7.3.5 The use of mirrors to aid visibility at a junction is **not** acceptable.

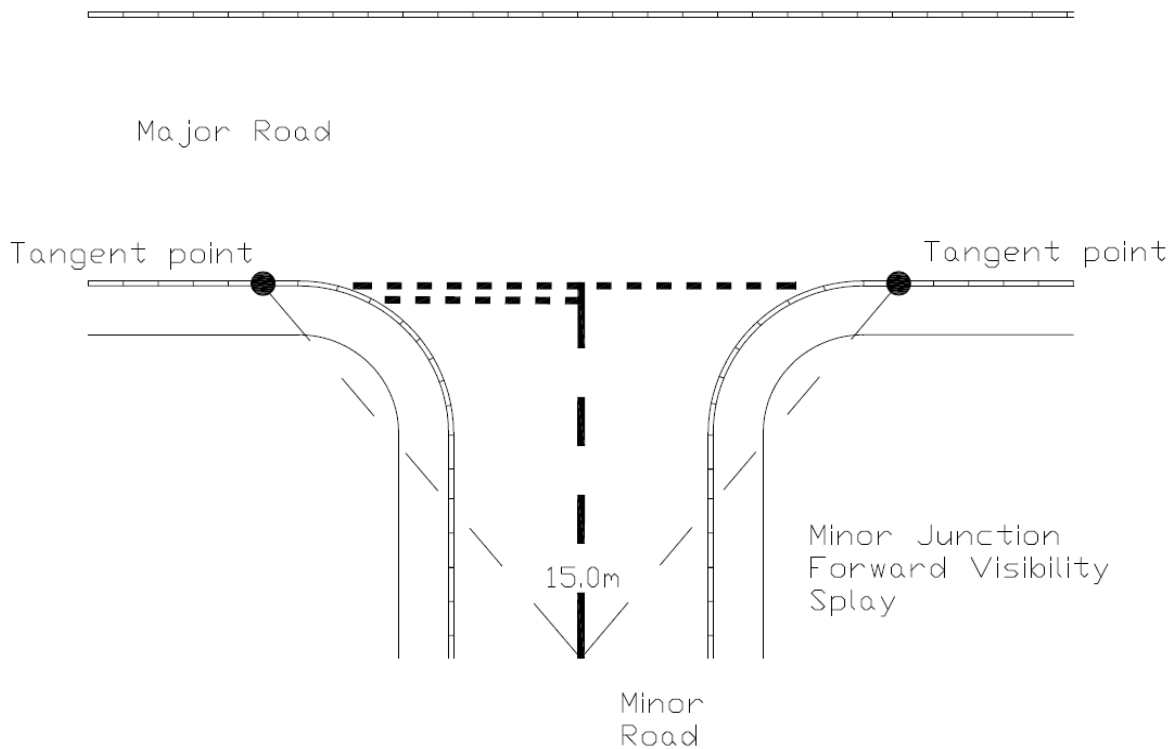

Figure 5.3 Minor Road Approach Visibility Splay

Design Requirements

On roads with speed limits greater than 30mph, cross corner visibility must also be provided for those vehicles turning left into the minor road from the main road, as shown in Figure 5.4.

5.7.3.6 Cross corner visibility is achieved by the provision of a visibility radius tangential to the kerb line, using an object height of 1.05 metres. Figures of typical cross corner visibility radii are set out in Table 5.6. This can result in an additional area, over and above the junction visibility splays shown in Figures 5.2 and 5.3, respectively, being required to be kept free of obstructions. Junction visibility design should, therefore, consider all three aspects and compare them on one drawing for checking purposes.

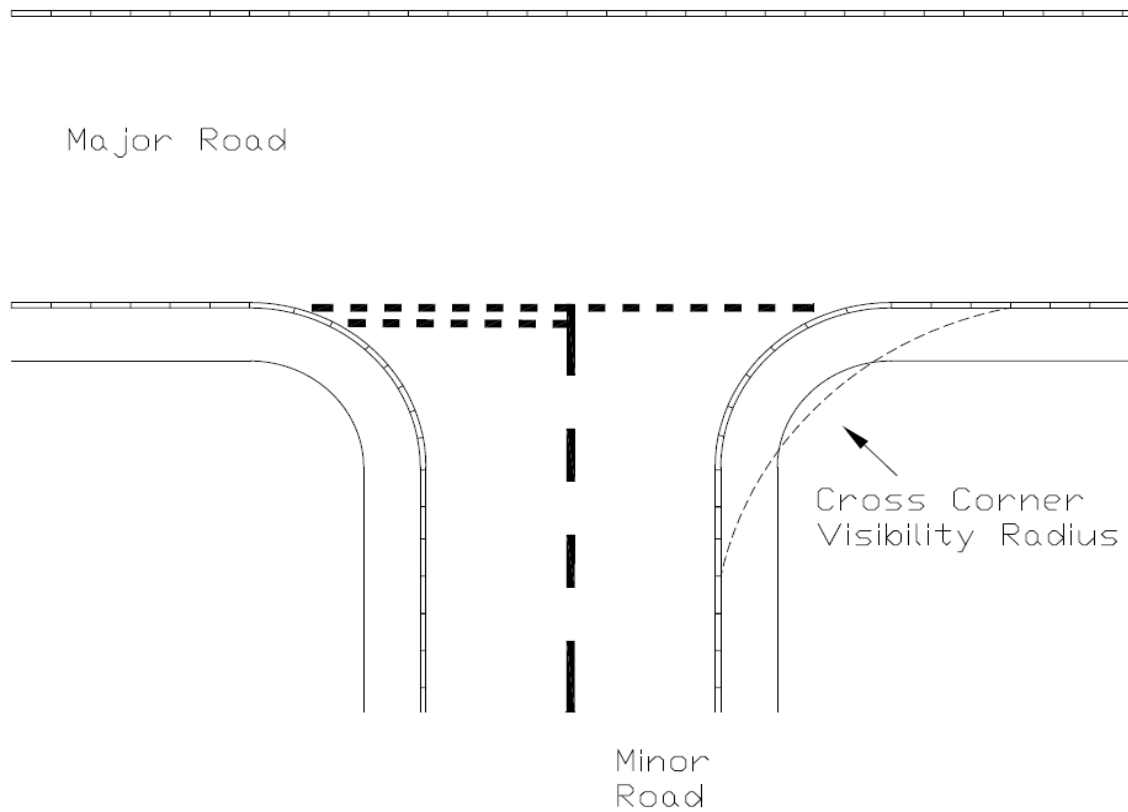

Figure 5.4 Cross Corner Visibility Radius

Table 5.6 Cross Corner Visibility Requirements

| Kerb Radius – metres | Visibility Radius - metres |
|----------------------|----------------------------|
| 5.5 | 9.0 |
| 6.0 | 10.0 |
| 7.5 | 12.0 |
| 9.0 | 15.5 |
| 10.0 | 20.0 |

5.7.3.7 Where a driveway is formed as shown in Figure 5.5 and has either high walls, hedges or buildings (being higher than 0.85 metres) set at the back of the footway and they cannot be reduced in height, then 45° visibility splays, with 2.4 metres x 2.4 metres minimum dimensions, are to be provided for intervisibility between vehicles and pedestrians.

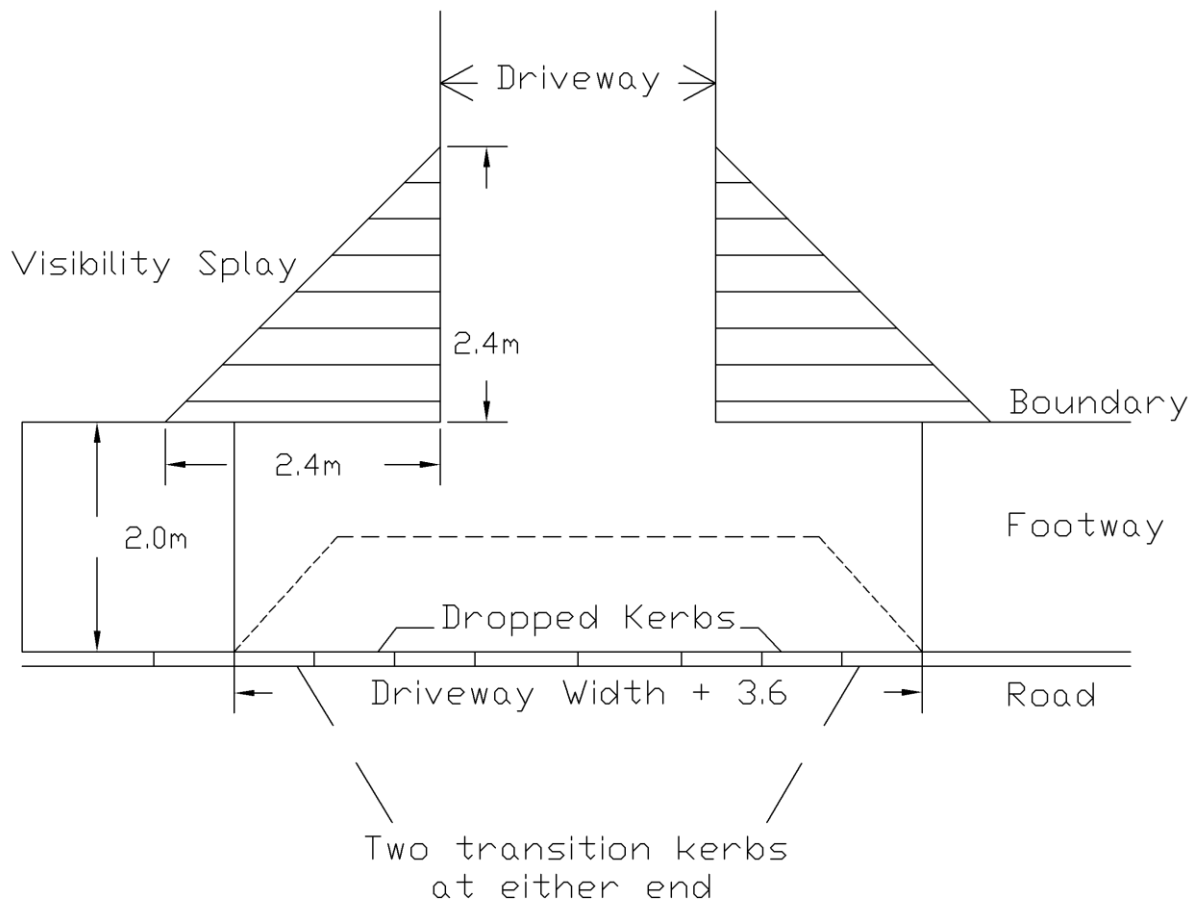

Figure 5.5 Driveway visibility for pedestrians

Design Requirements

No frontage access or parking will normally be permitted within close proximity of a road junction, with a minimum distance of 25m for major junctions and 15m for minor junctions allowable, subject to visibility requirements.

5.7.3.8 It is essential that any planting regime provided as part of the development proposals takes account of future growth and potential impact on junction visibility, without the need for excessive maintenance. Where the visibility splay includes a widened verge, the Council will expect to be provided with the right to control the affected land so it can undertake future maintenance requirements. Where such land is retained in private ownership, that owner will be responsible for ensuring that visibility is maintained, even if that includes land in separate ownership. There is also a requirement for property owners to ensure that any private planting behind a road visibility splay does not encroach and is adequately maintained, otherwise the Council has the powers to cut back any such invasive vegetation and charge the owners for the work.

5.8 Carriageway Widening for Corners and Bends / Leudachadh Rathaidean airson Oiseanan is Lùban

5.8.1 Specified road widths refer to links with straight sections or having large radii curves. Whilst this is desirable for major traffic routes, such as Strategic Route Roads, Main Distributor Roads and Regional Route Roads, for other types of road or street, lower speeds are often a key objective

and bends are designed in. Whilst most vehicles can negotiate such bends within the same carriageway width, larger vehicles, especially HGVs, refuse vehicles and buses, may require a greater width. As a result, there may be a need to widen the carriageway at the location of bends, depending on the type of vehicles using the road and its curve radius and length.

5.8.2 Table 5.7 shows the increased widths required on bends of small radii to allow two vehicles to pass, while maintaining appropriate clearances. Widening may also be required in more open situations, being influenced by the type and volume of vehicles, particularly HGVs and buses, as illustrated in Figure 5.6.

5.8.3 Widening is most simply achieved by maintaining the outer kerb line as a circular arc with the radius equal to the centreline radius plus half the standard carriageway width, and increasing the road width on the inside of the bend. Alternatively, it can be achieved using transition curves, with full widening being maintained over the length of the circular arc.

Table 5.7 Carriageway Widening on Curves of Small Radii

| Centre Line Curve Radius (metres) | Road widths required at apex of 90° bend (m) | | | | |
|--|--|------------|---------------------------|-------------------------------|--------------------|
| | Local Distributor | | Industrial Access Road | Main Residential Street | 6.0 metre width |
| | 6.0m basic | 7.3m basic | 7.3m basic | 5.5m basic | 6.0m basic |
| 25 | - | - | 11.2 | 7.3 | 7.8 |
| 30 | - | - | 10.7 | 7.2 | 7.7 |
| 50 | - | - | 9.4 | 6.8 | 7.3 |
| 75 | - | - | 8.7 | 6.3 | 6.8 |
| 150 | 6.4 | 7.9 | 7.9 | 5.9 | 6.4 |
| 180 | 6.0 | 7.3 | 7.3 | 5.5 | 6.0 |

Note – increased widths may be applied to rural roads, subject to agreement with the Council.

5.8.4 For minor residential streets, where the centre line curve radius is less than 30 metres, careful consideration needs to be given as to how carriageway widening or a vehicle over-run area is provided. Any requirement is likely to be dictated by the types of vehicles using the street. In developments where low volumes of traffic are expected, the occasional HGV or service vehicle could straddle the whole carriageway, as long as passing places are provided. Swept path analysis should be taken to confirm that any proposal is suitable. The use of over-run areas may be acceptable but such a proposal must be discussed and agreed with the Council, as such areas can create potential conflict between pedestrians with mobility difficulties and turning vehicles.

5.8.5 Further guidance on the details of inside kerb lines for industrial roads can be found in **Designing for Deliveries**, published by the Freight Transport Association.

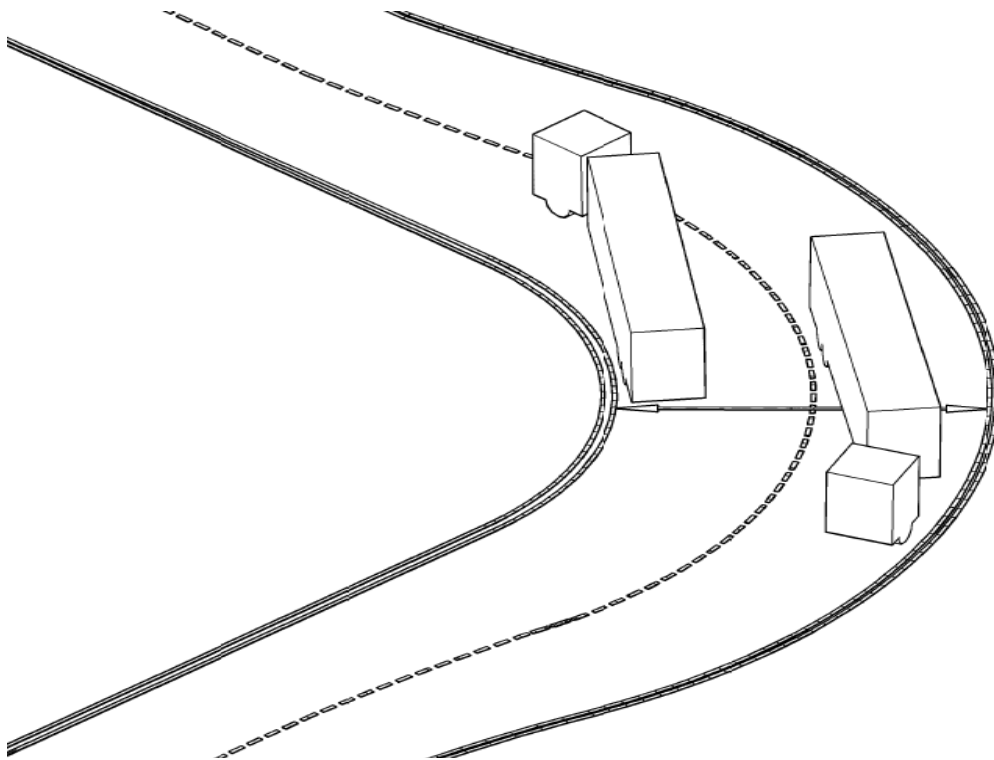

Figure 5.6 Carriageway Widening on Corners

5.9 Vehicle Clearance / Rùm-glusaid Charbadan

5.9.1 Vertical Clearance

5.9.1.1 There are currently no regulations governing the maximum height of vehicles, apart from the 4.2 metres height restriction for a 38 tonne lorry loaded in excess of 32.5 tonnes. However, most vehicles are less than 4.5 metres high.

Design Requirements

The minimum headroom for any new structure shall be 5.3 metres, including pends, even when private, where servicing is required. The exception to this requirement is for a footbridge, where a 5.7-metre clearance below it is required for vehicles.

5.9.1.2 For any pend access or covered parking area that will only be used by private cars, a reduced clearance height of 2.1 metres would be generally acceptable, being increased to 2.7 metres if also used by cyclists. However, the layout should ensure service vehicles, including a refuse vehicle, can service the development without causing an obstruction on the adjacent road.

5.9.1.3 The design and location of any proposed pend access shall take account of the need for motorists to be able to see passing pedestrians.

5.9.2 **Horizontal Clearance**

Design Requirements

A horizontal clearance of at least 0.45 metres must always be provided between the edge of carriageway and any vertical objects, such as traffic signs and street furniture. Where the vertical object is protected by a safety barrier, the road face of the barrier is to have the 0.45 metre clearance.

Where the crossfall of the carriageway exceeds 4%, the clearance shall be increased to a minimum of 0.60 metres, to take account of high-sided vehicles.

5.10 **Gradients / Caiseadan**

Design Requirements

Channel gradients should not be flatter than 0.8%. If the carriageway changes from camber to crossfall, this must not coincide with a sag point in the longitudinal gradient or where a length of road has a channel gradient of less than 1%.

Lay-bys should usually be provided with a 2.5% crossfall away from the road channel, especially where SUDS is provided within the adjacent verge.

Road gradients of more than 10% should be avoided, wherever possible, as this can lead to problems with associated footways, particularly for those persons with mobility difficulties and during periods of winter weather.

Where the minor road is a Local Distributor Road, Industrial Access Road, Main Residential Street or Rural Classified Road, then the approach gradient over the final 9 metres should not exceed 2.5%. For all other lower categories of road and also private accesses, the approach gradient should not exceed 5% over the final five metres.

Should the minor road slope up from the major road, then it must be designed to ensure that minor road surface water does not flow onto the major road.

For private driveways that slope down from the public road towards a property, a small section of raised gradient or bullnose and transition kerbing should be installed, where reasonably practicable, in order to ensure that road surface water does not flow down the driveway, towards any property.

5.11 **Turning Areas / Àiteachan Tionndaidh**

5.11.1 **Introduction**

5.11.1.1 Road layouts shall be designed so that vehicles, especially HGVs and service vehicles, do not need to reverse on to the public road. This can be achieved by the provision of access roads that form a well connected internal network, thus avoiding the need for turning areas. This would reduce un-necessary dead mileage for vehicles and also facilitate and encourage public transport provision.

5.11.1.2 Culs-de-sac are no longer recommended as standard road layouts but where provided, these should preferably terminate in turning circles that can be used by all vehicles, in forward gear. Where a lack of space precludes the creation of a turning circle or as a temporary solution as part of a phased development, a turning head may be substituted. However, the developer must recognise the inherent dangers of reversing vehicles, especially service vehicles, and seek to

minimise the associated risks. If the road is likely to be used by public transport, turning circles must always be provided, unless specifically agreed otherwise with the Council.

5.11.1.3 The dimensions of turning facilities should suit the characteristics of the largest vehicles likely to use the facility on a regular basis. For residential streets, these will normally be refuse collection vehicles, while in industrial/commercial developments, it may be necessary to cater for 15.5 metre long articulated vehicles or 18 metre long draw-bar trailers. A swept path analysis should be undertaken to demonstrate manoeuvrability of the intended design vehicle within the road layout.

5.11.1.4 The turning areas detailed in the following paragraphs are based on the turning circles between kerbs for these vehicles. Where there is no adjacent footway, a 2-metre wide verge or margin shall be provided, to allow for any overhang of vehicle body or possible over-riding of the kerb.

5.11.1.5 Casual parking within turning areas should be discouraged, either by locating them well clear of frontage development or by ensuring that premises or any designated parking bays are accessed via the turning area. In some circumstances, such as where buses use the turning circle, there may be a requirement for formal parking restrictions to be implemented, which would need a Traffic Regulation Order to be implemented.

5.11.2 ***Residential Turning Areas***

5.11.2.1 Layouts for residential areas should seek to avoid the need for turning areas. If this is not possible, the standard turning area for a residential area will suit most service vehicles. Various layout options are shown in Figure 5.7. Where the road approaching the turning area is single track, it shall be widened to 5.5 metres for at least 10 metres before the turning area.

5.11.2.2 In residential areas, the use of less formal shapes may be acceptable, although the shape must still contain the basic standard turning area dimensions. Turning areas **must** be able to accommodate refuse collection vehicles, with the Council currently using vehicles that are 2.5 metres wide (excluding wing mirrors) and 8.6 metres long.

As an alternative a swept path analysis may be used to demonstrate that the specified service vehicle can be accommodated.

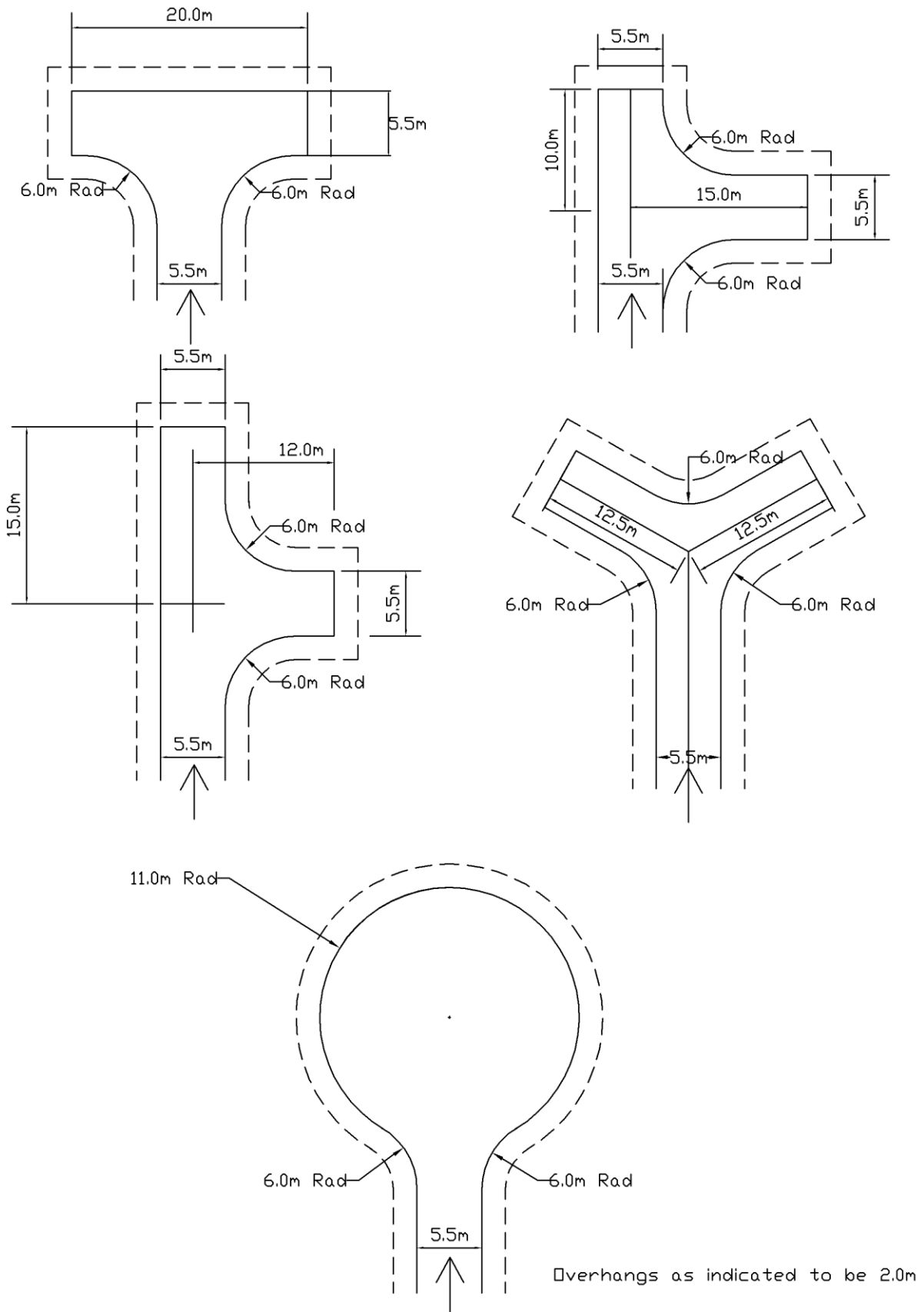

Figure 5.7 Standard Turning Areas for Residential Streets

5.11.3 ***Industrial Turning Areas***

- 5.11.3.1 The industrial turning area is for use within both industrial and commercial areas. Various layout options are shown in Figure 5.8. It should be noted that due to the large size of turning area required and associated difficulty in turning large vehicles, it is recommended that service/access roads in commercial and industrial areas are formed as loops, where possible.
- 5.11.3.2 A separate turning area may not always be necessary where an industrial access road is flanked by service areas that will accommodate the turning manoeuvres of the largest vehicles anticipated.

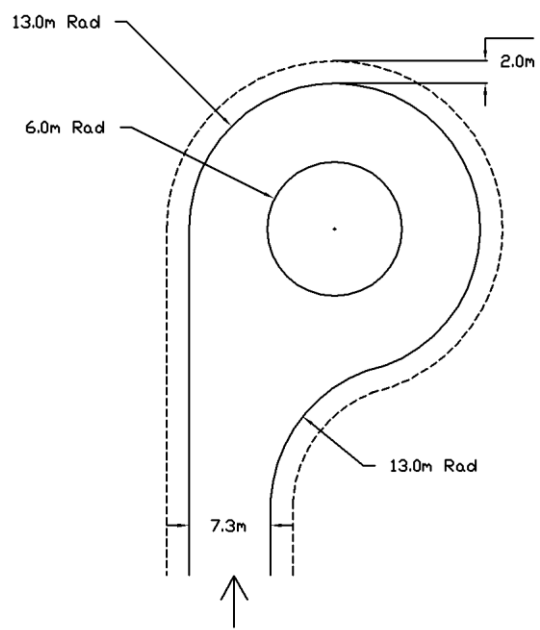
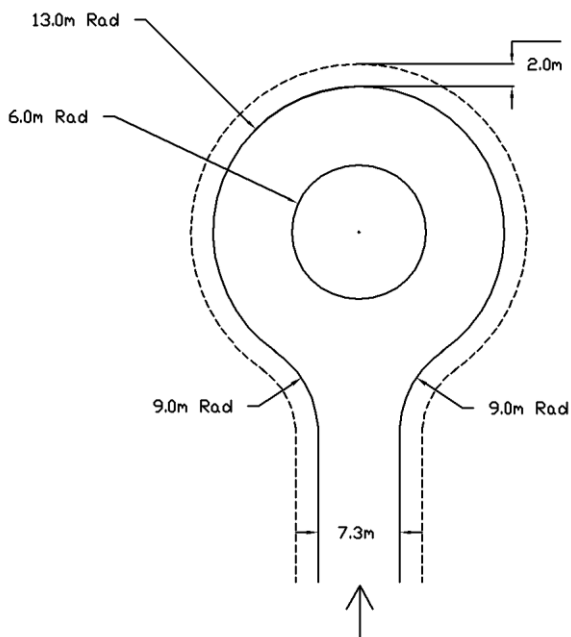
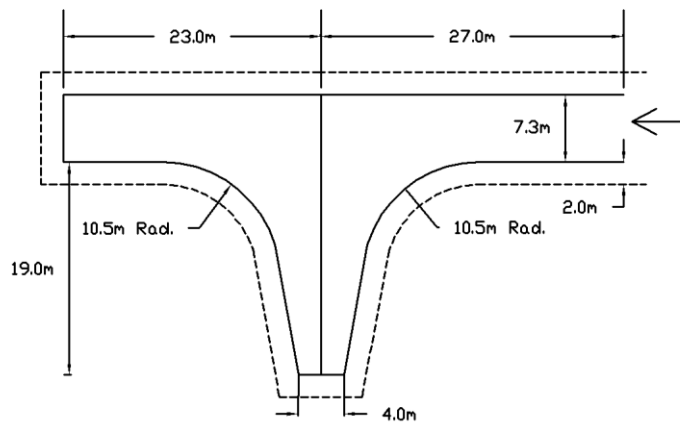
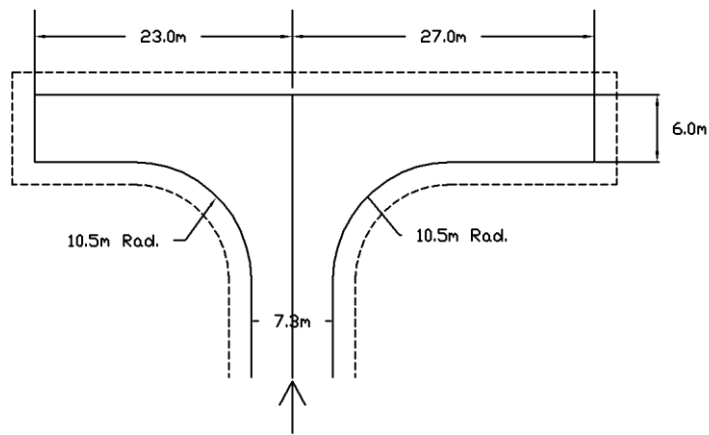

Figure 5.8 Standard Turning Areas for Industrial Areas

5.11.4 **Bus Turning Areas**

5.11.4.1 The turning requirements for buses shall be based on the standards for industrial turning areas. On a public road, the presumption shall be that a turning circle shall be provided where there is no through route.

5.11.4.2 If a bus stop is proposed within the turning circle, a section of straight kerb and footway shall be provided. If it is intended that the turning circle is to serve as a bus terminus, then the carriageway area should be enlarged, to allow one bus to pass a stationary one and turn.

5.12 **Rural Accesses / Slighean-inntrigidh Dùthchail**

5.12.1 For a rural access, a service bay is to be provided. On a narrow road, the service bay could also serve as a passing place. Details of dimensions, construction standards and materials are given in [the Access to Single Houses and Small Housing Developments Guidance](#) (Appendix 10).

5.13 **Private Accesses and Driveways / Slighean-inntrigidh Priobhaideach**

5.13.1 **Introduction**

5.13.1.1 Private accesses and driveways should be able to accommodate the numbers and types of vehicles using them. They may also need to be enhanced for pedestrians and cyclists.

5.13.2 **Private Accesses for Non-Residential Developments**

5.13.2.1 For non-residential developments, including commercial, industrial, leisure and agricultural, the volume of traffic and/or the number of service vehicles entering and exiting the site may result in the need for the private access to be constructed to Industrial Access Road standards, with a carriageway junction formed with the public road. Where required, the access should be kerbed with the public footway having dropped kerbs to help pedestrians cross the access. Gates, if provided, shall be set back a minimum of 15 metres from the nearside carriageway edge and open away from the carriageway only.

5.13.2.2 Where the traffic flow is sufficiently high, the vehicular access should be treated in a similar manner to an uncontrolled crossing at a side road and tactile paving should be provided. A traffic calming measure in the form of a ramped table should also be provided within the entrance highlighting to vehicles that this is a footway crossing. Where the existing crossover surface is being replaced with another surface, it is helpful if the replacement surface provides a contrast in colour and tone with the footway.

5.13.2.3 Pedestrians and cyclists should be provided with a separate access, in order to reduce potential conflict. In addition, segregation of service and customer vehicles should also be provided, especially where a development generates high numbers of each type of trip.

5.13.3 Access for Forestry Extraction

5.13.3.1 Planning consent may be required for any new or improved access to a public road. Developers should contact the Planning and Development Service to confirm planning requirements; **however, for any works connecting to a public road, a Road Opening Permit must be obtained from the appropriate Area Roads and Community Works Manager.** For forestry extraction purposes, specific measures will be necessary in order to maintain road safety and protect the structure of the public road. Full details are available in the TEC Services Technical Advice Note, Forestry Extraction, which is reproduced in Appendix 11 of these guidelines.

5.13.4 Private Accesses and Driveways for Residential Dwellings

5.13.4.1 Where a number of dwellings or private residential parking areas are served by a private access, their design will be influenced by servicing arrangements and number of parking spaces. If the number of vehicles using the access is likely to be low and no service vehicle will enter, then a dropped kerb footway crossing should be sufficient. However, if service vehicles will use the access or there are significant numbers of vehicles, then a kerbed carriageway access should be provided, with its construction appropriate to the level of traffic and its type. Access arrangements should be discussed and agreed with the Council.

| |
|--|
| <p>Design Requirements</p> <p>Access to individual dwellings over kerbed footways shall be by means of dropped kerbs and transitions. At least the first 6 metres of the driveway shall be surfaced with non-loose material, in order to prevent stones and chippings being dragged onto the public road and if gates are provided, these must open inwards and not cross the footway.</p> <p>For rural areas and also those urban roads with high traffic flows having direct frontage, turning space must be provided within the curtilage of the dwelling, to enable a vehicle to enter and exit in forward gear.</p> <p>Private access gradients should not exceed 5% for the first five metres of the access and gradients exceeding 10% thereafter will not normally be acceptable.</p> |
|--|

5.13.4.2 For developments with direct frontage onto lightly trafficked urban roads, it is desirable, but not essential, that curtilage turning space be provided, in the interest of road safety.

5.13.4.3 Drainage of surface water needs to be considered, together with the access requirements for disabled persons.

5.13.4.4 Residents of dwellings served by a shared private access will be responsible for all aspects of its upkeep and maintenance. The developer must ensure that prospective residents are made aware of this obligation.

5.14 Designing Roads For Low Speeds / A' Dealbhadh Rathaidean airson Astaran Ìseal

5.14.1 *Introduction*

5.14.1.1 The layout of a development will be influenced by a range of factors, including the desire to restrict traffic speeds and improve road safety for all road users. Reduction in vehicle speed is in line with the Council's objective of improving road safety. Lower speeds tend to result in a reduction in the number of traffic accidents occurring and their severity. Lower speeds can also make areas generally more pedestrian friendly and reduce traffic noise, which is of benefit in residential areas.

5.14.1.2 As reduced vehicular speeds tend to result in more attractive conditions for pedestrians and cyclists, people can be encouraged to walk or cycle within a particular area, sometimes instead of using the car. More pleasant places and environments that do not focus on the private car are also provided.

5.14.2 *Design*

5.14.2.1 New developments should be designed such that the layouts of new roads, especially within residential areas, physically restrict vehicular speeds but without the need for standard traffic calming features that look as if they are additional to the general road layout and tend to emphasise the street as mainly being for vehicular traffic. The exception to this is the use of raised carriageways at junctions with residential areas, as they can assist pedestrians when crossing a road. Generally, horizontal geometry changes, shared surfaces and use of particular materials would be more effective in delivering a more natural looking traffic calmed area as an integral part of the streetscape. The Council should be consulted about such proposals early during the planning stage. The needs of pedestrians and cyclists must be taken into account and incorporated into the road design.

5.14.3 *Speed Limits*

5.14.3.1 In the interests of road safety and also to create more attractive places, the Council will require all new residential streets, especially those roads that have significant levels of direct residential frontages, to be designed in such a manner that they are suitable for implementation of a 20mph speed limit or zone. Where a Local Distributor Road also has direct frontage access, the appropriate speed limit shall be agreed with the Council during the design stage.

5.14.3.2 Where possible, the speed limit shall be self enforcing and this is likely to require design features to be incorporated in the layout, which seek to ensure the majority of vehicles travel within the speed limit. Reductions in forward visibility and carriageway width are the most effective methods in reducing driving speeds. To meet the statutory requirements for a mandatory 20mph limit or zone, careful design will be required. Where considered necessary, traffic calming features, as discussed in the following sections, may be deemed appropriate. All traffic calming

proposals must comply with the relevant legislation and the developer shall be responsible for ensuring such compliance.

Design Requirements

A gateway feature shall be provided at the beginning of an individual road that has a 20mph speed limit or at the entrance(s) to a 20mph speed restriction zone, in order to highlight the change in speed limit and encourage motorists to adjust their driving accordingly.

5.14.4 Standard Traffic Calming Features

5.14.4.1 There may be occasions where it is appropriate to enhance existing or provide new traffic management or traffic calming measures, mainly in circumstances when such measures need to be provided retrospectively. Where the Council agrees or decides that any traffic management or traffic calming measure should be implemented in order to mitigate the impact of a particular development, the developer will be required to fund the costs for the promotion and construction of these measures. Costs shall include those associated with the processing of any associated Traffic Regulation Order.

5.14.4.2 If distinct traffic calming features are provided, the most common types of traffic calming are horizontal displacements, vertical displacements, road narrowing and surface treatments. In selecting different types, it is important to assess the overall effect of the features selected on the whole development. Features should be selected that restrict vehicle speeds whilst also seeking to protect vulnerable road users, such as pedestrians and cyclists. There may also be a requirement to adopt features that can accommodate buses, preferably without vertical displacement. As a guide, traffic calming features will, on average, require 70-metre spacing to achieve average vehicle speeds of 20mph.

5.14.4.3 There are different types of traffic calming features that can be used. Horizontal displacements should change the direction of the travelling vehicle by a minimum of 45° and should preferably re-align the carriageway by a lane width or more. Whilst the displacement can incorporate parking, it shall not rely on the presence of parked vehicles. Long distance forward visibility can be reduced but not the required stopping sight distance. Features include:-

- road bends
- chicanes
- road humps
- speed tables and cushions
- raised junctions
- side entry treatment
- rumble strips
- carriageway narrowing
- road narrowing pinch points
- traffic islands
- surface treatments and road markings
- changes in junction priority

5.14.4.4 Where the Council agrees to the use of traffic calming features with vertical displacements, it is recommended that bypass cycle lanes or tracks are provided, so cyclists can avoid the need to negotiate level changes. In addition, where horizontal displacements are introduced, the default situation should be that the layout incorporates a cycle bypass or some other alternative arrangement so cyclists can avoid the change.

5.14.4.5 Traffic calming features must be designed, signed and illuminated in accordance with the following current legislation:-

- **The Roads (Traffic Calming) (Scotland) Regulations 1994**
- **The Road Humps (Scotland) Regulations 1998**
- **The Road Humps and Traffic Calming (Scotland) Amendment Regulations 1999 and 2002**
- **ETLLD Circular 1/2006 – Setting Local Speed Limits.**

5.14.4.6 Further guidance on traffic calming design can be found in other documents, such as the IHT publication **Traffic Calming Techniques**, Transport Scotland's **Cycling by Design**, the DfT publication **Local Transport Note 02/08 – Cycling Infrastructure Design** and various relevant **Traffic Advisory Leaflets**.

5.14.4.7 In certain circumstances, it may also be necessary for additional traffic management and/or calming measures to be provided on roads outside the development site. This could apply to commercial and industrial developments as well as residential ones. Such measures must be agreed with the Council.

5.14.5 **Consultation**

5.14.5.1 It is essential that early consultation and discussions take place with the Council, during the planning application stage, to agree which traffic calming features are the most appropriate. In addition, if traffic calming is to be introduced on an existing public road, there may be a need to consult with the local community and any such requirements shall be clarified with the Council.

Pedestrians, Cyclists and Equestrians / Coisichean, Luchd-baidhsagail is Marcaichean

5.15 Pedestrians / Coisichean

5.15 Pedestrians

5.15.1 Introduction

5.15.1.1 Section 4.4 has already highlighted the Council considers walking as an important sustainable mode of travel that shall be encouraged and designed for in any new development. A key aspect of the layout will, therefore, be the provision of a network of high quality pedestrian routes that encourage walking as the preferred mode of travel for most short trips.

5.15.1.2 External and internal features that will generate or attract pedestrian movements should be identified at an early stage in the planning application process and, for larger developments, must be considered in the Transport Assessment and this may include improvements to the existing pedestrian network. These features will establish the main pedestrian routes, which should then be designed to be as direct as possible. Levels of use will influence widths and segregation desirability. Provision for cyclists should be considered at the same time, as often facilities for both modes can be combined and shared.

5.15.2 General Design Aspects

5.15.2.1 Pedestrian routes should:-

- be as direct as possible, whilst having regard for personal safety;
- provide good levels of visibility, ensuring natural surveillance from adjacent buildings as far as practicable;
- avoid the creation of “blind” spots that would need enhanced surveillance measures;
- avoid having main pedestrian routes adjacent to those Distributor Roads that do not have direct frontage access.

5.15.2.2 Where a Local Distributor Road has the dual role of a mixed-use “High Street”, the provision of adjacent pedestrian routes is important, in terms of enhancing the vitality and atmosphere of the area.

5.15.2.3 Special consideration should be given to potential locations of developments likely to be generators of significant levels of pedestrian movement, such as shops, schools, health clinics and leisure facilities, with thought given to what pedestrian routes and crossing facilities may be needed and their appropriate siting.

5.15.2.4 In non-residential developments, it is highly desirable that pedestrian routeings should avoid the need to cross car parks to reach the main entrance of any building. For all types of

developments, direct and safe routes and crossings to bus stops and nearby facilities, such as schools and healthcare centres, should also be provided.

5.15.2.5 Whilst footways are contiguous with a carriageway and their standards normally included as part of the appropriate road description, footpaths are remote from the carriageway. Whilst footpaths have a role to play, they will only be considered for adoption where they form part of the general pedestrian network connecting public roads with each other or providing access to public destinations or areas. Footpaths should be as direct as possible and wide enough to accommodate the anticipated levels of pedestrian activity, including future phases of a development. The width should allow people to stop and talk to each other without causing an obstruction. In addition, it is likely that many footpaths will also be used by cyclists and, therefore, their widths should be increased to accommodate shared use, with **a minimum width of 3.0 metres** required, in order to provide access for maintenance vehicles. A footpath shall be designed so that its entire length is accessible by wheeled maintenance vehicles and plant.

5.15.2.6 Routes of footpaths should be designed in conjunction with public transport provision in order to facilitate convenient access to public transport services.

5.15.2.7 Urban footpaths should normally be provided with street lighting. In some circumstances, it may be desirable for a rural footpath to have some lighting but this must be agreed with the Council.

5.15.2.8 Where a footpath is not adopted by the Council, its future maintenance regime must be clarified and agreed with the Council during the planning process, taking account of its Open Space Policy requirements.

5.15.2.9 Where footways and footpaths link to cycle tracks, special attention shall be given to those areas where pedestrians and cyclists converge.

5.15.2.10 The design of pedestrian facilities shall take account of the requirements for accessibility, as set out in the **DDA** and the associated Code of Practice. In addition, recommendations contained within **“Inclusive Mobility”** and **“Disability Discrimination Act - Good Practice Guide for Roads”** should be taken into account.

5.15.3 ***Pedestrian Crossing Facilities***

5.15.3.1 Where possible, pedestrian routes, especially main ones, should seek to have the minimum number of road crossings but it is unlikely that the design can eliminate all such crossings. Particular attention should be given to the locations at which pedestrians will cross a carriageway, so their exposure to risk is reduced. Whilst the aim is to provide crossing points as close as possible to the pedestrian desire line, this is not always appropriate. In such cases, the use of hard and soft landscaping, as well as street furniture, can guide pedestrians to more suitable locations and help prevent children walking or running directly onto the road.

5.15.3.2 *Major/Minor Priority Junctions* - it is important to take account of the specific requirements of road users. The high speed nature of rural roads is such that specific facilities may be required at some locations in order to ensure the safe passage of specific road users through the junction. This can be equally true at some urban sites where junctions may be used intensively by all types of road user and where the main roads are carrying high volumes of fast-moving traffic.

5.15.3.3 **DMRB TD42** highlights that defined at-grade pedestrian crossing points on the minor road should be a minimum of 15 metres back from the "Give Way" line, and should be sited so as to reduce to a minimum the width to be crossed by pedestrians provided they do not involve excessive detours from their desired paths. Central refuges should be used wherever possible, but not on major roads in a rural situation. Refuges should be at least 1.5m wide to protect wheelchair users and parents with push-chairs when crossing the road. Where pedestrians are expected to cross the minor arm of a junction, tactile surfaces and dropped kerbs should be provided. Such a layout is appropriate for the primary categories of road, such as Strategic Routes, Main Distributors, Regional Routes, Local Distributors (excluding High Streets) and Sub-regional Routes.

5.15.3.4 For secondary category roads, especially residential streets, setting the pedestrian crossing back from the main road is rarely practical or necessary. Where traffic volumes are not high or where vehicle speeds are low, the pedestrian crossing can be positioned closer to the mouth of the junction, which is likely to reflect the natural pedestrian desire line. Guidance on acceptable layouts for such crossings is set out in **Designing Streets**. Alternatively, a speed table can be designed in accordance with current legislation.

5.15.3.5 The requirements of pedestrians should be carefully considered in the design and choice of major/minor priority junctions. It is recommended that the proposed general principles to be applied are agreed with the Council at an early stage.

5.15.3.6 Where an uncontrolled crossing is provided on the minor arm of a junction, it must include the appropriate use of tactile blister paving, dropped kerbs and a central refuge where carriageway widths allow.

5.15.3.7 *Alternative crossing facilities at major/minor junctions* - the following alternative facilities should also be considered for higher trafficked situations, but must be discussed with the Council:-

- Displaced controlled pedestrian crossing
- Subway or footbridge

5.15.3.8 *Roundabouts* - separate pedestrian routes with crossings away from the flared entries to roundabouts are preferable where road widths are reduced and traffic movements are more predictable. Roundabouts by their nature cater for higher traffic volumes and can be particularly difficult to negotiate by pedestrians, particularly those with mobility impairments. For this reason, uncontrolled crossings at roundabouts are not recommended and an alternative crossing facility should be considered.

5.15.3.9 *Alternative crossing facilities at roundabouts* - the following facilities should be considered at roundabouts but must be discussed with the Council:-

- Displaced controlled pedestrian crossing;
- Signalisation of the roundabout, with pedestrian facilities;
- Subway or footbridge

5.15.3.10 *Controlled Pedestrian Crossings* – where grade separation cannot be justified or provided, it may be necessary to consider balancing the needs of pedestrians and vehicles by providing a controlled pedestrian crossing, such as a puffin crossing or a pedestrian stage within a set of traffic signals. The design of controlled crossings is subject to various Pedestrian Crossing Regulations, depending on the type of facility.

5.15.3.11 The design of pedestrian crossings should take account of guidance and recommendations set out in **DMRB TA68**, together with the DfT **Local Transport Notes 1/95** and **2/95**. Signal controlled pedestrian crossings are the safest places for vulnerable pedestrians to cross the road, especially for visually impaired people. In addition, illumination levels on pedestrian crossings should be carefully considered, which will impact on the street lighting design.

5.15.3.12 When providing new or replacing existing controlled pedestrian crossings, audible signals and tactile rotating cones should be provided, in addition to visual signals. These features should also be provided on the controls for the pedestrian phase at junctions. Where it is not practical to provide audible signals, such as where two crossings are close together, tactile rotating cones should always be provided. The pole the crossing controls are fixed to should ideally be located on the right of the crossing in the direction of travel, since guide dog users are generally trained to use a guide dog in their left hand. Puffin crossings have a number of advantages for pedestrians over the older pelican type crossing including an infrared detector which senses when pedestrians are using the crossing and holds the signals for drivers at red. Ideally all new installations should be puffin crossings. **Inclusive Mobility** contains detailed advice on the design of crossings.

5.15.3.13 A tactile surface must be provided on the footway approaches to all controlled crossings, as shown in Figure 5.9. Tactile paving is used by visually impaired pedestrians to align themselves on the crossing and the paving laid correctly to guide users to the dropped kerbs on the opposite side of the road. Detailed guidance is provided in the Department for Transport document **Guidance on the Use of Tactile Paving Surfaces**. In addition, there may be a requirement for a high skid resistant surfacing material to be used on the carriageway approaches to a controlled crossing and advice should be sought from the Council.

Design Requirements

Dropped kerbs are required at all pedestrian crossings (whether controlled or not) to assist wheelchair users and parents with prams, as shown in Figures 5.10a and 5.10b.

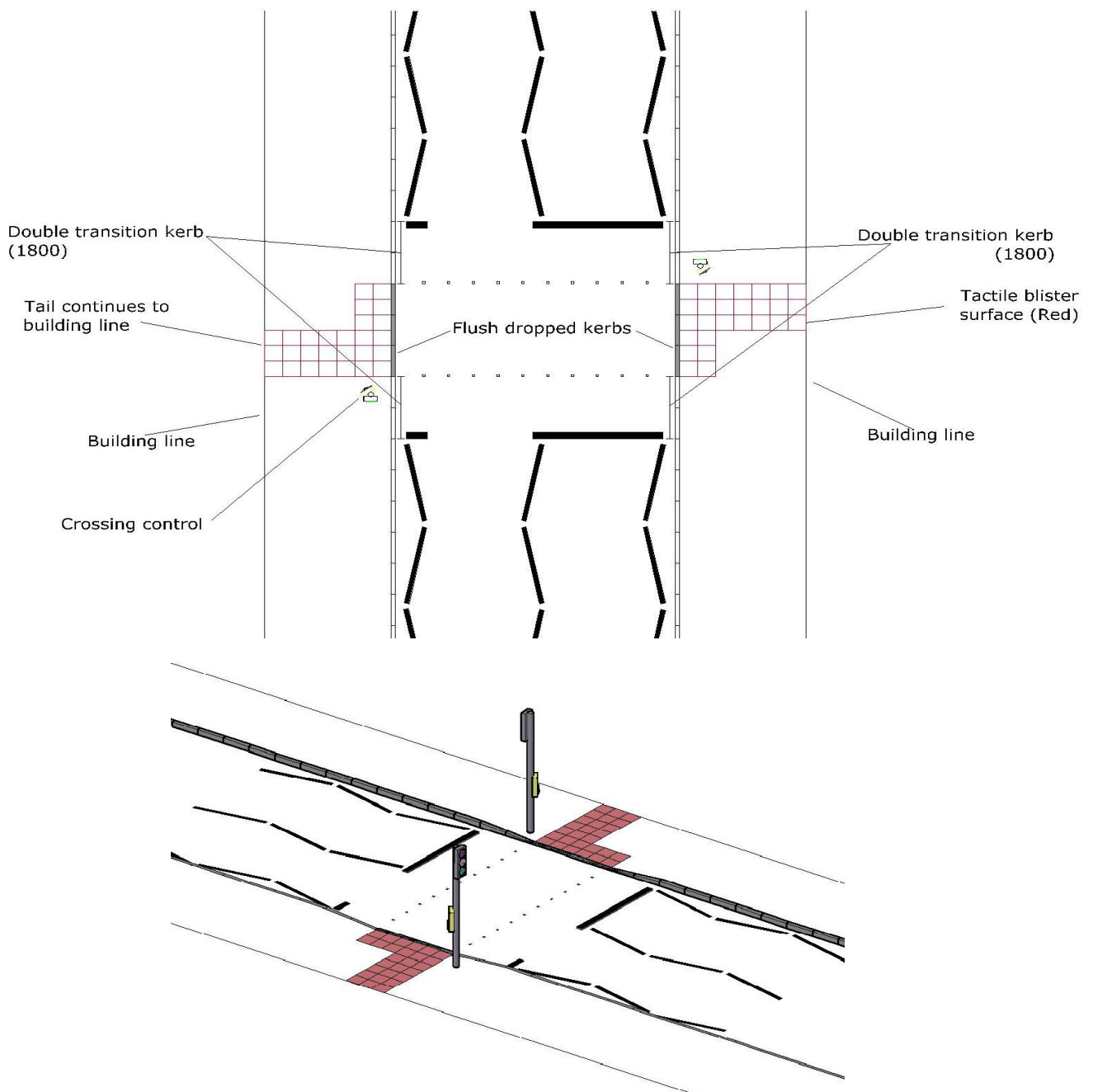

Figure 5.9 Controlled pedestrian crossing arrangement

5.15.3.14 At pedestrian crossing points, dropped kerbs should be installed to allow disabled people to cross the road, laid to the tolerances recommended in **Inclusive Mobility**, ideally using rounded bullnose kerb. Generally, all new crossing installations should be flush with the carriageway, however for maintenance purposes the dropped kerbs should not be greater than a 6-millimetre maximum upstand tolerance.

5.15.3.15 The following dropped kerb issues are common problems on many existing roads:-

- The upstand at most dropped kerbs is higher than the 6 millimetres tolerance, thus creating a significant barrier for mobility impaired users.
- Road drainage at locations of dropped kerbs can be a significant issue that may require special attention.
- It is apparent that the use of single transition kerbs at crossings is common practice and thus the localised longitudinal fall of a footway at the crossing could be in excess of the maximum gradient recommended in **Inclusive Mobility** of 9 per cent (1 in 11) in extreme circumstances.

Design Requirements

All new dropped kerbs at crossing installations should be dropped over two transition kerb lengths at either end, wherever practical, to achieve the required gradients.

5.15.3.16 *At Grade Crossings* - at pedestrian crossing points, other than those at which a suitable grade-separated facility is provided, sections of kerbs must be lowered to permit easy access. In some circumstances, such as within residential areas, the use of raised carriageways would be a suitable alternative method. Tactile paving should be used at all crossing points.

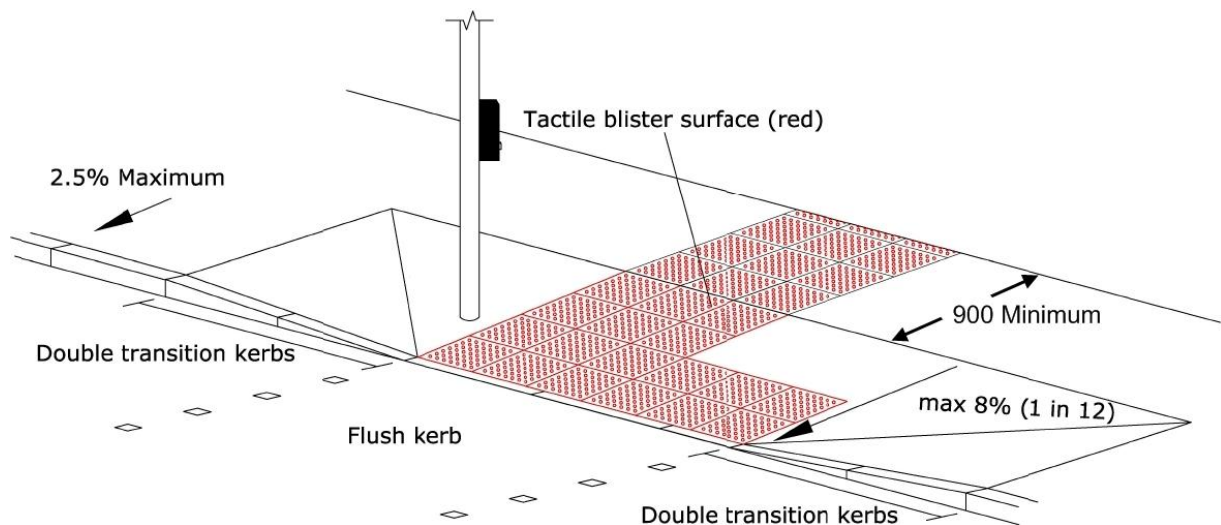

Figure 5.10a Flush dropped kerbs at a controlled pedestrian crossing

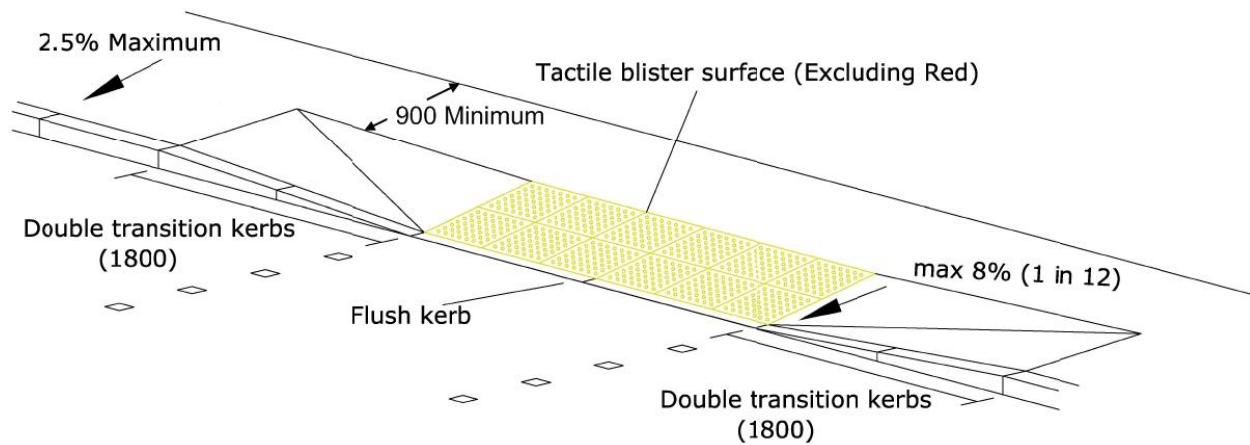

Figure 5.10b Flush dropped kerbs at an uncontrolled pedestrian crossing

5.15.3.17 *Grade-Separated Crossings* – where both pedestrian and vehicular traffic levels are very high or where they offer the only practicable means of providing a desirable link across a highly trafficked road, it may be appropriate to consider the provision of footbridges and underpasses, as the form of carriageway crossing. Where deemed suitable, the facility should be designed to be convenient, pleasant and safe to use, with the route being more appealing than any alternative. This may involve lifting or lowering the carriageway level in order to ensure that the pedestrian route has minimal change in level. Underpasses have particular problems, with regard to perceived personal safety, and, therefore, should be avoided where possible.

5.15.4 **Additional Design Considerations for Pedestrians**

5.15.4.1 *Routes for prams and wheelchairs* - the design of the layout must ensure that all pedestrian routes are suitable for persons using prams and wheelchairs, particularly those routes from residential areas to shops and community facilities. Steps, steep crossfalls/gradients, gratings likely to trap wheels and walking sticks, and street furniture obstructions should be avoided.

5.15.4.2 *Pedestrian Guardrails* – there is a general presumption against controlling pedestrians by use of guardrails. However, some exceptions to this presumption will be accepted, where justified, such as at schools or other locations where there are significant numbers of children. Where guardrails are used, they must be of a high-visibility type, which permits drivers to clearly see pedestrians, such as wheelchair users, children and people of short stature who can be obscured by the railings.

5.15.4.3 In most circumstances, guardrails are not specifically an accessibility feature and railings can be a hindrance to disabled people. The rails can narrow the pedestrian route and can present a hazard to mobility impaired people. For these reasons:-

- there should be at least 1200 millimetres between parallel guardrails;
- guardrails should be at least 1000 millimetres and ideally 1200 millimetres above ground level;
- guardrails should extend to within at least 200 millimetres of the ground or have a kick board provided, to assist visually impaired people to detect this feature; and
- there should be a minimum 450 millimetres offset from the carriageway.

5.15.4.4 It is recommended that guardrails should contrast in tone with their surroundings but provided guardrails are sited appropriately only the ends of the guardrailing need be highlighted where they project into the pedestrian flow, by provision of two 150 millimetre deep bands that contrast tonally with the colour of the railing.

5.15.4.5 Further advice on the use of pedestrian guardrail is provided in the DfT publication **Local Transport Note 2/09 – Pedestrian Guardrailing**.

5.15.4.6 *Routes on Local Distributor Roads* – where pedestrian routes run adjacent to Local Distributor Roads with high traffic flows, it is desirable that they should be separated from the carriageway by a verge, in the interests of road safety, unless agreed otherwise with the Council. Verges need not necessarily be required to have a grass surface. The requirement for a verge would not normally apply where the road has the role of a traditional High Street.

5.15.4.7 *Vehicular Footway Crossings* – where vehicular access is to be taken across a footway, the ramped part shall be restricted to the front section of the footway, adjacent to the carriageway, in order to enforce the priority of pedestrians over vehicles. Having a short section of ramp will also encourage lower speeds for those vehicles crossing the footway. There is a general presumption against the use of kerbed service roads in those areas of high pedestrian flows and within urban centres.

5.15.4.8 *Gradients* – it is desirable that the gradients on footways and footpaths do not exceed 5%, on average, with a normal local maximum of 8% acceptable, although it is recognised that a footway gradient will relate to the adjacent carriageway gradient. In certain circumstances, a steeper footpath gradient may be permitted, except on those routes delineated for pedestrians with prams and wheelchairs, subject to the requirement that a handrail is provided on at least one side, together with rest platforms, at appropriate spacings. If a steep footway is unavoidable, a handrail may be required and should be provided preferably at the back of the footway.

5.15.4.9 *Ramps and Steps* – pedestrian ramps and steps should be avoided, if possible. However, where provided, they shall comply with the geometric standards and recommendations set out in **Inclusive Mobility**.

5.15.4.10 The developer should be aware that steps will not normally be adopted by the Council. As a result, steps should never be the only pedestrian route provided. However, some people find ramps difficult to negotiate and steps should be provided in addition to ramps.

5.15.4.11 *Pedestrian Barriers* – situations where a main public footpath meets a road at right angles should be avoided, because of the inherent danger of children going onto the road. Where such an arrangement cannot be avoided, the provision of pedestrian guardrail or a staggered pedestrian barrier should be considered, as part of the layout design.

Design Requirements

The design of a pedestrian barrier and its materials shall be approved by the Council and must take account of the need to permit access for maintenance vehicles.

5.15.4.12 *Disabled Access to Buildings* – if disabled access to a building includes the provision of a ramp, this should normally be outwith the public footway. Where this cannot be achieved, the layout must be agreed with the Council. The design shall take account of requirements set out in the Technical Handbooks related to **Building (Scotland) Regulations**. Additional advice is provided in the IHT publication **Guidelines for Reducing Mobility Handicaps**.

5.15.4.13 *Street Furniture/Ancillary Equipment* – there is a wide range of different types of street furniture, from lighting columns and litterbins to bollards and sign poles. Badly sited furniture can be an obstruction to people with mobility difficulties.

5.15.4.14 Badly designed street furniture can also pose a hazard to visually impaired people. Furniture lower than 1.0 metre in height, such as benches without backrests and low bollards, are not in most ambulant adults' normal line of sight. In addition, all street furniture should be detectable at ground level with a long cane. Projecting litterbins fixed to lighting columns and the glazed side walls of cantilevered bus shelters are examples of street furniture which create potential hazards.

5.15.4.15 Visually impaired people who receive mobility training, including guide dog and long cane users are trained to walk in the middle of a footway, since there are normally less obstructions in this zone. Visually impaired people move towards the kerb edge or the back of the footway when looking for a crossing or building entrance respectively.

5.15.4.16 It is recommended that items of street furniture should be grouped together where possible to assist visually impaired people to identify the potential hazard. Colour, including the use of coloured banding, can be used to help avoid collisions with street furniture.

5.15.4.17 The design of places should, therefore, ensure that all necessary street furniture be at least 1.0 metre high and be grouped together at the back of the footway where possible and out of the main pedestrian flow. Street furniture that is in or close to the pedestrian flow, particularly freestanding furniture, should contrast tonally with its surroundings.

5.15.4.18 *Visual Colour* - for visually impaired pedestrians relying on residual vision, it is essential to ensure that the colours of street furniture contrast with their surroundings. Colours which appear to be different from one another in colour (chroma) can be very similar tonally (e.g. green and brown) and, therefore, do not give sufficient contrast. Contrast is the visual perception of one element when viewed against another and is indicated by the difference in light reflectance between two surfaces. It is generally recognised that 30 points of difference in light reflectance between surfaces should give adequate contrast to be noticeable to a large proportion of partially sighted people.

5.15.4.19 When specifying suitable colours for new schemes, designers should establish the light reflectance value of the street furniture with manufacturers. For further information on the use of colour reference should be made to '**Colour, contrast and perception - Design guidance for internal built environments, 2004**', published by Reading University, as well as **BS8300 Design of Buildings**.

5.15.4.20 In the design of new schemes or for the installation of new items of street furniture, tonal contrast must be a key element of the aesthetic design of materials and finishes.

5.15.4.21 Ideally, existing street furniture should also provide sufficient tonal contrast and, in some cases the Council may require the retrospective application of a tonally contrasting treatment to be applied to such street furniture.

5.15.4.22 *Seating* - many disabled people cannot walk for more than 50 metres before taking a rest and suitable seating at regular intervals is a particularly important feature in a high quality pedestrian environment. The design of seating should consider the following:-

- Seats with backrests should be provided at regular intervals along well used pedestrian routes;
- Seating should generally be 450 – 480mm high, a height most people can rise from;
- At bus stops and other locations where people wait for a short period of time 'perch' seats can be provided. A height of 580mm is recommended for this type of seating;
- At least a proportion of seating in a group should be fitted with armrests to assist in rising from the seat;
- To allow wheelchair users to transfer on to fixed seating, not all seats should have armrests, i.e. there should be no armrest on the end of a row of seats; and
- A space should be kept clear next to fixed seating to accommodate wheelchair users.

5.15.4.23 *Signage* - the specification of traffic signs for road users is explained within the **Traffic Signs Manual (TSM)** and the **Traffic Signs Regulations and General Directions 2002 (TSRGD)** *which is due to be replaced in 2010*. **Inclusive Mobility** contains more information on the design of signage for pedestrians and this is based on **The Sign Design Guide**, a publication produced by the Sign Design Society and which explains the principles of clear signage, including the use of colour to highlight the sign from its background, to highlight the text on the sign and the need for upper and lower case lettering rather than all capitals.

5.15.4.24 Only around 5% of visually impaired people have no sight at all and the vast majority have some residual vision and may be able to distinguish colours, or shades of light and dark. By making a sign clear and easy to read for a visually impaired person it will make the sign clear and easy to read for everybody.

5.15.4.25 Sign poles and cantilevered signs can present a barrier and a hazard to mobility impaired people and application of minimum footway widths should be included in the design process. The lack of the minimum distance between poles on double pole signs and the lack of colour contrast to highlight sign poles can create problems.

5.15.4.26 Where signage aimed at pedestrians is not covered by **TSM/TSRGD**, signage should follow the guidance in **Inclusive Mobility** and the **Sign Design Guide**. Authorisation will be required for non-prescribed signs and this must be discussed with the Council.

5.15.4.27 *Lighting* - **BS5489** is the Code of Practice for Road Lighting. The illumination of the pedestrian environment is often neglected and **Inclusive Mobility** describes the recommendations of the British Standard and includes a table of light levels for different types of area. All new and replacement lighting schemes for pedestrian areas should meet the criteria described in **Inclusive Mobility** in addition to **BS 5489**.

5.15.4.28 Lighting columns can obstruct the footway and present a hazard to visually impaired people. Therefore, the columns should be located at the back of the footway where possible. In existing locations, columns should be sited consistently either at the back or front of the footway.

5.15.4.29 *Grit Bins* – in those developments where pedestrian routes have gradients steeper than 8% and/or there is an extensive network of footpaths, the Council may require grit bins to be provided, with small areas of hard standing formed for the siting of the bins, **adjacent** to the footways/footpaths.

5.15.5 **Footway Widths Adjacent to Carriageways**

5.15.5.1 Table 5.8 specifies the required minimum widths of footways, ie, those pedestrian routes adjacent to carriageways. These widths may require to be increased at those locations where high levels of pedestrian flow are expected. Relaxations in footway widths are at the Council's discretion.

Design Requirements

Where vehicles park at right angles to a footway, an additional 0.8 metres shall be required to accommodate any vehicle overhang.

Table 5.8 Minimum Footway widths

| Frontage Development | Width (metres) ¹ |
|-------------------------|-----------------------------|
| None | 2.0 ² |
| Industrial | 2.0 ² |
| Residential | 2.0 ² |
| Schools and Local Shops | 4.0 |
| Major Shops | 5.0 |
| Rural Roads | 2.0 ³ |

Note 1 - additional 0.8 metres required if adjacent right angled parking provided.

Note 2 - minimum 3.0 metre shared footway/cycle track for main and local distributor roads, excluding High Streets.

Note 3 - 1.0 metre separation strip, preferably grassed, to be provided between footway and carriageway.

5.15.5.2 Where a shared footway/cycle track runs adjacent to a Main or Local Distributor Road (excluding High Streets), it is desirable to separate it from the carriageway by a verge, which would normally be 2.0 metres wide.

Design Requirements

If a Distributor Road verge is not provided or is located to the rear of the shared footway/cycle track, then the first 0.6 metres of the shared facility, adjacent to the carriageway, shall be constructed in block paving, to encourage segregation.

5.15.6 Footpath Widths Remote from Roads

5.15.6.1 Table 5.9 specifies the required minimum widths of footpaths and pedestrian areas, which are remote from the road network and are intended for adoption. The widths may require to be increased to allow for maintenance of the footpath and/or underlying services. In most cases, the footpath will be a shared footpath/cycle track facility. Relaxations in widths are at the Council's discretion.

Table 5.9 Minimum Footpath widths

| Type of Footpath | Width (metres) |
|------------------------------|--------------------|
| Pedestrian and Shared Routes | 3.0 ¹ |
| Shopping Precinct | 6.0 |
| Footbridge | 2.5 ^{2 3} |
| Underpass (2.4m headroom) | 2.5 ^{2 3} |
| Rural locations | To be agreed |

Note 1 – wherever possible, all paths are to be designed to shared footpath/cycle track standards.

Note 2 - may be inadequate for maintenance purposes.

Note 3 - widen to 4.0 metres if shared with cyclists, with height of underpass increased to desirable minimum of 2.7 metres to accommodate for cyclists.

5.15.6.2 Where possible, the footpath should be located within a wider area of open space, having adjacent verges. Where landscaping is provided, consideration must be given to future maintenance requirements, with the objective of limiting the need to have to regularly trim back any over-hanging vegetation.

5.16 Cyclists / Luchd-baidhsagail

5.16.1 Introduction

5.16.1.1 In order to maximise the opportunities for cycling, it is important that a high quality cycle route network is provided. This is consistent with the Street User Design Hierarchy described in Section 4.3.4.4, the Council's transport policies and also with national policy.

5.16.1.2 All new developments must consider the access needs of the people using the development and should provide facilities that will allow them to make trips by bicycle. This should include routes both within and adjacent to new developments. This may include the enhancement or extension of existing nearby cycle facilities, which should be linked to new developments, as well as new routes.

5.16.1.3 A cycle network accommodating all forms of daily trips made by people accessing the development should be provided. The network should link residential areas to key locations, such as shops, schools, bus routes, health clinics, major employment and parks, etc. Early consultation with the Council is essential, in terms of agreeing the cycle network, any new facilities and their requirements or alterations to the existing network.

5.16.1.4 It is important that residential schemes and other developments are highly accessible for cyclists, with links being visually attractive. The cycle network is likely to consist of different forms of links, such as roads with low traffic speeds and volumes, on-road cycle lanes and segregated pedestrian/cycle tracks. In residential areas, where 20mph speed limits are likely to be in place, cyclists and vehicles can usually safely share the same carriageway, although key cycle routes should be as direct as possible. Where culs-de-sac, one-way streets or other movement restrictions are proposed, full permeability of the development should be retained for cyclists and pedestrians.

5.16.1.5 Developers should be aware that when an existing footway or footpath is upgraded to accommodate cyclists a TRO has to be processed for this change of use, with the shared facility marked and signed in accordance with current legislation. The developer would be liable for the costs associated with these requirements. A new shared pedestrian/cycle facility does not require a TRO but must be signed and marked appropriately.

5.16.1.6 Design requirements for cyclists are provided in this Section. Reference should be made to **Cycling by Design**. In addition, further useful guidance is provided in **LTN 02/08 – Cycling Infrastructure Design**.

5.16.2 *Link Design*

5.16.2.1 The design of new cycle facilities should meet the following objectives:-

- Adopt the following cycle design hierarchy - Preference 1 has cyclists sharing with low speed/flows of vehicles on the carriageway; Preference 2 has cyclists using carriageway cycle lanes and Preference 3 has segregation of cyclists;
- New cycle facilities should link key local destinations and existing networks;
- Cyclists should be segregated from high volumes of vehicular traffic, particularly where vehicle speeds are 40mph or higher; and
- Signal-controlled crossing points should be provided for cyclists on those roads with high traffic flows.

5.16.2.2 Cyclists sharing with vehicles on a road will generally only be acceptable when vehicle speeds (ideally, 20mph or lower) and traffic volumes are low.

5.16.2.3 Cycle lanes on the carriageway can be acceptable where the width of carriageway is wide enough to accommodate the cycle lanes, without vehicles having to over-run them. In addition, the cycle lanes should be kept free of parked vehicles wherever possible, either through design or enforcement.

5.16.2.4 Cycle lane provision for cyclists on the carriageway is provided in two ways:-

- *Mandatory Cycle Lane* – defines an area of the carriageway that is reserved for cyclists and requires a TRO to prohibit all vehicles, except pedal cycles, to enter or travel within the cycle lane.
- *Advisory Cycle Lane* – primarily used to warn drivers of the presence of cyclists and encourage them to adopt a line of travel away from the cyclists. It does not require a TRO, therefore has no legal status and, as a result, is often subject to obstruction by parked vehicles. Vehicles are also permitted to drive along the cycle lane, which can cause conflict when overtaking cyclists.

5.16.2.5 In urban areas, it is preferable to highlight the cycle lane or sections of it by use of coloured surfacing. In addition, it is common practice for the Council to permit cyclists to use mandatory bus lanes and this needs to be stated within the associated TRO.

5.16.2.6 The absolute minimum width of a cycle lane should be 1.5 metres. Desirable minimum cycle lane widths are set out in Table 5.10.

Table 5.10 With-flow cycle lane widths

| Standard | Width (metres) | Comment |
|-------------------------|------------------|--|
| Maximum Width | 2.5 ¹ | Lanes of this width should be used where cycle flows are expected to be >150 cycles/peak hour and overtaking cycles within the lane can be expected. |
| Desirable Minimum Width | 2.0 ¹ | The minimum width that should be considered for a cycle lane where cycles overtaking each other is not anticipated to be frequent. |
| Absolute Minimum Width | 1.5 ² | The running width of the lane should be free from obstructions such as debris, gullies and yellow line road markings. |

Note 1 - cycle lanes over 2.0m wide in areas of car parking may attract drivers to park in them. Physical barriers, mandatory lane markings or parking and loading restrictions can prevent this.

Note 2 - lane widths narrower than 1.5m can present a hazard to cyclists and motor vehicle drivers. Only in exceptional circumstances where it is safe to do so and over short distances – for example where stationary traffic blocks the route to an advance stop line and the proposed lane is completely free from obstructions such as gullies - should widths down to 1.2m be considered. Lanes narrower than this should not be provided on a live carriageway.

5.16.2.7 Where car parking is located adjacent to a cycle lane, it is preferable that a buffer strip is provided adjacent to the cycle lane to avoid conflict between car occupants opening doors and cyclists using the cycle lane.

5.16.2.8 Where road space permits, it is desirable to provide a contra-flow cycle lane along a one-way street. In such circumstances, the absolute minimum width should be 1.5 metres (2.0 metres for a two-way cycle lane), if there is sufficient carriageway space.

5.16.2.9 *Cycle tracks* – a cycle track is a route provided for cyclists that can be either part of a road, adjacent to the carriageway, or a separate facility some distance from a road. A cycle track should be located to be free from conflict with parked motor vehicles.

5.16.2.10 Where pedestrians are permitted to use a cycle track, consideration should be given to delineating the facility to separate pedestrians and cyclists or to permit shared use. This decision should be based on site-specific factors such as:-

- bicycle and pedestrian volumes;
- the function of the area;
- use by disabled people; and
- available width.

5.16.2.11 Reference should be made to the advice in **Cycling by Design** in considering whether shared use or delineated facilities are the most appropriate.

5.16.2.12 The widths of cycle tracks should comply with the guidance provided in Table 5.11. However, widths are influenced by the level of cyclist and pedestrian activity and the function of the area, hence widths greater than the minimum specified should be provided wherever possible. Additional clearance from fixed objects should be provided, either in the form of a buffer strip or additional track width, as shown in Table 5.12. Reference should be made to **Cycling by Design** for further guidance.

Table 5.11 Segregated Cycle Track Facility Effective Widths

| Facility | Standard | Width (m) | Comments |
|-------------------------------|-------------------|------------------|---|
| One way cycle track | Desirable Minimum | 2.0 | Operates satisfactorily for flows of up to 150 cycles/ hour with minimal overtaking anticipated |
| | Absolute Minimum | 1.5 | The running width required that is free from obstructions such as debris, gullies, road markings and street furniture |
| Two way cycle track | Desirable Minimum | 3.0 | For high cycle flows of up to 2,500 cycles per hour |
| | Absolute Minimum | 2.0 ¹ | Operates satisfactorily for two-way flows of up to 200 cycles per hour free from obstructions such as debris, gullies, road markings and street furniture |
| Shared use path/ footway | Desirable Minimum | 3.0 | Typically regarded as the minimum acceptable for combined flows of up to 300 per hour |
| | Absolute Minimum | 2.0 ² | Can operate for combined flows of up to 200 per hour but will require cycles and pedestrians to frequently take evasive action to pass each other |
| Pedestrian only path/ footway | Desirable Minimum | 2.0 | The minimum width in normal circumstances to permit passage of two wheelchair users. |
| | Absolute Minimum | 1.5 | Acceptable over short distances in specifically constrained environments, such as at bus stops or where obstacles are unavoidable ¹ . |

Note 1 - track widths narrower than 2.0m can present a hazard to cyclists, however widths as low as 1.5m may be acceptable over short distances where there is no alternative. Cycle tracks of this width should only be considered where two-way flows of less than 150 cycles per hour are likely.

Note 2 - in particularly constrained situations or for combined flows of less than 100 users per hour, a width of 1.5m may be considered. However this will create conflict between users and should only be used over short distances where no alternative is available.

Table 5.12 Clearance Distances to Fixed Objects

| Object | Absolute minimum clearance (m) | Comments |
|--|---------------------------------------|---|
| Low upstand ≤ 50 mm | Nil | |
| Kerb height 50 mm to 150mm | 0.20 | Added to the effective facility width or a separate buffer strip |
| Isolated feature (eg sign post, lamp column) or continuous feature of height <1.2m | 0.25 | Added to the effective facility width or a separate buffer strip |
| Continuous feature of height >1.2m | 0.50 | Added to the effective facility width or a separate buffer strip |
| Carriageway | 0.50 ¹ | Margin (grass verge or buffer strip) between effective cycle track width and a live carriageway |

Note 1 - the desirable minimum separation between a footway or cycle track on roads with a speed limit in excess of 40mph should be 1.5m. A hardstrip can be considered to be part of the separation.

5.16.2.13 It is important a smooth and even riding surface is provided, including those sections of cycle track that cross vehicular access crossing points. Where possible, cycle tracks should meet side roads without a sudden change in level. Raised tables are the preferred method, but where dropped kerbs are used instead, they should be flush with the carriageway, yet designed to avoid drainage problems.

5.16.2.14 A cycle track should not feed cyclists back onto the main carriageway in proximity to a junction, as this can introduce a point of conflict. In addition, careful design will be needed where a cycle track converges onto a footway or footpath.

Design Requirements

Gradients – cycle track gradients should not normally exceed 3%, but with a normal local maximum of 7% acceptable over short lengths. Reference should be made to **Cycling by Design** for full guidance on gradients. The gradient shall be reduced on the approach to a connection with a road.

Crossfall/ Superelevation – for all routes, the minimum crossfall should be 2.5%.

Visibility – a desirable minimum forward visibility distance of 45 metres should be provided, for cyclist comfort, with an absolute minimum stopping distance of 20 metres.

Horizontal curve radius – a desirable minimum horizontal curve radius of 15 metres, with an absolute minimum of 4.0 metres, should be provided.

Vertical clearance – a desirable minimum headroom height of 2.7 metres should be provided, with an absolute minimum of 2.4 metres acceptable over a very short distance.

Surfacing – surfacing for a shared use may be of a standard footway construction, but standard or small element concrete slab paving is not generally suitable for cyclists.

5.16.3 Cycle Facility Road Crossings and Junctions

5.16.3.1 All proposed cycle facility road crossings are to be discussed and agreed with the Council prior to submission of the RCC Application.

5.16.3.2 Whilst cycle routes are likely to require road crossings, their number should be kept to a minimum, wherever possible. The type of crossing facility provided will depend on the volumes of traffic on the road. For example, where a major cycle route crosses a minor access or cul-de-sac, a raised carriageway crossing may be considered. Where a main road cycle lane crosses a minor road junction, the cycle lane should be continued across the mouth of the minor road, as shown in Figure 5.11.

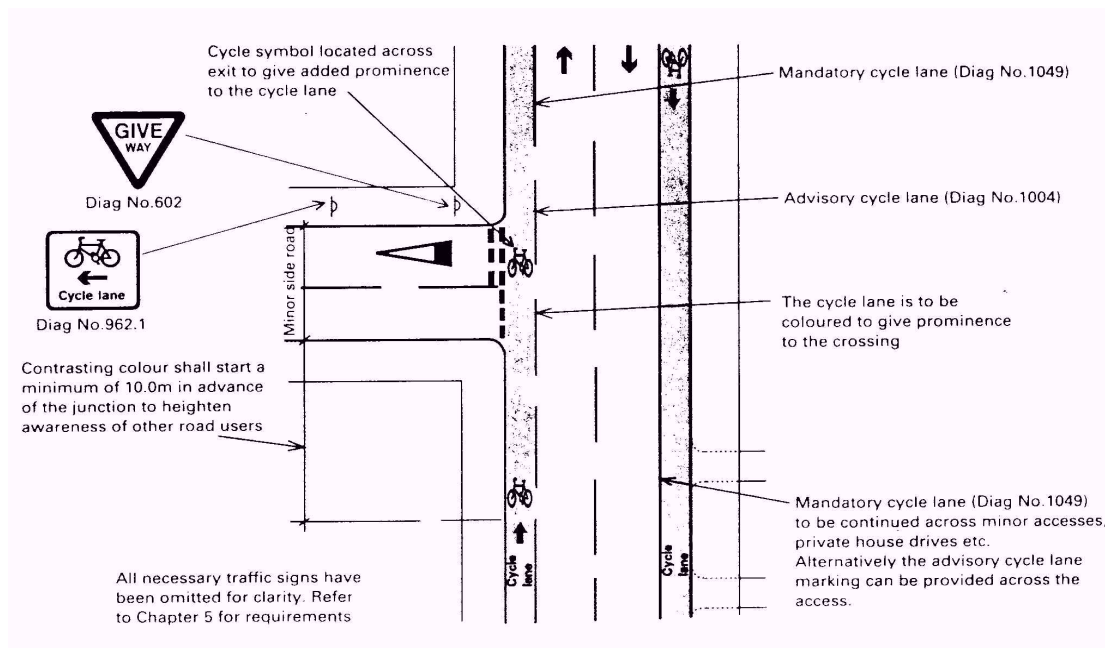

Figure 5.11 Cycle Lane Priority Crossing

5.16.3.3 Where a cycle track crosses a minor road, reference should be made to **Cycling by Design** with regard to advice on suitable crossing arrangements.

Design Requirements
For cycle facility crossing points, the preference is to provide a raised carriageway. Where this is not possible, dropped kerbs must be installed.

5.16.3.4 Where a signal-controlled facility is deemed necessary, a Toucan crossing shall be provided. This is a shared road crossing for both pedestrians and cyclists. Design details for a Toucan crossing are provided in the DfT's **Traffic Advisory Leaflet 10/93 Toucan – An Unsegregated Crossing for Pedestrians and Cyclists**, together with **Local Transport Notes 1/95 The Assessment of Pedestrian Crossings** and **2/95 The Design of Pedestrian Crossings**.

5.16.3.5 Grade separated crossings designed to accommodate pedestrians with mobility difficulties are likely to be suitable for use by cyclists, although there may be a requirement to check that adequate width and headroom is provided. On new bridges, parapets must have a minimum

height of 1.4 metres to accommodate cyclists. For existing bridges with lower parapets, cycle access should be permitted, with the parapet treated as an effective width restriction of up to 0.5m. Further guidance is provided in **Cycling by Design**.

5.16.3.6 *Junctions* – as a significant percentage of injury accidents involving cyclists occur at junctions, it is very important that junctions are carefully designed to take account of the safety of all road users. Detailed guidance on the design of cycle facilities at junctions is contained in **Cycling by Design** and this should be referred to.

5.16.3.7 *Advanced stop lines* – advanced stop line boxes shall be implemented, to allow cyclists to move to the front of waiting vehicles at a signal-controlled junction. This arrangement allows cyclists to move forward in advance of vehicles and be more noticeable to drivers. Advance Stop Lines must be preceded by mandatory or advisory cycle lanes or, in restricted circumstances, by a short 'stub' to indicate a point of entry to cyclists.

5.16.3.8 *Roundabouts* – special care should be taken when considering the provision of a roundabout where cyclists are permitted, as they can often experience difficulty when trying to negotiate the roundabout. If the roundabout is deemed necessary, then it is recommended that cyclists should be routed away from the roundabout, where possible. Hence, the location of a roundabout needs to be carefully considered to ensure that cycle routes are as direct and continuous as possible. The exception would be where there are very low traffic volumes or traffic speeds, as might be expected within minor residential streets.

5.16.4 **Additional Design Issues for Cyclists**

5.16.4.1 *Signage* – the cycle network will require signage to be erected. Early contact with the Council should be made, to discuss and agree the detailed requirements. Signage must be in accordance with the current **TSRGD**.

5.16.4.2 *Traffic calming* – where traffic calming features are proposed in locations that permit cycling, the design of the features should seek to minimise impact on cyclists and reduce potential conflicts with vehicles. General advice on traffic calming is given in Section 5.14.

5.16.4.3 *Lighting* – during the design stage, agreement must be reached with the Council, with regard to the appropriate level of lighting that should be provided for a cycle track. For some facilities, such as in rural locations or leisure routes, lighting may not be required.

5.16.4.4 *Access barriers* – it is generally desirable that cycle routes do not have access controls, which can delay cyclists. However, experience suggests there may be a need for some form of access barrier to be provided at certain locations, in order to prevent use of the route by unauthorised vehicles, especially motorcycles. The design of any barrier needs to take account of access requirements for all users and for maintenance vehicles and should comply with the guidance in **Cycling by Design**.

5.16.4.5 *Personal safety and security* – it should be noted that remote cycle tracks have the potential to be less secure than those facilities on or adjacent to the road network. It is important that the development layout is designed so cycle routes that form part of the core cycle network are overlooked by dwellings, shops and other buildings. Where possible, the routes should be lit and landscaping should avoid obscuring visibility. Measures to provide shelter from wind, which can be a problem for cyclists, should not interfere with natural surveillance.

5.16.4.6 *Cycle parking* – guidance on cycle parking standards and facilities is provided in Chapter 6.

5.17 Provision for Equestrians / **Ullachadh airson Mharcaichean**

5.17.1 Where a development provides facilities for equestrians, horse riders should generally be segregated from vehicular traffic, in the interests of road safety, as accidents involving horses can be very serious. In addition, surfacing materials suitable for horses tend to be different from those provided for other road users. Where there is a requirement to provide facilities for horse riders, these shall be designed appropriately and agreed with the Council.

5.17.2 Where an equestrian route crosses a road, consideration should be given to the provision of a controlled equestrian crossing. In such a case, any layout should be in accordance with **Traffic Advisory Leaflet 3/03**, published by DfT, and also **DMRB TA 57 Roadside Features**.

5.17.3 There is no standard specification for surfaces used by horses and any design will depend on the number of horses likely to use a route and whether it will be shared with other users, such as pedestrians or cyclists. However, useful guidance can be found in the following documents:-

- **A Guide to the Surfacing of Bridleways and Horse Tracks** – available from the British Horse Society
- **Traffic Advisory Leaflet 3/03 Equestrian Crossings** (DfT)
- **Equestrian Access Factsheets** – available from Paths for All (www.pathsforall.org.uk)

Public Transport / Còmhdhail Phoblach

5.18 Public Transport Facilities / Goireasan Còmhdhail Phoblaich

5.18.1 *Introduction*

5.18.1.1 The Council considers improved public transport provision to be one of the key objectives in its transport strategy as good levels of public transport can both help ensure access for non-motorists and assist in reducing private vehicular trips.

5.18.1.2 In terms of public transport provision, it is essential that developers discuss this matter with the Council as early as possible, especially the Council's Public Transport Unit. Discussions may also need to be held with relevant bus operators to agree routes and levels of services. It should not be assumed that provision of suitable infrastructure will in itself ensure operation of a bus route, as commercial and wider network operational factors will influence operator decisions.

5.18.1.3 In planning new developments, the need to provide or enhance local bus services will have a significant impact on road layout design. In order to be as attractive as possible, bus routes must be reasonably fast and direct, connecting the centres of the residential, business and shopping areas that they serve. Public transport requirements will affect the design of a development in terms of road types, layouts, widths and pedestrian access requirements and should be provided in accordance with the guidance in **Inclusive Mobility** and **Disability Discrimination Act - Good Practice Guide for Roads**.

5.18.1.4 For new developments, especially large ones and those which will generate significant numbers of trips, there may be a requirement to provide new services or enhance existing ones. Developers need to acknowledge they are likely to be required to provide financial contributions towards public transport services and associated facilities, such as real time information or bus priority measures. In phased developments, public transport provision will be required from an early phase in order to enable a pattern of use to become established and to reduce car dependence.

5.18.1.5 Larger developments may increase the stress on the existing road network with congestion levels and journey times likely to increase. In these cases, a contribution towards off-site bus priority measures will be expected.

5.18.2 *Bus Routes*

5.18.2.1 Potential bus routes must be discussed with the Council at an early stage and early input from likely bus operators is also desirable. Bus routes should generally be direct and provide easy access for public transport vehicles.

5.18.2.2 Generally, bus services will be based on Main Distributor/Regional Route and Local Distributor/Sub-regional Route Roads if standard size vehicles are used. In some instances, a

demand responsive service will be more appropriate and this arrangement is actively encouraged where relevant within The Highland Council area and where the provision of community transport schemes is becoming a more common alternative to timetabled bus services.

5.18.2.3 Small public transport vehicles may be considered, to allow enhanced penetration into development sites but the feasibility of this will depend on wider operational requirements in the surrounding area. Where culs-de-sac are proposed, particularly within residential areas, suitable access and turning arrangements for Dial-a-Ride and Dial-a-Bus type vehicles, ie mini and midi buses for use by persons with reduced mobility shall be provided.

Design Requirements

Ideally bus provision or penetration for a development should be such that no dwelling or workplace is more than a 400-metre walk from the nearest bus stop. For other types of development, such as sheltered/retirement homes, schools, healthcare facilities and shops, bus stops should be located as close as possible to the front door of the facility.

Any roundabouts or turning circles likely to be used by buses must be of sufficient size to accommodate the vehicles, without the need to over-run footways.

5.18.2.4 The size of the expected catchment area will also affect bus route requirements and any need for financial contributions to enhance services and to help mitigate the impact of the development.

5.18.2.5 *Residential developments* – as part of the “400 metre” rule, the scheme layout should consider bus stop locations and how people can walk to and from them as directly as possible. This will influence the layout design. For many new housing schemes, especially those within rural areas, there is likely to be a demand for school buses and provision for these should also be considered. This should be agreed with the Council during the planning stage.

5.18.2.6 *Commercial developments* – shops will generate demand for travel by public transport, but the extent of demand will relate to the scale of development. For large schemes, such as retail parks or where a large food outlet is incorporated, public transport travel can be very significant. Where possible, bus services should be able to enter sites, especially larger ones, and facilities should be included that maximise the attractiveness of public transport. This will include taxis and community transport vehicles.

5.18.2.7 *Business and industrial developments* – individual employment or industrial premises are unlikely to warrant provision of their own public transport service, unless of a large scale. However, business parks or industrial estates will generate public transport demand, which should be addressed in a Travel Plan, and the appropriate level of public transport provision should be discussed with the Council. This could include modification of routes and services and/or involvement in some form of demand responsive provision.

5.18.2.8 *Recreation/leisure developments* – facilities such as sports centres and cinemas will generate public transport demand, especially by those persons without access to a car, such as children,

who are often dependent on public transport. Consideration should be given, therefore, as to what associated public transport facilities are appropriate.

Design Requirements

A development likely to generate significant levels of public transport use is to have a layout that ensures the main entrance is close to bus stops and that buses can access the stops by reasonably direct routes.

Conflict between pedestrians and car traffic should be avoided through appropriate design.

5.18.3 Road Widths for Bus Routes

5.18.3.1 Those roads that are or may be used as bus routes shall be suitable in width, alignment and construction, to accommodate public transport vehicles. Corner radii should take account of the fact that buses have a large swept turning circle in the order of 20-25 metres diameter, depending on length of vehicle.

Design Requirements

The minimum carriageway width for operation of buses in new developments shall be 6.0 metres. This should be increased to 7.3 metres, in discussion with the Council, where buses, travelling in opposite directions, are likely to pass each other on a regular basis.

5.18.4 Bus Stops and Shelters

5.18.4.1 For many developments it will be necessary for a developer to provide bus stop facilities, either new ones, upgraded existing ones or a combination of both, within a site and/or on surrounding roads. The actual requirements will be influenced by distance from existing stops, passenger demand, site layout and the road network. Bus stop layouts, including bus bays and boarders, together with turning arrangements should be provided, as appropriate, in agreement with the Council, especially its Public Transport Unit.

5.18.4.2 Appendix 7 sets out a Bus Stop Specification, which the developer will be required to comply with. In some instances, a bus bay may be appropriate whilst in others, a widened footway to provide a bus boarder might be more suitable and raised kerbs might also be required. Particularly busy bus stops may require widened footways. Nearby dropped kerbs should be provided to assist persons with mobility difficulties to cross the road and access the bus stops. A bus stop pole will be required, together with a plate showing the stop name and route numbers (the latter using replaceable tiles). Bus stop markings will also be required for most locations, including, in some cases, a Clearway marking in the carriageway channel and an associated time-plate, setting out times of restrictions for other vehicles.

5.18.4.3 A bus shelter will normally be required, in order to provide a more attractive waiting environment for passengers, sited so as not to interfere with visibility or footway widths. Bus shelters should include an information panel and provision of a real time information display may be required. All these facilities need to be provided, at the developer's expense, to a standard agreed with the

Council's Public Transport Unit. Where a bus stop is located on a public road or prospectively public road, its facilities will subsequently be maintained by the Council.

5.18.4.4 When determining bus stop locations, consideration should be given to the following:-

- Adequate unobstructed footway width
- Suitable space for a bus shelter
- On-street parking arrangements
- Close proximity to pedestrian crossings (and preferably on the exit side)
- Close proximity to the point where main pedestrian routes intersect the bus route
- Close proximity to local facilities e.g. shops, offices, pubs, residential areas

- Safety e.g. avoiding bends and crests in the road
- Visibility for road users (in both directions) when buses are stopped
- Potential impact on junction visibility splays
- Measures to ensure bus driver and intending passengers are clearly visible to each other
- Adequate frequency of stops along the route
- Location to minimise walking distance between linked interchange stops
- Close proximity to main junctions without affecting road safety or junction operation
- Close proximity to the heart of high density development
- Location to minimise likely objections from nearby residents

5.18.4.5 In addition, the designer should be aware that the need for a bus stop will have a direct influence on the design of a number of the above items (particularly the first six) within the overall layout design.

5.18.4.6 The location of a bus stop needs to be considered in relation to the pedestrian network, in order to minimise walking distances, as well as taking account of road crossing requirements and facilities. It is good practice to provide opposing bus stops near to each other, so that passengers can get on or off a bus in close proximity. However, they should not normally be directly opposite each other to avoid the risk of two buses stopping simultaneously and blocking the road. The spacing of bus stops will be influenced by density of development, but as a general guide, a spacing of some 250 metres is deemed appropriate in fully built-up areas. Rural areas are likely to have significantly greater spacings.

5.18.4.7 The siting of a bus stop can also raise environmental issues, particularly in relation to possible impacts on the occupiers of those premises that a bus stop will front. Where possible, a new bus stop should not be sited directly in front of a door or window, especially that of a residential dwelling. It is critical, therefore, that potential bus stop locations be designed into the overall development layout wherever possible and are agreed in advance with the Council prior to installation.

5.18.4.8 Designers should provide for current bus sizes and manoeuvrability. However, it is recognised that bus dimensions and manoeuvrability may change and, therefore, some extra space should be allowed for. This is particularly relevant where the bus stop is located within marked parking

or loading bays and a swept path analysis should be undertaken to ensure adequate space for a bus to manoeuvre has been provided.

Design Requirements

The bus stop stance length should be 15 metres in order to accommodate all bus types. At particularly busy bus stops, two stance lengths may be required.

5.18.4.9 Where an in-line bus stop already exists or is unavoidable, careful consideration will be required with regard to the provision of any raised kerb and footway, in the vicinity of the bus stop, to assist passengers boarding and alighting the bus. This is because raising a section of existing footway may impact on adjacent frontages, in terms of changing levels and possibly affecting surface water drainage.

5.18.5 Bus Boarders

5.18.5.1 Within areas restricted to speed limits of 30mph or less and where on-street parking or loading is permitted and space permits, bus stops should be built out from the front edge of the footway to allow buses to pull up parallel with the widened section of footway. The build-out, commonly called a bus boarder, should be sited so waiting passengers (and bus shelters):-

- do not obstruct passing pedestrian flows;
- bus passengers and bus drivers have an unobstructed view of one another;
- the bus can pull up parallel with the kerb in line; and
- can resume travel without requiring to wait for a gap in passing traffic.

A raised bus boarder should be provided with facilities as recommended in **Inclusive Mobility**. A bus boarder should not be provided on the outside of a bend where it could create a specific hazard to any vehicle that might accidentally leave the road and could hit the bus stop.

5.18.6 Bus Bays

5.18.6.1 Bus bays are introduced to maintain the free flow of traffic by eliminating standing vehicles on certain carriageways. In general, they are required on those roads where the speed limit is 40mph or higher. Standard bus bay layouts are shown in Figure 5.12.

5.18.6.2 The footway around any bus bay should be sufficiently wide to allow for the erection of a bus shelter. Unless the use is likely to be mainly used by alighting passengers, a bus shelter approved by the Council's Public Transport Unit should be provided.

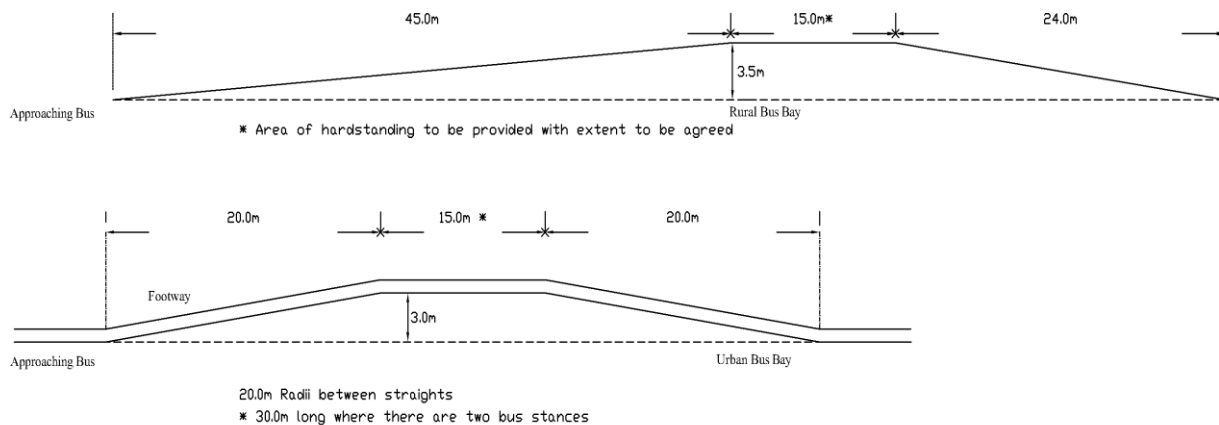

Figure 5.12 Standard Bus Bays – Rural and Urban

5.18.7 Lighting at Bus Stops

5.18.7.1 The provision of lighting at bus stops improves their environment and provides comfort to waiting passengers, in terms of personal safety. Lighting can be achieved by the provision of a street lighting column within the direct vicinity of a bus stop location. It is also possible to provide lighting as part of a bus stop pole but the appropriate type of lighting provision must be agreed with both the Council’s Public Transport Unit and Area Lighting Engineer. The lighting design should seek to ensure that the timetable notice can be read during the hours of darkness. Lighting may also be required within bus shelters, particularly at busy stops or at locations where there is less than a normal urban standard of street lighting.

5.18.8 Bus Turning Facilities

5.18.8.1 For a development requiring a public transport service, it is preferable that the road layout enables local bus services to divert easily through the development rather than needing to enter in, turn and then exit out of the site via the same access point. This can often be a significant influencing factor when a bus operator is considering whether to directly serve a development or not, or is calculating operation costs and any required subsidy.

5.18.8.2 It is likely that there will be instances where a turning facility or terminus is required. In residential developments, this should be located away from dwellings but for other developments should be sited as close as possible to the main building entrances. The design of the turning area or terminus, together with proposed construction materials, must be approved by the Council.

5.18.8.3 When a phased development is being constructed, it is important to provide suitable turning facilities, even if only on a temporary basis, for buses even though the bus route may only be

partially established. This will permit a bus service to be provided initially, which can then be extended as the development grows

5.18.9 **Bus Priority Measures**

5.18.9.1 Where potential conflict arises between the desire for bus routes to be reasonably fast and direct and the general objective of ensuring that residential and industrial roads are designed to encourage low vehicle speeds, some form of traffic management should be designed. This could be in the form of incorporating traffic calming measures that slow general traffic but not buses or by providing bus priority measures, such as bus-only links and bus gates. The provision of any such measure must be discussed and agreed with the Council.

5.18.10 **Real Time Information**

5.18.10.1 It is the Council's policy to install real time information (RTI) on the bus network. The requirements for the installation of associated display boards and infrastructure at bus stops should be discussed with the Council and is also likely to be required at significant travel-generating locations. This may include provision of RTI infrastructure within certain types of buildings. RTI equipment will have an impact on design layouts.

5.18.11 **Taxis**

Design Requirements

For new developments of over 2,000 m² gross floor area in size, taxi pick up and drop off bays are to be provided, with locations that provide easy access to the facilities.

In certain circumstances, the Council may request such facilities be provided for smaller developments, depending on their nature.

5.18.12 **Trains**

5.18.12.1 Where a large development is located close to a railway station, consideration as to how users of the development can be encouraged to access rail services is needed. This could involve improved access routes to the station and/or contributing to improvements at the station itself, eg, increased cycle parking facilities and/or car parking.

Servicing Arrangements / Ullachaidhean Seirbheis

5.19 Servicing Arrangements / Ullachaidhean Seirbheis

5.19.1 Introduction

5.19.1.1 Servicing of individual residential properties will generally be directly from the public road. For larger residential and small commercial developments, servicing will generally be undertaken via the private access serving the site; however, for major commercial and industrial developments, separate servicing access arrangements should be provided, in the interests of road safety.

5.19.1.2 If it is intended that any servicing shall be undertaken by parking vehicles on the public road this must be discussed with the Council, to agree suitable arrangements.

5.19.2 Commercial and Industrial Developments

5.19.2.1 The service areas in large commercial and industrial developments should be off-street and located to the rear or side of a building. The layout design should seek to provide servicing arrangements that are well segregated from pedestrian areas and the public road, in the interests of road safety.

5.19.2.2 Sufficient space shall be provided to accommodate the maximum number and size of vehicles likely to serve the development at any one time and to let them manoeuvre with ease and stand for loading and unloading without inconvenience to other site users. Service areas must be large enough and so arranged that all vehicles enter and leave the service area in forward direction, unless specifically agreed otherwise with the Council. Turning and reversing movements should be confined to areas off the public road and away from pedestrian activity. A swept path analysis should be undertaken to demonstrate manoeuvrability of the intended design vehicle within the road layout. Steps should also be taken to avoid the problems of indiscriminate car parking in servicing areas.

5.19.3 Loading Bays

5.19.3.1 Loads on platforms may overhang by 0.3 metres on each side and so, allowing for doors opening, the basic design module for loading bays is 3.3 metres wide. The length of loading bays is variable depending on the types of vehicle expected. Most vehicles do not have a greater overall height than 4.5 metres and, therefore, headroom of 5.3 metres is recommended in private areas and is necessary for adopted roads.

5.19.3.2 Where any loading/unloading activity is proposed to take place on a public road, there will be a requirement for a related Risk Assessment to be undertaken and submitted to the Council for prior approval, before such an activity would be deemed acceptable, as part of the design.

5.19.3.3 *Side loading bays* – Figure 5.13 shows a typical side loading bay arrangement.



Figure 5.13 Side loading bay

Design Requirements

Where vehicles are to be loaded or unloaded whilst parked parallel to the kerb of a service road, side loading bays 3.0 metres wide and at least 3 metres longer than the vehicles intended to use them, shall be provided.

The width of the service road shall be increased to allow a forklift to load or unload a vehicle, with a minimum width of 9.0 metres where the road has two-way flow, reducing to 6.5 metres if there is only one-way flow.

5.19.3.4 *End loading bays* - typical minimum dimensions for end-on loading bays, suitable for most service vehicles in the range up to 8 - 10 metres long are shown in Figure 5.14. These are based on the recommendations of the Freight Transport Association (FTA) and allow room to manoeuvre and shunt. The total depth required can be reduced where vehicles are parked at an angle with a saw-tooth loading deck but this arrangement is only usually appropriate when used with one-way circulatory service roads. The depth of the bays should be increased to accommodate articulated vehicles up to 15 metres long. Where bays are interrupted by columns supporting overhead structures, the spacing should be a multiple of the 3.3-metre module plus the thickness of the column.

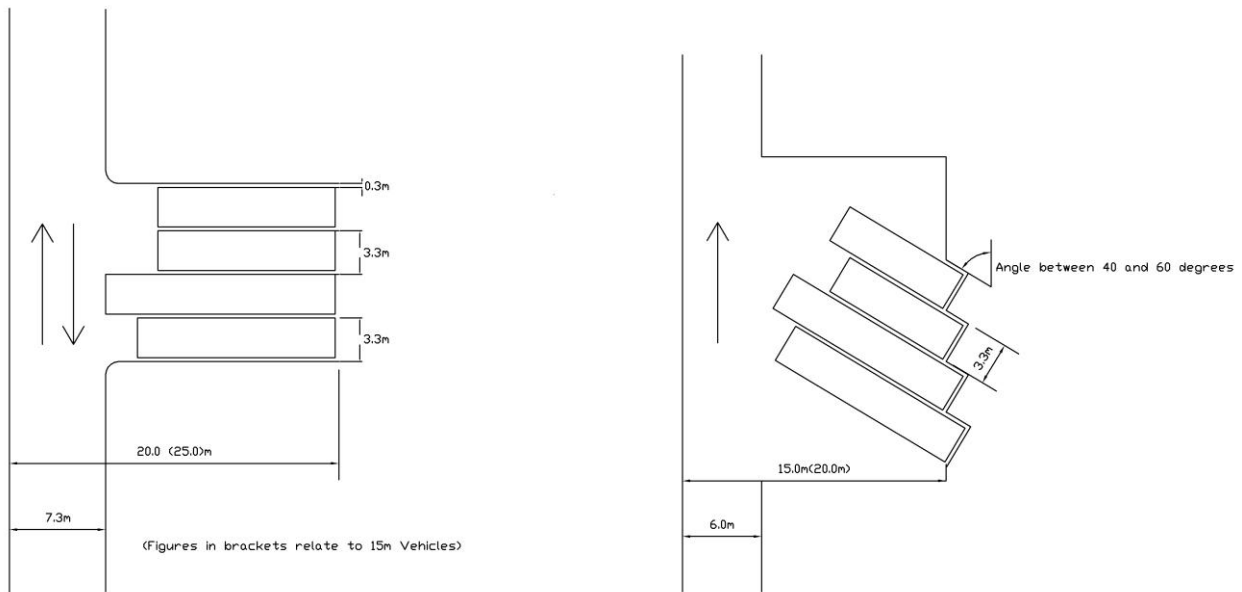

Figure 5.14 End loading bays

5.19.4 Service Roads and Ramps

5.19.4.1 Service roads shall be designed to at least Industrial Road Access standards, with particular emphasis given to widening of small radius bends and turning areas. Service roads may require a Road Construction Consent if they are to serve premises with more than one ownership and there is unrestricted access to the public. Figure 5.15 shows recommended curve widening for a service ramp.

Design Requirements

The gradient of straight ramps should not exceed 10% with a transitional grade of 5% at the break of slope.

Care should be taken with headroom, where ramps are involved, to allow for the bridging effect of long high vehicles. The height clearance at breaks of slopes may require to be considerably greater than the nominal 5.3 metres.

Curved service roads/ramps, particularly where two-way operation is involved, should be widened to allow for the swing of the inner rear wheel and the gradient of such ramps should be eased to 7% on the inner kerb line.

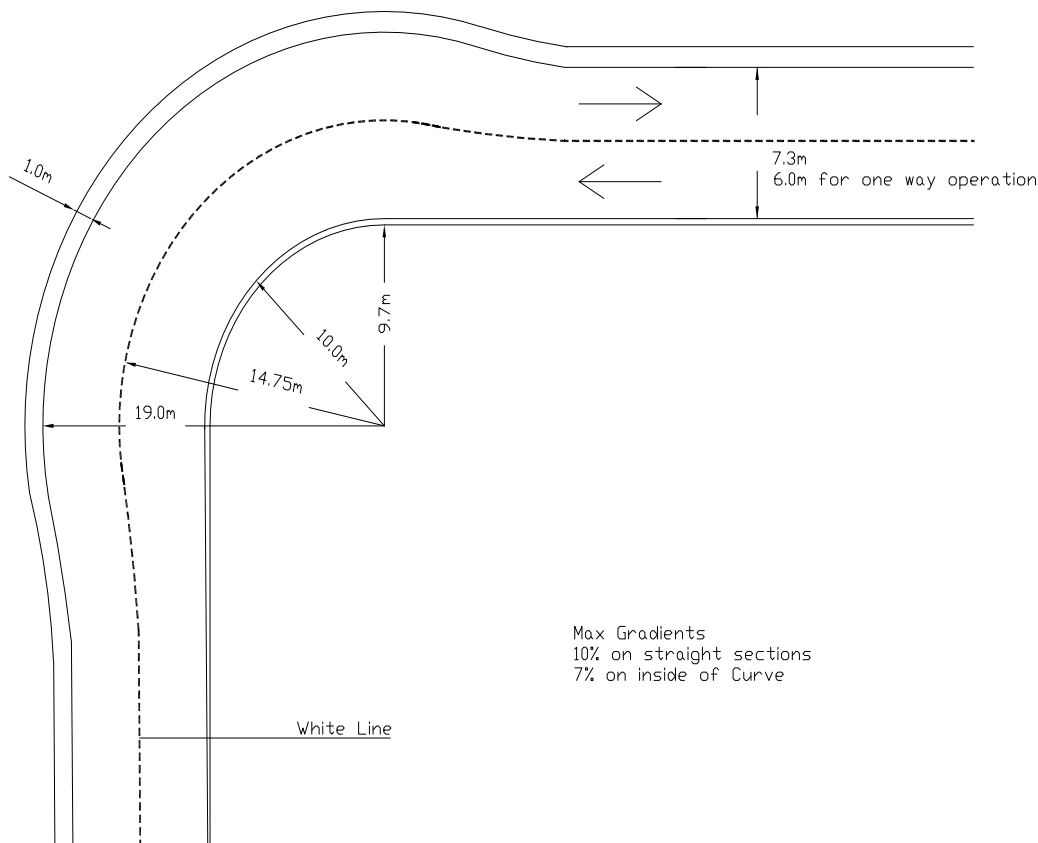

Figure 5.15 Curve Widening on Service Ramps

5.19.5 **Parking**

5.19.5.1 Provision must be made in commercial and industrial developments for the overnight parking of all associated vehicles off the public road. Where large numbers of servicing movements are anticipated, consideration should be given to the provision of parking bays for vehicles awaiting access to loading bays. Such parking bays should be located to ensure that vehicles using them do not interfere with the safe manoeuvring of any other vehicle. The dimensions of the parking bays should be similar to loading bays, but it is recommended that advice contained with the FTA **Designing for Deliveries** publication be considered.

5.19.6 **Fire Fighting Vehicles**

5.19.6.1 The width of roads and reinforced emergency vehicle paths and requirements for their proximity to buildings is detailed in Part E of the **Building (Scotland) Regulations**. The regulations specify a minimum clear width of 3.7 metres adjacent to low-rise dwellings, to facilitate the use of pumping appliances. The width of development roads, especially minor residential streets must be determined, taking account of these requirements, although it is assumed that emergency vehicles can use the full carriageway. Where buildings are 9 metres or more in height, the clearance width is to be increased to 4.5 metres, in order to allow the use of heavy rescue and fire fighting equipment. It should be noted that a 3.3 - 4.0-metre carriageway width may be appropriate for access but is not sufficient for the actual operation of a fire tender in this case.

5.19.7 **Refuse Collection Requirements**

5.19.7.1 The **Building (Scotland) Regulations** currently permit a maximum carry distance for individual dustbins of 46 metres. Where communal refuse storage accommodation is provided, the Regulations require that this be located no more than 15 metres from an access road suitable for use by refuse and recycling vehicles. Where such accommodation forms part of a chute system or is used for bulk refuse containers, the vehicular access should extend to the doors of the refuse accommodation area. However, **BS 5906 Waste Management in Buildings** suggests a maximum carry distance of 25 metres for individual waste containers, 10 metres for communal waste storage and direct access for bulk containers. It is recommended that these latter standards be adopted as far as possible.

5.19.7.2 Refuse vehicles currently used by Highland Council are 2.5 metres wide (excluding wing mirrors) and require a 22-metre diameter turning circle, as set out in Section 5.11.

5.19.7.3 Provision must be made for the standing of refuse bins off carriageways and footways where these are not collected from individual properties.

5.19.7.4 Developers are required to consult with the Council's Waste Management Services to discuss and agree requirements for refuse storage and collections. This can have a significant impact on the development layout and should, therefore, be undertaken early in the design process. Appendix 8 sets out the Council's current Refuse and Recycling Collection Requirements Policy.

5.19.7.5 For phased developments, there may be a requirement for temporary refuse collection measures to be implemented and these must be agreed with the Council. The developer should be aware that Council refuse vehicles will generally only travel on new development roads that have been adopted as public and for substantially complete un-adopted roads, interim measures must be agreed with the Council.

5.19.8 **Gully Emptying**

5.19.8.1 Road gullies need to be regularly cleaned and emptied. Occasionally, a gully may also require emergency attention, due to flooding or for some other maintenance reason. It is important, therefore, gullies are located in appropriate positions, as is reasonably practicable, so that gully emptying vehicles can stop without blocking the carriageway.

5.19.9 **Winter Maintenance**

5.19.9.1 The operation of winter maintenance vehicles needs to be considered in the planning and design of road and pedestrian networks, particularly in relation to gradients and turning requirements.

5.19.9.2 In addition, for some developments, depending on their size, layout and gradients, the Council may specify the provision of grit bins. Grit bins shall normally be sited on areas of hard standing located to the rear of the footway and be positioned so they are outwith any visibility splay.

5.19.9.3 For phased developments, there may be a requirement for temporary winter maintenance measures to be implemented and these must be agreed with the Council. Refer to Section 3.4.1.

Traffic Signs and Road Markings, Road Lighting, Traffic Signals and Statutory Undertakers / Soidhnichean Traftaig is Comharran Rathaid, Soillseachadh Rathaid, Teachdaireachdan Traftaig agus Gabhail Os Làimh Reachdail

5.20 Traffic Signs and Road Markings / Soidhnichean Traftaig is Comharran Rathaid

- 5.20.1 Only Scottish Ministers or the relevant Roads Authority may cause or permit traffic signs to be placed on or near any public road. Accordingly, proposals for the erection of any traffic sign or laying of any road marking must have prior approval from the Council, who may give advice as to type, colour and text height required.
- 5.20.2 **Designing Streets** encourages a relaxation in the provision of signage and road markings in certain circumstances. Whilst the Council acknowledges these aims and objectives, the developer must seek agreement with the Council with regard to what signs and markings are to be provided and where relaxations can be granted.
- 5.20.3 The developer shall be required to install, at his own expense, all necessary traffic signs and associated road markings, deemed necessary for the development. This could include alterations to existing signs and markings on the adjacent road network.

Design Requirements

Signs and markings need to be designed to comply with the current version of the **TSRGD**, the **TSM** and **BS EN12899-1:2007 – Fixed Vertical Road Traffic Signs** and also the relevant current parts of **BS 8442 – Road Traffic Signs and Internally Illuminated Bollards**.

Materials used for the manufacture of sign faces and associated poles must meet the relevant standards required by the Council.

Traffic sign poles, with their plates, need to be designed to withstand a wind pressure of 15 millibars, equating to 156kg/m².

Some poles may need to be protected by safety barriers and any such requirement must be agreed with Council. Alternatively, passive poles may be used.

- 5.20.4 When considering sign poles and columns, the provision of passive safety shall be the normal standard unless agreed otherwise with the Council. Guidance on passive safety can be obtained from **BS EN 12767 – Passive Safety of Support Structures for Road Equipment**.
- 5.20.5 *Road Markings* – junction markings should be provided at most junctions, unless agreed otherwise. Road marking materials shall comply with **BS EN 1436**.
- 5.20.6 *Street Nameplates* – in urban areas, particularly for residential developments, street nameplates should be provided as an integral part of the road network. Attention should be given to their location, so that whilst serving their purpose, they do not create a hazard, by obscuring visibility or creating a physical obstruction. In addition, future maintenance requirements need to be considered, such as landscaping that can, itself, obscure a street nameplate.

5.20.7 As per Section 3.3.7, the Council will provide advice, with regard to appropriate style, wording, lettering and the consultation/approval procedures, which comply with relevant Council policies. Some rural locations may require a street nameplate.

5.21 Road Lighting / Soillseachadh Rathaid

5.21.1 Introduction

5.21.1.1 Road lighting is an important aspect of the road design process. It is likely that the majority of the road lighting will be located on prospectively adoptable roads and the Council will adopt and maintain the road lighting. It is essential, therefore, that its design and materials used are acceptable. As a result, the developer should consult the Council, especially the Area Lighting Engineer (or his representative), to agree the lighting design, as early as possible. As mentioned in Section 3.3.6, it is recommended that the developer obtains a copy of the Council's Lighting Section document **The Specification for the Lighting of Roads in Housing and Developments**, as this gives relevant advice and guidance.

5.21.1.2 The Council will give advice on the type of lantern and lamp that may be appropriate for the development. The developer should remember the Road Construction Consent application needs to include drawings and detail that give information in relation to location and type of lighting columns; lanterns; feeder pillars; wall-mounted units, if proposed; paint colour and underground ducts, with their intended cabling material.

5.21.1.3 Provision and installation of prospectively adoptable road lighting shall comply with the current version of the **Specification for Highway Works**.

5.21.2 Design Requirements

5.21.2.1 Road, footpath and cycle track lighting shall be designed to comply with the requirements of **BS EN 13201** and **BS 5489**. The developer should seek advice from the Council with regard to the selection of lighting class to be applied to the design.

5.21.2.2 Where a cycle track provides shared facilities for pedestrians and cyclists, road lighting is to be provided that complies with **BS 5489**: Part 9, Section 3, Clause 14, with lighting levels as specified in its Table 6.

5.21.2.3 Where a developer proposes to use non-standard equipment, such as decorative or heritage columns and lanterns, this must be agreed with the Council. This is because decorative lighting equipment can have high future maintenance cost implications, so its use tends to be limited.

5.21.3 **Location of Equipment**

5.21.3.1 Whilst Road Construction Consent application drawings may indicate the proposed positions of all lighting equipment, there will be a requirement to determine the exact locations on site and agree them with the Council.

Design Requirements

Lighting columns shall be sited at the rear of a footway, unless agreed otherwise.

Where there is a 2.0-metre wide grass verge adjacent to a carriageway, the column should be sited at the rear of the verge, next to the footway edge. Where a wider verge is provided, the column should be sited 2.0 metres from the edge of carriageway.

If a lighting column requires to be sited more than 2.0 metres from the edge of carriageway, the appropriate column height and lamp wattage must be agreed with the Council.

If no footway is provided, the lighting column shall be positioned within the verge so that it has a minimum clearance of 1.0 metre from the edge of the carriageway.

Underground lighting cables should be run within 0.3 metres of the rear of the footway or verge.

If a surface lighting cable needs to be installed, its route must be agreed with the Council.

5.21.4 **Existing Services**

5.21.4.1 It will be the responsibility of the developer or his contractor to contact Statutory Undertakers for the purpose of establishing the position of any existing underground service.

5.21.4.2 The developer will need to obtain an electricity supply for the road lighting from an electricity supplier having cables in the area. The developer should be aware that he will be required to make arrangements with the relevant power supplier, with regard to paying for any electricity consumed by the road lighting installation prior to it being adopted by the Council. The developer will need to provide written confirmation of such an agreement.

5.21.5 **Defective Equipment Prior to Adoption**

5.21.5.1 In the event of the developer failing to provide operational road lighting installation adjacent to any occupied dwelling, prior to the lighting being adopted, then the developer will be served with a Notice instructing such provision to be made within 28 days. Failure to comply with such a Notice in the specified time period will result in the Council commencing procedures to call in the Road Bond to fund the completion of the road lighting installation.

5.21.5.2 In addition, if the developer or his contractor fails to rectify a fault in the road lighting, within a period of 5 days from the date of notification, the Council will arrange for a repair to be carried out, with all costs being subsequently invoiced to the developer.

5.22 Traffic Signals / Teachdaireachdan Traftaig

5.22.1 Introduction

5.22.1.1 There may be instances where vehicular access to a new development requires to be controlled by traffic signals. In such situations, the design of traffic signals and proposed equipment specifications that are associated with new development and which the Council will subsequently be requested to adopt must be submitted to the Council for verification and approval by the Council's Traffic Signal Engineer. For complex arrangements, submission should be during the Planning stage, so the Council can be satisfied that traffic flows can be accommodated on the road network. More basic layouts can be submitted as part of the Road Construction Consent application.

5.22.2 Design Requirements

5.22.2.1 **DMRB, Volume 6, Section 2, Part 3 TD50** covers the geometric design requirements for new signal controlled junctions and signal controlled roundabouts. Where possible, existing junctions being converted to signal control should also comply with these requirements.

5.22.2.2 **DMRB, Volume 8, Section 1, Part 1** covers the main elements of signal assessment, equipment and the principles of traffic signal design as listed in Table 5.13 below.

Table 5.13 Traffic Signal Design Reference Documents

| | |
|----------|---|
| SH 6/73 | Criteria for traffic light signals at junctions (Scotland) |
| TA 16/07 | General principles of control by traffic signals, as set out in TAL 1/06* |
| TA 82/99 | The installation of traffic signals and associated equipment, as set out in LTN 1/98* |
| TD 7/07 | Statutory approval of traffic control equipment |
| TA 15/07 | Pedestrian facilities at traffic signal installations, as set out in TAL 5/05* |
| TA 12/07 | Traffic signals on high speed roads, as set out in TAL 2/03* |

* - **DMRB** still refers to these documents within the new reference documents.

5.22.2.3 **Part 2** contains **TA84 Code of Practice for traffic control and information systems for all-purpose roads**. This CoP details best practice for signal controlled schemes, from inception to implementation of projects.

5.22.2.4 Details of signing and lining requirements at traffic signals are contained within the **Traffic Signs Manual Chapters 4 and 5**.

5.22.2.5 There are also a number of Traffic Advisory Leaflets that give guidance on aspects of traffic signal design and implementation. Some of these have been adopted into the DMRB, as noted above, but others remain as independent guidance documents. These include:-

| | |
|------------------|--|
| TAL 03/03 | Equestrian Crossings |
| TAL 01/02 | The Installation of Puffin Pedestrian Crossings |
| TAL 06/01 | Bus Priority |

5.22.2.6 Two other documents should also be referred to as part of the design exercise, namely '**Guidance on the use of tactile paving**' and '**Cycling by Design**'.

5.22.2.7 Configuration of the signal controller involves the specification of a number of different elements.

At the simplest level these are:-

- Phases and stages
- Intergreens
- Green times
- Mode of control

5.22.2.8 Phases and stages are the basic elements of signal control. A Phase is defined as a number of green lamp signals on the same circuit and a Stage is a collection of Phases. At a simple 'T' junction there would be two Phases for the main road traffic, one for each direction, and a Phase for the side road. Since both main road phases appear together, they would be grouped into a single stage called Stage 1 and the side road phase placed in Stage 2. Phases are denoted by letters and stages by numbers.

5.22.2.9 The Intergreens are the safety times taken to move from green on one Phase to green on another conflicting Phase. The minimum intergreen between traffic phases is five seconds.

5.22.2.10 Green times are the duration of green on a Phase. The minimum traffic green is generally seven seconds but can be lower in certain circumstances. Timings are usually obtained from a related traffic modelling exercise with the exception of pedestrian timings which are calculated according to the method given in **TAL 5/05 Pedestrian Facilities at Signal-Controlled Junctions** or the **TAL 01/02 - The Installation of Puffin Pedestrian Crossings**.

5.22.2.11 The mode of control is generally either Fixed Time (FT), Vehicle Actuation (VA) or Urban Traffic Management Control (UTMC) but the actual mode to be used for a new set of signals must be agreed with the Council, together with proposed time periods and phase timings. However, all new signalised equipment will normally need to be UTMC compliant and also include Remote Monitoring Facilities (RMF) complying with the Council's required specification.

5.22.2.12 The particulars of the controller operation are detailed in the **TR 2500 Specification**. This involves the completion of some 10 to 20 standard forms covering all aspects of the controller's operation. The designer is required to fill in the forms setting out the basic method of operation such as defining the Phases, Stages and intergreens. It is then possible to specify additional facilities, such as UTC control and bus priority, and their operation with a selection of optional forms.

5.22.3 **Installation – General Requirements**

5.22.3.1 In terms of the installation of traffic signals, the Council will normally expect the following to be provided, unless agreed otherwise:-

- Proposed traffic signal equipment suppliers must be approved by the Council;
- Each approach to have a minimum of two signal heads, a Primary located on the left at the Stop line and a Secondary usually located on the far side of the junction;
- Stop lines to be set a minimum of 2.5 metres from the Primary signal head;
- Pedestrian crossings to be indicated by two lines of aluminium road studs, usually set 3 metres apart;
- Tactile paving and dropped kerbs to be provided at either end of the crossing area;
- The tactile paving to be 'L' shaped with the corner of the 'L' next to the pedestrian push button;
- The pole carrying the pedestrian push button should be on the right of the crossing and set a minimum of 750mm back from the kerb face and no more than 450mm from the edge of the tactile paving along the kerb line;
- Erection of poles must comply with the standard construction technique as specified by the Council for all such installations;
- To assist the visually impaired identify the start of the crossing period the appearance of the green man should be accompanied by a rotating tactile cone underneath the pedestrian demand unit and/or an audible tone; and
- Vehicle detection shall be by a combination of inductive loops buried in the carriageway surface or Microwave Vehicle Detectors (MVDs) and/or Passive Infrared Detectors (PIDs) on the pole tops.

5.22.3.2 Figure 5.16 shows a typical layout of a signal controlled priority junction and illustrates the above installation requirements.

5.22.3.3 Any additional costs associated with the integration of new traffic signals equipment with the Council's current management and control systems will be payable by the developer.

5.22.4 **Maintenance Costs**

5.22.4.1 Where a new development involves prospectively adoptable traffic signals, the developer should be aware that the Council will normally require the developer to pay for any adjustments to the signals, including timing alterations, during the 12-month maintenance period. In addition, the Council will usually require the developer to provide a commuted payment to finance maintenance of the signals for a period of up to 15 years, commencing from the date of adoption of the signals (being currently some £500 per year and £7,500 in total).

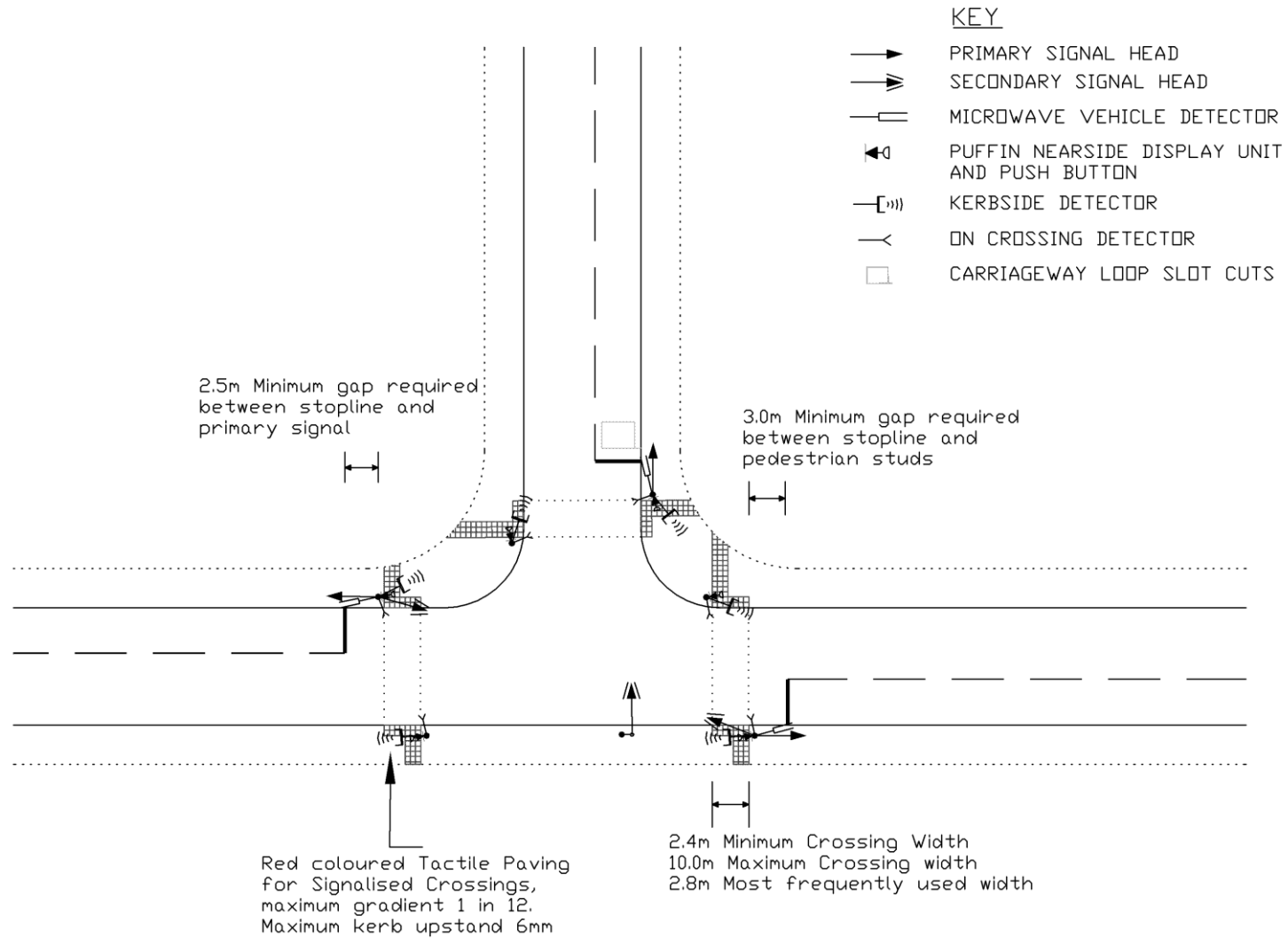

Figure 5.16 Typical Layout of a Signal Controlled Priority Junction

5.23 Statutory Undertakers / **Gabhail Os Làimh Reachdail**

5.23.1 **Introduction**

5.23.1.1 The provision of statutory or other services laid underground is a basic element of development design. The Statutory Undertakers, who provide such services, must, therefore, be consulted during the preparation of design briefs, so that their requirements can be co-ordinated into the design and agreement reached between their needs and other development objectives.

5.23.1.2 The Statutory Undertakers will wish to deal with one road manager, so that they are assured of protection, in terms of the **New Roads and Street Works Act 1991**. For new developments, the Council will only become the road manager once a relevant section of road has been added to the List of Public Roads. Until that time, the developer or his representative must act as road manager.

5.23.2 **Locations**

5.23.2.1 In the interests of both the Statutory Undertakers and their customers, all main supplies and services serving more than one proprietor should be located in land that is both publicly maintained and easily accessible. It is generally accepted, therefore, that these criteria are best met by public roads and, as well as making provision for all modes of transport, it is usually a function of most roads to provide routes for underground services.

5.23.2.2 Due to their size, sewers will normally be placed under the carriageway. Early consultation should be held with Scottish Water, with regard to its requirements, in accordance with the **Sewerage (Scotland) Act 1968**, for surface water sewers, the drainage of roofs and paved areas within the curtilage of premises and the foul water drainage system. For most systems, the developer will need to prepare a schedule of drainage so the system can ultimately be included in a **Section 7 Sewerage (Scotland) Act Agreement** between the Council and Scottish Water, to establish future maintenance obligations.

5.23.2.3 In addition, developers need to comply with SEPA's Best Management Practice, when designing surface water systems, in order to take account of its requirements for sustainable urban drainage systems (SUDS) to be provided.

5.23.3 **Service Strips**

5.23.3.1 All services, other than sewers and occasionally water mains, shall be grouped in "service strips" located within the limits of footways, verges, adoptable footpaths, with a minimum number of service connections running across the carriageway.

5.23.3.2 The width of a service strip will depend on the number and type of premises to be served. Normally, all domestic services (gas electricity, lighting, water and telephone) will be accommodated in a 2-metre wide reservation and Figure 5.17 shows typical positions for each

service, which are generally accepted as standard. However, Figure 5.17 is only a guide and does not absolve the designer from having to negotiate with each Statutory Undertaker, in turn, at the earliest possible stage. This is because, for each development, the depth, clearance and relative position of each service will require to be decided by the relevant Statutory Undertaker, with the method of cable and pipe laying left to their discretion. The majority of services are normally located within footways and special arrangements will be required where a footway is less than 2 metres wide. In addition, local widening in excess of 2 metres may be necessary to accommodate access chambers or where roads have tight bends.

5.23.3.3 The layout of service strips should be designed to accommodate phased developments and service plots. Hence, advance ducts, with draw strings, should always be installed to avoid any future un-necessary need to dig up roads and footways in order to subsequently lay services or provide connections, where possible.

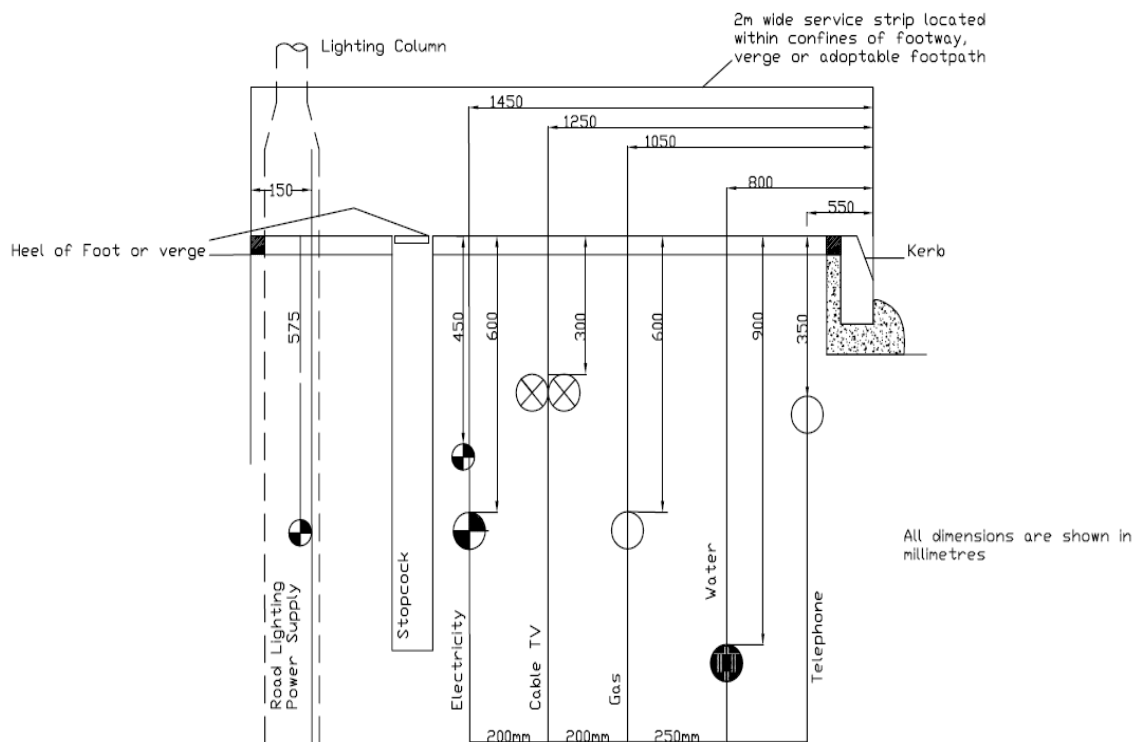

Figure 5.17 Recommended Statutory Utility Locations within the Service Strip

5.23.3.4 Where service strips are not located adjacent to carriageways, their width must allow for access by mechanical vehicles and/or plant for maintenance or repair purposes. In all cases, there must be a permanent and continuous demarcation of the boundary between the service strip and any adjacent private property. This can be achieved by methods such as a fence, wall or concrete edging.

5.23.4 **Design Requirements**

5.23.4.1 *Street Furniture and Road Lighting* - all street furniture, including road lighting columns, should normally be located at the rear of footways/footpaths or recessed behind them, with no item of street furniture or structure obstructing any road junction sight line, unless agreed otherwise with the Council. Conversely, no services, other than road lighting cables, should be located within 0.5 metres of the rear of the footway, in order to allow for lighting columns, joint pillars or other street furniture. Guidance regarding road lighting is contained within Section 5.21, with further advice available from the Council's Area Lighting Manager.

5.23.4.2 *Maintenance Access* – ready access must always be available to all parts of service routes, for both routine and emergency maintenance. Lorry access will be needed to some locations, such as manholes, electricity sub-stations, telecommunication junction boxes and gas governor house installations, with Statutory Undertakers' requirements for such facilities being ascertained at an early stage. Facilities should be positioned so as to minimise disruptions to vehicle and pedestrian access when service maintenance is being carried out, whilst seeking to ensure that necessary access to the facilities will not itself be obstructed by parked vehicles. Special consideration will be needed, in this respect, where services run underneath or adjacent to single lane carriageways and parking bays.

5.23.4.3 *Fire Hydrants* – the position of all fire hydrants should be agreed with the Fire Master and Scottish Water and be positioned so that vehicles are unlikely to park on top of them.

5.23.4.4 *Carriageway Crossings* – where service strips or branch corridors cross a carriageway, cabled services shall be individually ducted at increased depths, in accordance with the requirements of the Statutory Undertakers or as directed by the Council.

5.23.4.5 *Shared Surfaces* – in shared surface layouts, all services shall continue to be located within land eligible for adoption by the Council. In certain cases, this may require a service strip to be located underneath a shared surface, but in no circumstances will this be permitted at the entrance into a shared surface that has a narrow width, unless an alternative emergency access route can be provided. Where courtyards have informal turning head shapes, a service strip shall still be provided.

5.23.4.6 For shared surfaces, especially Home Zones, service strip requirements will form an integral part of the design process. Early consultation with all Statutory Undertakers will be essential, in terms of delivering successful shared surface developments.

5.23.4.7 *Special Surfaces* – where a road has special engineering properties, such as porous surfacing, there may be a need to provide dedicated crossing areas for services. Early consultation with the Council and Statutory Undertakers will be required, to agree locations and specifications.

5.23.4.8 *Manholes* – where manholes are located within the carriageway, careful consideration should be given to their positioning, to ensure that the carriageway is not closed when maintenance work is

being carried out, especially for culs-de-sac. For a two lane road, manholes should be located at the quarter point of the road, rather than on the centre line, but always with the general objective of avoiding the vehicle wheel tracks. In addition, manhole positions should seek to avoid awkward locations, such as at junctions, dropped crossings, stopping areas or tight bends, as well as avoiding likely wheel paths of cyclists and motorcyclists.

5.23.4.9 *Surface Finish* – the surface finish of all service strips must form an integral part of its surrounding environment and be acceptable for general maintenance requirements by the Council and, in some cases, the adjacent frontager. Service strips should be appropriately protected when there are risks of damage from occasional overriding by vehicles.

5.23.4.10 *Landscape Planting* – it is essential any adjacent landscape planting, especially trees, are clear of visibility splays and are located so their roots do not damage underground services or are themselves damaged as a result of maintenance of the services.

5.23.4.11 *Location Plans* – the proposed locations of all services within road boundaries are to be indicated on the plans submitted with the Road Construction Consent application.

5.23.5 ***Council and Statutory Undertakers' Access Rights***

5.23.5.1 Where verges, visibility splays and service strips are contiguous with private gardens, special attention will be required to ensure that the access rights of the Council and Statutory Undertakers are clearly understood by householders and tenants. At the same time, the developer must remember that one of the objectives of having some quiet streets, such as Minor Residential Streets, Cul-de-sac and Home Zones, is the closer integration of public and private landscaped areas, by encouraging householders and tenants to maintain verges right up to the edge of paved areas.

5.23.5.2 Boundaries between public road verge/service strip areas and private gardens must be indicated. This can be achieved by the careful attention to landscaping details, such as using setted or cobbled areas to highlight the locations of stop cocks, hydrants, manhole covers, etc. In addition, householders and tenants must be made fully aware that the building of walls and fences or the planting of deep rooted trees, shrubs and hedges within the delineated service area within a verge is prohibited and Statutory Undertakers have the legal right to excavate these underground services at any time. These requirements can be achieved by means of a condition being included in the missives of the affected property. In addition, Statutory Undertakers may wish to attach warning notices to meter boards at such properties.

5.23.5.3 Conversely, adjoining property owners should be given assurances that Statutory Undertakers are legally obliged to reinstate service strips to a required standard, following any maintenance works.

5.23.6 **General Construction Requirements**

5.23.6.1 Any person wishing to install services or apparatus in a public road must apply to the Council for a Road Opening Permit, in terms of the **Roads (Scotland) Act 1984** or obtain permission in writing, in terms of the **New Roads and Street Works Act**, before any excavation is undertaken within the public road.

5.23.6.2 The developer or his agent is responsible for contacting the relevant Statutory Undertakers regarding the position of any existing underground plant and seeking permission to connect to such plant.

5.23.6.3 Under the terms of the **New Roads and Street Works Act**, it is the duty of a developer to inform the Council of any unidentified apparatus that is found.

Road Structures / Structaran Rathaid

5.24 Road Structures / Structaran Rathaid

- 5.24.1 Given the likely complexity of any structure, this Section of the document does not provide any design standards or recommendations. If a new development does require a road structure, then the procedures, as set out in Section 3.1.7, shall be followed by the developer and his Designer.
- 5.24.2 Where a structure is proposed, then it is re-iterated that the applicant or his engineer/Designer should **make very early contact** with the Technical Approval Authority (TAA), to discuss and agree type, design, materials, construction and future maintenance requirements.

Road Drainage / Drèanadh Rathaid

5.25 Road Drainage / Drèanadh Rathaid

5.25.1 *Introduction*

5.25.1.1 All developments require to be drained, in order to remove excess surface water, and providing adequate drainage is another basic element of the development design. In general, a road surface water drainage system shall not accept roof water and surface water drainage from adjacent properties, which shall be treated separately, preferably on site. If a combined surface water system is proposed, this must be discussed beforehand with the Council and Scottish Water, who will normally require the developer to prepare a schedule of drainage so that the system can ultimately be included in a **Section 7 Sewerage (Scotland) Act Agreement** between the Council and Scottish Water, to establish future maintenance obligations.

5.25.1.2 The Highland Council will adopt drainage systems that exclusively contain road surface water from adopted roads but will only adopt drainage systems containing curtilage water under a Section 7 Agreement between Scottish Water and the Council.

5.25.1.3 Road drainage has traditionally involved the provision of underground pipe systems that are designed to accommodate the envisaged quantity of runoff water, in order to prevent local flooding. However, as these piped systems remove the runoff more quickly than if it were left to flow naturally, they have the potential to cause problems in other areas.

5.25.1.4 In recent years, water quality has become a more important issue, as a result of the problems associated with pollutants from developments and roads being carried into watercourses and groundwater. The traditional piped systems tend not to be able to address this problem and may, in fact, contribute to it.

5.25.1.5 Dealing with surface water drainage from new developments in an effective manner that results in no flooding or pollution, whilst also enhancing the local environment, requires schemes to be designed in a manner that goes beyond the conventional approach to drainage. Road drainage schemes are now usually required to employ sustainable urban drainage systems, commonly referred to as SUDS. Where a drainage system discharges into an existing watercourse or public sewer, the system will also need to meet additional requirements, as deemed necessary by the following bodies:-

- Foul or Surface Water Sewers – Scottish Water
- Water Quality and Quantity – SEPA
- Flood Prevention – The Highland Council

5.25.2 **Sustainable Urban Drainage Systems**

5.25.2.1 Sustainable urban drainage systems (SUDS) seek to act like natural systems, in terms of treating polluted surface water, whilst also providing attenuation of the water, in order to reduce its detrimental impact on watercourses. In addition, well designed SUDS measures, such as ponds, which are not underground can provide a positive contribution to the amenity of a site, in terms of landscaping and wildlife.

5.25.2.2 SUDS comprise a number of features that manage surface water runoff and control pollution.

There are four general types of features:-

- Filter drains and permeable surfaces
- Filter strips and swales
- Infiltration devices
- Basins and ponds

5.25.2.3 The features are most effective, in terms of water attenuation, when they are placed as close as possible to where rainwater falls, so that the runoff can be captured early. The features can also provide treatment for carried pollution particles, within the surface water, using the natural processes of sedimentation, filtration, adsorption and biological degradation.

5.25.2.4 To aid drainage designers, reference should be made to **The SUDS Manual (C697)**, published by CIRIA and also the **SUDS for Roads** guidance manual produced by SCOTS. Further SUDS guidance and good practice advice can be obtained from SEPA (www.sepa.org.uk). Reference should also be made to **Sewers for Scotland 2**, published by Scottish Water (www.scottishwater.co.uk), as this sets out technical requirements, which must be met.

5.25.2.5 Each development will be considered on a site-by-site basis, in order to determine the most effective combination of SUDS features, together with the required level of treatment. The developer must allow sufficient landtake for these features, when designing the site layout, as some, such as basins and ponds, can require significant areas of land.

5.25.2.6 Where SUDS features are proposed, an agreement between the developer and Council and/or Scottish Water, in respect of future maintenance requirements and responsibilities will be required. The developer should discuss the limits of maintenance with the Council as early as possible.

5.25.2.7 The developer should be aware that maintenance of new watercourses, basins and cut-off drains will rest with the respective owner, unless agreed otherwise with the Council and/or Scottish Water. The developer must make prospective owners aware of their future potential maintenance responsibilities. It will be important that on-going maintenance of such drainage features is carried out. To aid this, open space adjacent to the features needs to be provided and reserved in order to ensure access. For example, it is recommended that a 3-6 metre wide access strip be provided adjacent to any watercourse, extending to a nearby public road and

reserved for access. Such spaces should exclude private garden areas and there will need to be agreement on extent, ownership and maintenance of these associated open areas.

5.25.3 Design Requirements

5.25.3.1 Where the drainage design is undertaken by the developer, it must comply, in all respects, with the requirements of Scottish Water and SEPA, and be approved by the Council and is likely to require SUDS features. Foul drainage shall be designed to the standards required by Scottish Water. Drainage design should be considered as early as possible and discussed with relevant bodies during the pre-application and outline planning stages.

5.25.3.2 Where a piped road drainage system is permitted, it shall be designed in accordance with the current editions of the **DMRB** and **SUDS for Roads**, subject to the qualification that the minimum permitted pipe diameter shall be 150mm. Unless agreed otherwise with the Council, measures must be incorporated to prevent surface water flowing on to a public road from adjacent private properties.

5.25.3.3 The spacing of road gullies shall be designed in accordance with Transport Research Laboratory **LR277 “The Hydraulic Efficiency and Spacing of BS Road Gullies”**. Standard road layout gully spacings, derived from LR277, are shown in Table 5.14. The spacing may require to be adjusted, according to the road layout, eg, at junctions, sags, crests, etc and advice should be obtained from the Council.

Table 5.14 Gully Spacings for Carriageways

| Cross Section | C/way width | Gradient | | | | | | | |
|-----------------------------|-------------|-----------------------------|----------------|----------------|---------------|---------------|---------------|---------------|---------------|
| | | Flatter than 1/150 0.66% | 1/150 0.66% | 1/100 1.00% | 1/80 1.25% | 1/60 1.66% | 1/40 2.50% | 1/30 3.33% | 1/20 5.00% |
| | | Gully Spacing (metres) | | | | | | | |
| 1 in 40 (2.5%) Camber | 5.5 m | 20 | 30 | 35 | 40 | 45 | 55 | 60 | 75 |
| | 6.0m | 20 | 25 | 30 | 35 | 40 | 50 | 60 | 70 |
| | 7.3m | 15 | 20 | 25 | 30 | 35 | 40 | 45 | 55 |
| 1 in 40 (2.5%) | 5.5m | 10 | 15 | 17 | 20 | 22 | 27 | 30 | 37 |
| | 6.0m | 10 | 12 | 15 | 17 | 20 | 25 | 30 | 35 |
| Crossfall | 7.3m | 7 | 10 | 12 | 15 | 17 | 20 | 22 | 27 |

Notes:- 1. The desirable minimum permitted channel gradient is 1/125 (0.8%) but with an absolute minimum of 1/200 (0.5%) considered in exceptional circumstances.

2. Spacings are based on assumption of 2.0-metre wide footways on both sides of carriageway. There may be a need to amend spacings where wider footways are provided.

Design Requirements

Irrespective of design spacings, a gully shall be positioned as follows:-

- just upstream of the tangent point at road junctions;
- short of the point where adverse camber is removed when applying super-elevation;
- at any localised low point, where two gullies shall be installed;
- just up-stream of traffic calming features, where necessary; and
- to avoid pedestrian crossing points or driveways, but located just upstream of them, where possible

5.25.3.4 For irregularly shaped areas, the empirically-derived formula of one gully for each 200m² of catchment area may be used. Additional gullies will be required where gradients are steeper than 1/20 (5%), flatter than 1/150 (0.66%) or where surface water draining from adjacent areas may be anticipated.

5.25.3.5 Generally, channel gradients shall not be flatter than 1/125 (0.8%). Where this is not possible, special drainage measures may be necessary and agreement should be sought from the Council.

5.25.3.6 Remote footpaths/cycle tracks shall be constructed with flush edging and adjacent land drainage, so that surface water can drain naturally. Only in exceptional circumstances should direct drainage into gullies be considered, with approval required from the Council. If such footpaths are prospectively adoptable, the adjacent drainage system will also be adopted, if constructed to appropriate standards.

5.25.3.7 Lay-bys shall be drained by means of either having road gullies located in the rear of the lay-by, thereby seeking to avoid wheel tracking wherever possible, or by use of a filter drain where there is a verge but no kerb. Where the lay-by crossfall is towards the main carriageway, drainage requirements must be agreed with the Council.

5.25.3.8 Where soakaways are incorporated into a drainage system, they shall be designed in accordance with the requirements and recommendations of **BRE Digest 365 Soakaways** and **CIRIA R156 "Infiltration drainage – manual of good practice"**, to suit the drainage characteristics of surrounding ground material. Soakaways should be sited so that the integrity of nearby structures and roads are not impaired by a potential change in water table levels. Adequate vehicular access is to be provided to allow for occasional maintenance. Where privately owned soakaways are to be used, being either existing or new facilities, approval of their use and future maintenance regime must be agreed between the developer, Scottish Water and the Council.

5.25.3.9 The drainage design must consider the whole of the site. Whilst drainage of the road network and building roofs are likely to be the main sources, runoff from open spaces and any other drainage must also be taken into account. As a result, detailed proposals for dealing with runoff from the whole site must be submitted for approval.

5.25.3.10 In addition, existing land drainage may be present on a site and is likely to be affected by the development proposals, probably having an impact on drainage requirements. The drainage design needs to take account of such land drainage and proposed measures for accommodating it must be submitted for approval. Proposed measures can include cut off drains, constructed above and below a development, if appropriate.

5.25.3.11 The drainage designer should be aware that land drainage or other appropriate measures must be taken to prevent water flowing onto a public road from adjacent properties. Conversely, the layout of a development, in terms of gradients and routes, needs to be checked to prevent excess road surface water or any overflowing watercourse that comes onto a road being directed towards properties, thereby exposing them to the risk of flooding. Such a check should include an assessment of low points, in terms of the risk of overflow due to gully blockages and extreme events and any likely impact on nearby buildings. The check must consider flood routes and potential depths.

5.25.4 **Drainage Connection**

5.25.4.1 Connection of a road drainage system to an existing sewer can only be undertaken with the authority of Scottish Water, whilst discharge into a watercourse needs the approval of SEPA and also the Council, as the local Flood Prevention Authority.

5.25.4.2 Use of an existing sewer could significantly affect its capacity and have a detrimental effect on combined sewer overflows, such that changes to the foul sewer network may be necessary. The developer must consider this aspect and submit proposals for alterations, with capacity calculations, for approval by both the Council and Scottish Water.

5.25.5 **Sub-grade Drainage**

5.25.5.1 As well as providing a surface water drainage system, it is also important that effective drainage of the sub-grade is provided, together with drainage of any other permeable layers of a road.

5.25.5.2 Where a road has no direct frontage development, the sub-grade drainage is likely to require the following features:-

- Filter drains should be installed at the foot of cuttings and slopes, where it is deemed necessary to prevent the flow of water across footways and also to protect carriageway foundations and earthworks slopes. Drainage should be positioned deep enough to ensure that the water table does not rise to within 0.6 metres of the formation level.
- Where an embankment is formed, the capping layer and/or sub-base layer shall be extended to the face of the embankment slope to aid drainage of these layers.

5.25.5.3 The surface of any filter drain should have a dished concave shape to help catch water. In addition, a catch pit could sometimes be provided with a grating cover rather than a manhole cover, especially within rural areas.

5.25.5.4 In rural locations, it will usually be acceptable for a ditch to be provided instead of a filter drain.

5.25.5.5 Where a road does have direct frontage development and there are no adjacent slopes, then there is unlikely to be a need for any specific sub-grade drainage features, unless a ground investigation suggests the water table is within 0.6 metres of formation level or that material below formation level is significantly impermeable. In such cases, some form of positive sub-grade drainage should be installed.

5.25.5.6 *Permeable block paving* - in some locations, such as parking areas and courtyards, consideration should be given to installing permeable block paving, with an appropriate drainage system within the sub-base and/or sub-grade. Such block paving does require regular maintenance, in terms of inspection, cleaning and vacuum sweeping of the surface. The Council may adopt suitable areas of permeable block paving and this matter should be discussed at an early stage in the design process. There would be a need to check the sub-grade to ensure that it was suitable and can retain its strength when saturated, otherwise an impermeable membrane would be required. Guidance on permeable paving is set out in **SUDS for Roads**.

5.25.6 ***Drainage Impact Assessment***

5.25.6.1 The detailed drainage layout for a development will need to be submitted, as part of the Road Construction Consent application, together with design calculations. In addition, the developer should be aware that for many applications, a Drainage Impact Assessment must be provided, as part of the supporting information for a "Planning in Principle" application, with full drainage details and calculations provided as part of the detailed planning application.

5.25.6.2 The Drainage Impact Assessment is to be site-specific and highlight all drainage issues that relate to the site, together with impacts of the development. Information of proposed outfalls and/or connections, together with an indication of likely SUDS measures, should also be provided. In association with the Assessment, it is also important that a plan, showing existing and proposed ground level contours, including road, floor and garden levels, is provided by the developer, as development in a valley or depression is more likely to be prone to flooding.

5.26 **Flooding Issues**

5.26.1 Before considering the development of a site, commencing a layout design and assessing road and drainage requirements, a developer needs to be aware of any potential flooding issue that could affect the site and prevent its development. This includes the site being prone to existing flooding or the development creating or exacerbating flooding either on the site or for nearby locations. More detailed advice with regard to flooding is provided in Chapter 8.

Other Design Requirements / Riatanasan Dealbhaidh Eile

5.27 Other Design Requirements / Riatanasan Dealbhaidh Eile

The following items may be additional design requirements for certain developments that the developer should take into account.

5.27.1 *Access to Play Areas*

5.27.1.1 For those developments where a play area is required or provided, this should usually be within areas of open space but which are overlooked. The play area should be sited in appropriate locations so that most children can safely walk or cycle to and from them, without the need for adult escort.

5.27.2 *Traffic Noise*

5.27.2.1 The developer should be aware that the Council shall usually require new residential developments to be designed to take external noise into account, which will include noise generated by traffic. Hence, the designer should consider the following sources of traffic noise:-

- new roads, constructed as part of the development;
- existing roads, adjacent or near to the development;
- changes to the existing road network to accommodate the development;
- changes to the existing road network, as listed in the Council's Local Transport Strategy for implementation within five years, adjacent to or near the development.

5.27.3 *Safety Barriers and Fences*

5.27.3.1 A new road layout, provided as part of a proposed development, must be designed to promote road safety. There may be circumstances where vehicle restraint systems, usually in the form of safety barriers or fences, need to be provided, with their main objective being to prevent vehicles leaving the carriageway (and entering areas where they could create a hazard or increasing risk of serious injury to the vehicle occupants). There may also be situations where provision is required to prevent pedestrians or cyclists entering onto the carriageway or protect them from falls. For example, a culvert headwall with a drop exceeding 1.5 metres requires some form of pedestrian restraint, as a minimum.

5.27.3.2 In relation to the provision and design of safety barriers and fences, the developer shall take account of the requirements of **DMRB TD19 Requirements for Road Restraint Systems**, in terms of when barriers and fences are needed and their specification. There is also a requirement to comply with the associated **Road Restraint Risk Assessment Process (RRRAP)** that is used to assess if some form of barrier is required or not. Any requirement must be agreed with the Council.

5.27.4 **General Construction Traffic**

5.27.4.1 All developments will generate construction traffic to some extent. For large developments, the level of construction traffic may be significant and should, therefore, be considered as part of the general design process. Awkward sites, including small developments, may present access problems, requiring solutions to be agreed with the Council, such as the use of haul roads or Temporary TROs. Appropriate and careful design can help to minimise the impact of construction traffic and the developer should seek to mitigate any detrimental impact.

5.27.4.2 In some circumstances, the Council will require the developer to enter into a suitable legal agreement, usually in terms of either Section 56 or Section 96 of the **Roads (Scotland) Act 1984** to undertake any necessary improvements to the surrounding local road network, in order to accommodate construction traffic or to fund any remedial work to repair any damage caused by such traffic. Further information on this aspect is provided in Chapter 9, which also considers abnormal loads.

5.27.5 **Special Features**

5.27.5.1 In some exceptional cases, a new development will either incorporate or impact on special features not covered within this document. Examples might be:-

- a railway line or level crossing (where Network Rail would need to be consulted);
- need for a cattle grid; or
- a development near Inverness Airport and its flight path.

5.27.5.2 Where a special feature has implications on the design of a development or its access arrangements, the developer must discuss the matter with the Council.

CHAPTER 6 – PARKING / CAIBIDEAL 6 – PARCADH

6.1 Introduction / Ro-ràdh

- 6.1.1 Car parking is an important criterion in terms of influencing how people travel. As a result, the provision of parking standards for new developments is a valuable tool for helping to set and achieve the Council's transport strategy.
- 6.1.2 Car parking is an important aspect of a new development. However, it is equally important that a development also encourages travel by sustainable modes of travel, so the design and provision of facilities for pedestrians, cyclists and public transport must also be carefully considered.
- 6.1.3 Parking design issues and requirements are considered in Section 6.3, whilst Section 6.4 sets out the Council's current parking standards for development control. For all proposed developments, it is recommended that the developer discuss parking requirements with the Council as early as possible. For residential streets, additional guidance on parking layout is provided in **Designing Streets**. Useful parking guidance is also provided within "**Transport in the Urban Environment**", produced by and available from the Institution of Highways and Transportation.

6.2 Policy and Objectives

6.2.1 National Policy

- 6.2.1.1 Scottish Planning Policy (**SPP**) recommends that planning authorities should set their own maximum parking standards, in order to encourage modal shift away from the private car. **SPP** does set national maximum parking standards for specific types and scales of development. The parking standards within this document are based on these national maximum standards.
- 6.2.1.2 However, **SPP** does recognise that where an area is well served by sustainable modes of travel, reduced parking standards may be appropriate but that in rural areas, where public transport is scarce, less restrictive standards are acceptable.

6.2.2 Council Policy and Objectives

- 6.2.2.1 The Council's transportation policies are set out within its **Local Transport Strategy**. These policies aim to reduce car dependency by promoting walking, cycling and high quality public transport, together with reducing the need to travel where possible. However, it is recognised that for many people, particularly those living and working within rural areas, the car will remain a vital means of transport. A number of these transportation policies can be influenced by the amount of parking provided for new development. The Council's parking standards and how they are implemented for new development is considered to be consistent with **SPP**.

6.2.2.2 In terms of parking policy, the Council's key objective is:-

To contribute to achieving Local Transport Strategy objectives relating to Economy; Environment and Health; Integration and Road Traffic Reduction.

whilst detailed parking objectives are:-

- *to aid traffic management;*
- *to encourage and support business and shopping activities in all city, town and village areas;*
- *to be cost effective;*
- *to reduce demand for long term parking while increasing short term parking opportunities;*
- *to support alternative modes of transport and relieve congestion; and*
- *to direct the public's view and perception of parking charges such that they are not viewed as pernicious charges but as good traffic management.*

6.3 Parking Design

6.3.1 General

6.3.1.1 When car parking is provided as part of a development, it must be located appropriately, such that vehicles do not impede traffic flow or create a safety hazard. Off-street parking can be provided in the form of open surface car parks, in multi-storey units or within buildings. However, there may be circumstances where on-road parking is deemed acceptable, especially when provided in the form of lay-bys, particularly in terms of meeting the needs of people with disabilities or short-term visitor parking.

6.3.1.2 The locations of all car parking areas in a development should be considered at an early stage in the design process. There is also a requirement to agree which parking spaces are to be subsequently adopted by the Council.

6.3.1.3 Pedestrian access to premises should be arranged so that it is easier and more convenient to use the designated parking areas than to park casually on the road.

6.3.1.4 It is important that car parks are properly managed, especially large facilities, in order to provide and maintain a high standard of service and help discourage indiscriminate parking taking place elsewhere. Such management may include the introduction of a charging regime.

6.3.2 Residential Developments

6.3.2.1 The design of housing, new roads and parking spaces should always be undertaken at the same time, as the three requirements influence each other. It is likely that parking will be a mix of both on-street and off-street spaces, with the on-street spaces usually meeting the short-stay demand generated by visitors and loading/unloading needs whilst off-street spaces provide the long stay spaces for residents. There can also be a mix of allocated and communal spaces.

- 6.3.2.2 In residential developments, parking spaces reserved for the exclusive use of certain residents and/or their guests should be located within the curtilage of each property, wherever possible but this cannot easily be done with flats or terrace-type housing. Curtilage parking is most readily achieved by the provision of private driveways. The size of individual in curtilage parking spaces shall satisfy the requirements of Fig. 6.1 and Section 6.3.4, Parking Bay Design.
- 6.3.2.3 If curtilage parking is not provided, the location and surface treatment of off-road communal parking areas for residents should emphasise their private nature. In localities where there is a significant demand for public car parking, private spaces should be screened from public view and take access via a gateway or pend fitted with a lockable barrier. Alternatively, spaces should be individually controlled by means of lockable bollards.
- 6.3.2.4 Large parking areas tend not to be successful if remotely located from buildings, especially if vehicles can park on-street and be closer to the buildings than the car parks. In addition, expansive car park areas, with hard landscaping, may not be aesthetically pleasing. Accordingly, in low to medium rise development, small parking areas in close proximity to dwellings or buildings are advised and car parks should be located so that cars can be readily seen. Such off-street parking areas will not normally be taken onto the List of Public Roads but this should be discussed with the Council.
- 6.3.2.5 Parking areas provided for communal use by casual visitors should be located so as to be obvious to strangers coming into the development. It will often be appropriate for such public parking to be located in formal on-street lay-bys, since their presence can positively discourage indiscriminate kerbside parking elsewhere on the road. The maximum walk distance for visitors' spaces should normally be limited to 45 metres, especially for those persons with mobility difficulties.
- 6.3.2.6 Where communal parking areas for residents, such as lock-up garages, are provided at some distance from the dwellings they serve, some convenient temporary parking for residents' cars to allow occasional loading and unloading activities to be undertaken may be appropriate.
- 6.3.2.7 For those developments within city or town centres that seek to encourage a more sustainable environment, either being car-reduced or car-free, the maximum walking distance for residents shall be increased in order that cars are removed from the immediate area of such a development. The layout should discourage long-term parking near dwellings, by having communal parking located at the edges of the development, but still permitting vehicular access for short-term parking, such as loading or unloading and service/emergency vehicles. In such developments, it is critical that high quality pedestrian and cycle facilities are provided within the site, together with attractive access to nearby frequent public transport services.
- 6.3.2.8 As areas of parked vehicles can be visually intrusive, careful consideration needs to be given to their design. Choice of materials and the provision of landscaping can help soften the impact of rows of parking bays and should be incorporated into the design. If possible, such off-road

parking should be located so that the spaces are overlooked by adjacent premises, to improve their security.

6.3.2.9 Vehicular access from a public road to off-road parking areas will usually be taken via a dropped footway crossing. However, for large car parks, which are liable to generate significant flows of traffic, the access should be in the form of a road junction. In such cases, the car park access should be constructed to Main Residential Street standards, but a reduced carriageway width may be appropriate if one-way operation is provided.

6.3.2.10 Consideration should be given to widening driveways of houses in order to allow for visitor parking. Where garages or car ports are provided within the curtilage of a property, they shall have a minimum set-back of 6 metres, as shown in Figure 6.1. For driveways accessing onto busy or high speed roads, the driveway needs to have a turning area of sufficient size to allow vehicles to enter and exit in forward gear, for road safety. Individual driveways should join the main road or accesses at an angle of not less than 75° and no driveway should lie within 15m of a junction with other residential roads or 25m from a junction with a distributor road.

6.3.2.11 Where garages are provided within the curtilage of a property, a single car garage will not count towards the required parking provision; however, a double garage of minimum dimensions, 5.5 metres wide x 6metres long, will count as one parking space towards the required provision.

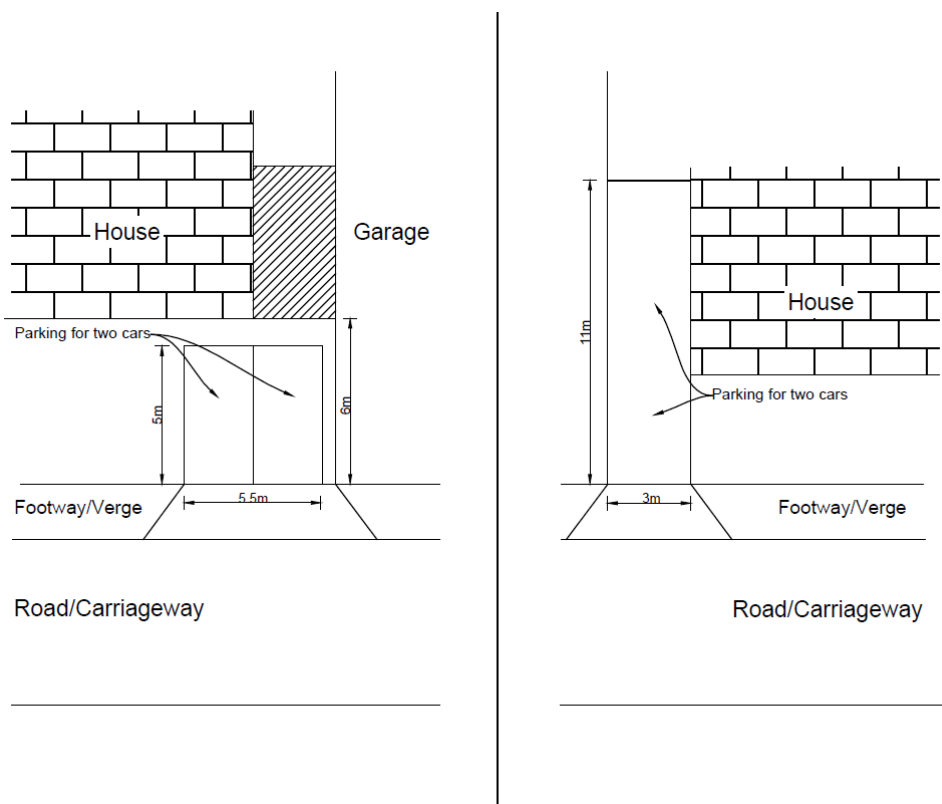

Figure 6.1 Private Garage/Car Port set-back arrangement and in curtilage parking dimensions

6.3.2.11 If visitor parking is being provided within the curtilage of individual properties then some allowance has to be made for on-street parking of service vehicles, e.g. mobile shops and delivery vehicles, which would not park in a driveway. Depending on the status of the road, its speed limit and volumes of traffic, there may be a need to provide service bay parking for such vehicles.

6.3.2.12 A hard surface shall be provided to the driveway for at least the first 6 metres from the heel of the footway. Where a driveway is level or slopes towards the public road, loose material, such as gravel, will not be permitted over this initial section, as this can spill onto the public road and cause a road safety hazard. A hard permeable surface would be preferred. Effective measures must also be taken to ensure that surface water does not discharge to or from the public road, via the driveway.

Note: For housing units with more than four bedrooms a higher level of in curtilage parking will be required.

6.3.3 ***Non-Residential Developments***

6.3.3.1 In industrial, commercial and shopping developments, parking provision will normally be in the form of large surface or multi-storey car parks. The actual car park layout will depend upon operational requirements, particularly where it is proposed to control entry and exit by means of barriers, with adequate space to be provided to ensure that any queues do not extend onto the public road.

6.3.3.2 Non-residential developments may need to provide for different types of parking, this being:-

- Operational parking – for those essential staff who use a vehicle during the day and also for service vehicles:
- Commuter parking – for staff, who drive to and from work; and
- Visitor parking – customers and other visitors.

6.3.3.3 Large unbroken expanses of parking can look unattractive and may also be confusing for drivers trying to find their vehicles. It is desirable for large parking areas to be subdivided, with the use of appropriate landscaping features, into units of between fifty and one hundred spaces. In such areas, footway widths should be maintained by the use of kerbs, bollards or other appropriate barrier.

6.3.3.4 Parking and loading areas should be sited close enough to buildings to discourage instances of indiscriminate parking by those drivers who want to avoid walking. However, wherever possible, access by sustainable modes of travel should be given priority over the private car. People will accept longer walking distances, if the environment is considered to be safe and pleasant, but with 400m normally an appropriate maximum distance.

6.3.3.5 If the need for coach parking is envisaged, as part of a development, its requirements should be taken into account as part of the design process.

6.3.3.6 *Retail developments* – vehicular parking will be required for customers, staff and service vehicles. For retail centres and shops in close proximity to each other, shared parking is encouraged, in order to reduce the total level of parking required. Where this is not feasible, attractive pedestrian links should be provided instead, to discourage motorists driving short distances from one shop to another.

6.3.3.7 The site layout of a retail development can significantly influence whether it is well accessed by public transport. This can affect the attractiveness of travelling by public transport, so the design needs to consider such a requirement early, in consultation with the Council and likely public transport operators.

6.3.3.8 *Industrial developments* – these will require staff and customer/visitor parking. It will also be essential to provide appropriate parking and servicing facilities for goods and service vehicles.

6.3.3.9 *Office developments* – these will require adequate staff parking, with some facilities for visitors and service needs. To reduce parking numbers, it is important that good public transport services operate, in order to meet the needs of staff. This is essential for business parks, where high numbers of staff could be travelling at similar periods.

6.3.3.10 *Leisure developments* – these developments, especially exhibition centres, stadia and theme parks, can generate very high levels of car and coach parking, which can be concentrated at particular periods. Public transport will be an essential requirement for such new developments.

6.3.3.11 *Internal Layout* - for large car parks, it is essential that an appropriate distance is provided between the junction with the public road and the first internal car park junction, to prevent vehicles entering the car park having to queue back onto the public road. This will be influenced by the form of access control and is especially relevant where barriers are provided.

6.3.3.12 For large developments or where there are significant flows of different transport modes, it is desirable, in the interests of road safety, to segregate road users by providing separate access points for customers, service traffic, public transport and, occasionally, employees.

6.3.4 ***Parking Bay Design***

6.3.4.1 *Bay sizes* - the minimum design dimensions for a parking bay for a car shall be 2.5m x 5.0m, unless agreed otherwise with the Council. Where appropriate, the Council may seek the provision of larger spaces.

6.3.4.2 Where a parking bay has a fence, wall or other obstruction along a longitudinal boundary, the width of the bay should be increased to 3m. Similarly, the length of bays with end walls or other

obstructions should be increased to 5.5 m. Where a private driveway is designed to provide end to end in curtilage parking for two cars, the minimum length of the driveway shall be 11 metres.

6.3.4.3 Where parking is parallel to the carriageway, the length of the bay should be increased to a minimum of 6 metres.

6.3.4.4 *Off-street parking areas* – typical layouts for off-street parking areas are shown in Figure 6.2. It should be noted that angled parking layouts tend to be less efficient in land-use than 90° parking layouts, even with the narrower aisle widths that are possible with single-way arrangements. However, the use of angle parking may be suitable on narrow sites.

6.3.4.5 Where the end of an aisle between two rows of 90° parking bays terminates with no vehicular access, then the aisle should be extended past the last two bays by a minimum of 1.5 metres in order to provide vehicles room to manoeuvre when leaving the bays.

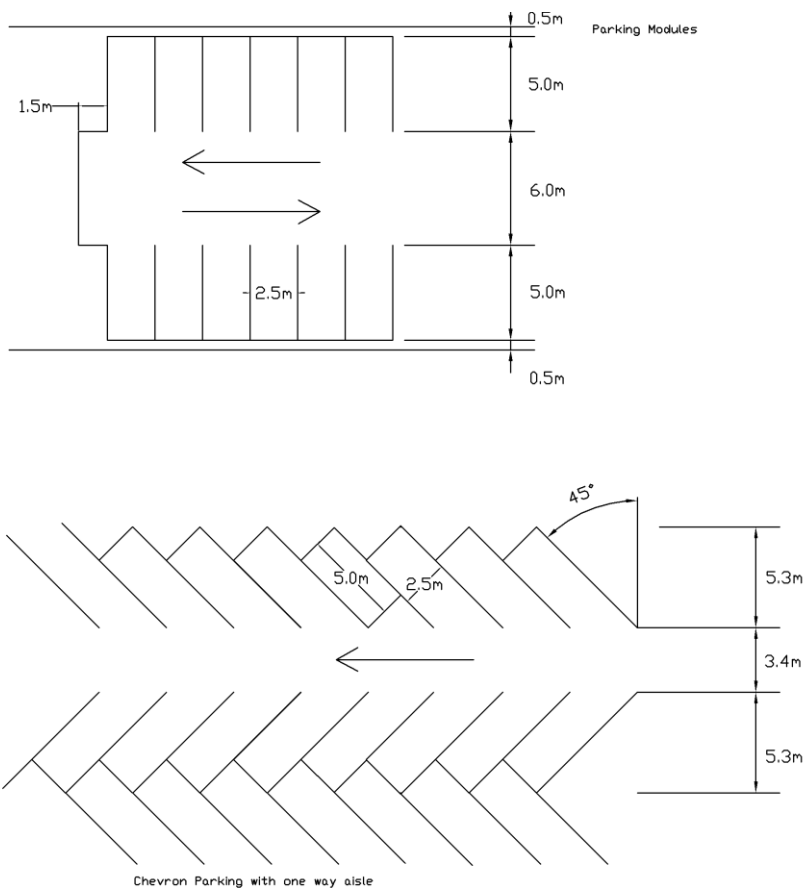

| Angle of Parking (degrees) | Aisle Width (w) (metres) |
|----------------------------|--------------------------|
| 30 | 3.2 |
| 45 | 3.4 |
| 60 | 4.0 |
| 75 | 4.7 |
| 90 | 6.0 |

(8m required for lock-ups)

Figure 6.2 Off-Street Parking Layouts

- 6.3.4.6 *On-street lay-by parking* – in some situations, it will be acceptable to provide some on-street parking spaces, which should normally be available for use by the general public. The layout of such lay-by parking areas will depend on the road type and flows of traffic. On Main Residential Streets, lay-by parking should comprise bays that are at least 6.0 metres long and 2.5 metres wide, positioned parallel to the carriageway, with 2.5 metre splays at either end. On lightly trafficked roads, deeper lay-bys may be provided to permit parking at right angles to the public road, although it should be noted that the Council may not permit such right angled parking where it is considered that the extra manoeuvring required could be detrimental to the road safety of passing traffic or impede free traffic flow.
- 6.3.4.7 On minor roads and streets, right angled bays are preferred to parallel parking bays, since the latter can be confused with passing places. In addition, shared surface roads should provide right angled parking rather than parallel parking, as this is considered to be a safer arrangement for pedestrians.
- 6.3.4.8 In residential areas, on-street parking bays should be laid out in a manner that minimises their use of public space, complement traffic calming objectives and be designed to integrate into the public environment. However, long lengths of parallel parking can appear monotonous, require long visibility splays and actually encourage faster vehicle speeds. In order to counter these impacts, parallel bays should be provided in groups of six spaces or less. The use of widened footways can help to break up lengths of parallel parking, whilst also providing areas for pedestrian crossing points and landscape areas. On-street parking bays should not be sited opposite junctions or those private accesses having significant flows of traffic. The Council would expect to adopt such parallel parking bays.
- 6.3.4.9 *On-street right angled parking* – Figures 6.3a and 3b show the layout of parking bays located at right angles to the carriageway. Public parking, (for example, for casual visitors) should be provided in groups of not less than four bays, located immediately adjacent to the carriageway (Figure 6.3a), with long groups of parking sub-divided into groups of between six and ten spaces, with appropriate landscaping and/or kerb build-outs. However, significant lengths of footways flanked by such end-on parking will be discouraged.
- 6.3.4.10 Private parking (for example, for residents) should be provided in groups of no more than three bays, located at the rear of the footway and taking access via a dropped kerb (Figure 6.3b). In shared surface locations, some definition between public and private parking bays must be provided. Such parking areas should be hard surfaced.
- 6.3.4.11 Where there are pedestrian areas, these should be protected from vehicle overhang by use of bollards or other devices.

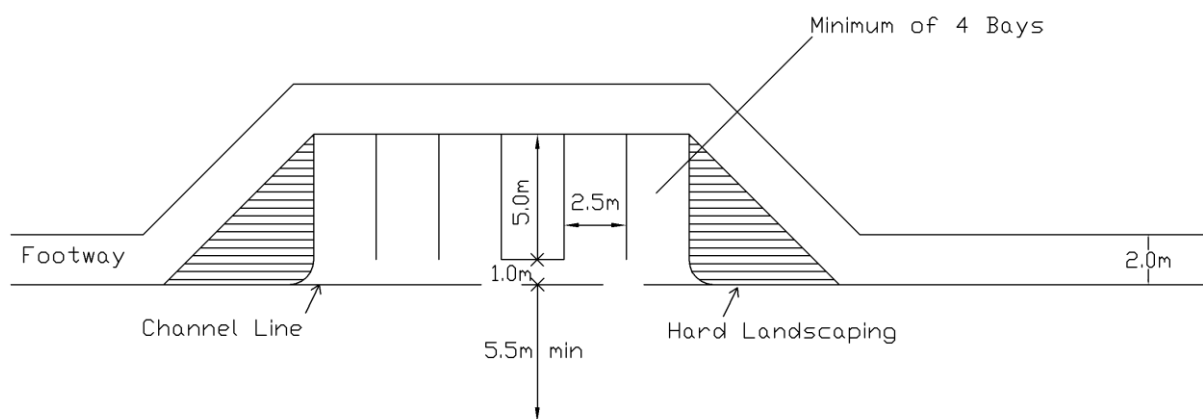

Figure 6.3a Public Parking Bays at Right Angles to a Road

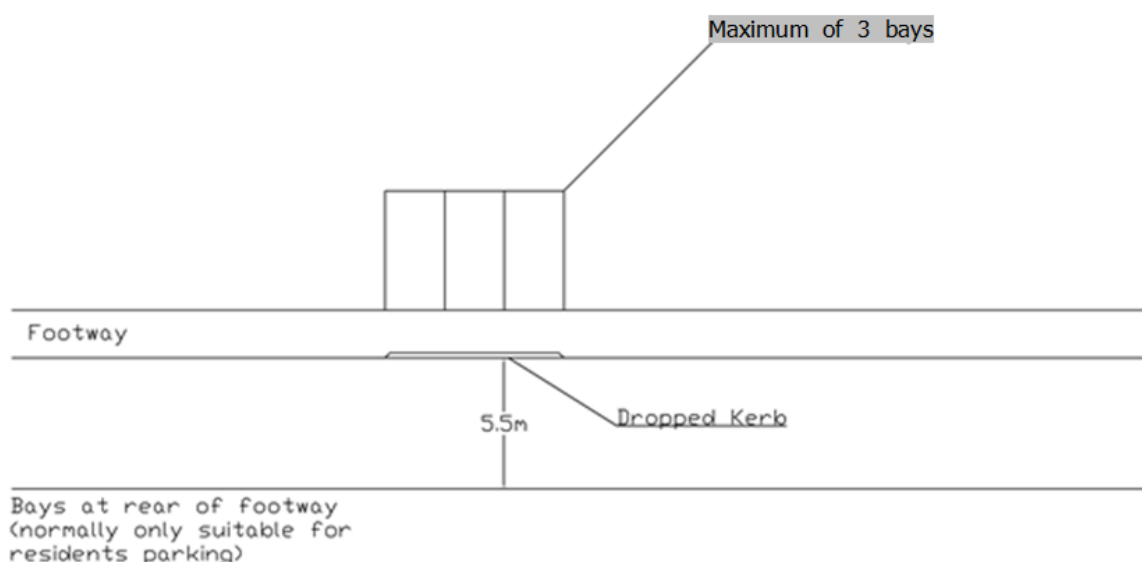

Figure 6.3b Private Parking Bays at Right Angles to a Road

6.3.5 Parking for Persons with Mobility Difficulties

6.3.5.1 *Disabled persons* - special consideration shall be given to the needs of disabled persons, with regard to the provision of parking bays, including their number, the locations/layout and the pedestrian routes to such bays.

6.3.5.2 **Inclusive Mobility** gives guidance on the proportion of parking spaces that should be provided for vehicles carrying disabled persons and on the design of these spaces. Approximately 5% of car parking should be reserved for disabled persons, with actual requirements set out in Table 6.11.

6.3.5.3 Parking spaces suitable for disabled persons should be sited on level areas, with little or no crossfall, being as close as practical to any amenities and certainly no more than **45 metres** from the main entrance of a building. Desirable layouts for both on-street and off-street accessible parking bays are shown in Figure 6.4 and are based on the requirements of the Building Regulations. For economy of space, it is best to provide pairs of spaces, rather than isolated single ones. Where room is available, the 3.6m wide parallel bays should be provided, but in some locations, particularly quiet streets, a narrower width (but no less than 1.8m on-street) may be acceptable to the Council. Full details are can be found in Appendix 12.

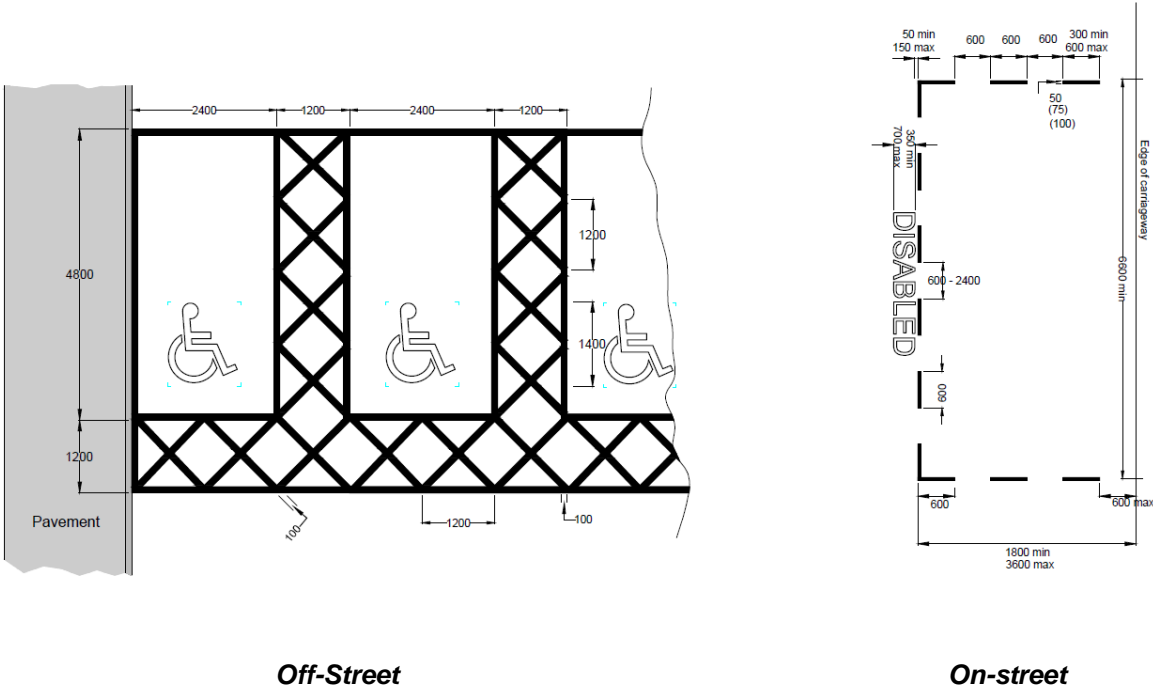

Figure 6.4 Parking Spaces for Disabled Persons (desirable markings)

6.3.5.4 In October 2009, the Scottish Government introduced the **Disabled Persons’ Parking Places (Scotland) Act 2009** to help prevent abuse of disabled persons’ parking spaces. The Act requires all on-street disabled persons’ parking spaces to be the subject of associated TROs. This requirement also applies to Council-controlled off-street car parks. In addition, the Act encourages those off-street private parking spaces allocated for disabled persons, provided within a development site, to also be subject to TROs and the potential for this should be discussed with the Council at an early stage. A developer would be expected to pay the cost of implementation of such a TRO.

6.3.5.5 *Parent and child parking* – the Council will seek, where appropriate, the provision of allocated “parent and child” parking, especially for retail developments, at the same ratio as for disabled persons.

6.3.6 Cycle Parking

6.3.6.1 Cycle parking, within developments, should be sited as close as possible to the main entrances of the facility being served, be well lit and signed and must not be hidden out of sight. It must be easily accessible for cyclists arriving from adjacent roads and cycle routes.

6.3.6.2 The Council will expect secure cycle parking facilities to be installed at shopping, transport and other communal centres where significant cycle usage is anticipated or to be encouraged. Generally, the suitable methods of secure short term parking are:-

- Rack stands
- Rail or guard rail
- Wall bracket
- Cycle locker

6.3.6.3 For short term cycling parking, the Council's preference is the provision of rack stands. Recommended dimensions and spacings are shown in Figure 6.5.

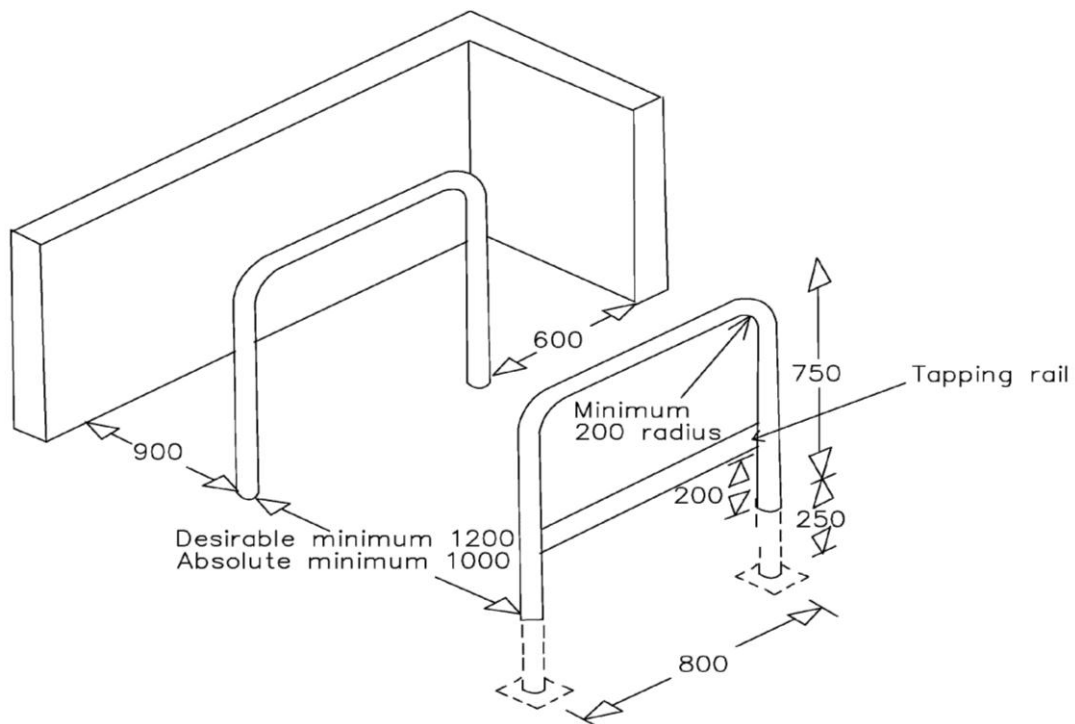

Note : All dimensions are in millimetres

Figure 6.5 Cycle Rack Stands – Typical Dimensions and Spacings

- 6.3.6.4 For private houses, it would be expected that suitable cycle storage would be provided either within a garage, within the house or in a shed in a secure rear garden. For flatted developments, designs must examine the provision of an internal cycle storage facility for each flat unit. These could be an individual storage area within each flat or provided as a communal facility, as an integral part of the main building. The provision of an external facility, solely for the storage of bicycles is not recommended, as these tend to be located in positions that are isolated from the main buildings and are often not very visible and, therefore, not secure, unless a cycle parking facility can be included within secure vehicular parking areas.
- 6.3.6.5 For the majority of all development types, staff cycle parking should be provided in a secure and covered area. Cycle parking for visitors and customers should be located close to the main building entrance and, preferably, be covered. Where visitors/customers need medium or long term parking, secure facilities should be provided.
- 6.3.6.6 For more guidance and information, reference should be made to **Cycling by Design**. In addition, **LTN 2/08 - Cycle Infrastructure Design** is also useful.

6.3.7 **Motorcycle Parking**

- 6.3.7.1 Where it is expected that there will be a demand for motorcycle parking, such as at major retail and employment developments, consideration should be given to the provision of designated parking areas solely for the use of motorcycles. The majority of motorcycles have effective lengths and widths of approximately 2 metres and 1 metre, respectively. Hence, if an individual bay is provided, it should have minimum dimensions of 1.3 metres by 2.3 metres. However, it is recommended that parking is provided in groups, with area marked out but not individual bays, as this provides (a) security in numbers of vehicles and (b) more efficient use of space.
- 6.3.7.2 Parking for employees should be covered and have a rack or other suitable fixture to which the motorcycle can be locked. The rack must also be secured to the ground. For visitors and customers, where a medium to long stay is expected, the provision of secure and covered facilities should also be provided. Short stay parking should still have designated bays, to avoid indiscriminate parking.

6.4 Parking Standards / *Inbhean Parcaidh*

6.4.1 *Introduction*

6.4.1.1 The parking standards set out in this document are generally expressed as maximum standards. Only for residential developments, cycle, motorcycle and disabled persons' parking are minimum standards specified.

6.4.1.2 *Assessment of parking* - it should be recognised that developments will be affected by a range of factors, such as type of development, location, accessibility to sustainable modes of travel, proximity to other facilities and size of development, etc. **For most new developments the Council will usually require parking to be provided at or close to the maximum standards set out in the following tables unless it can be demonstrated by an assessment of parking requirements or by the proximity of the development to public parking, for example within a town centre, that lower levels of parking are acceptable. However, in certain circumstances the Council may encourage or require lower levels of parking.**

6.4.1.3 For those developments where a TA is required, this must include an assessment of parking requirements and provide justification of the proposed parking levels. For those developments that do not require a TA, it is still desirable that a Parking Statement be submitted, as part of the planning application, clarifying proposed parking provision and how it compares with the Council's standards.

6.4.1.4 *Rural locations* - the Council area includes many rural locations where levels of public transport provision are low and there may be instances where a developer and/or the Council consider that the prescribed maximum levels of parking may need to be exceeded, in order to accommodate higher numbers of vehicles generated by larger catchment areas.

6.4.1.5 *Town centre parking and commuted payments* – within existing town centres, the Council recognises that new development and redevelopment can help to maintain or enhance the economic viability of these town centres. However, it is often the case that parking levels, complying with the parking standards, cannot be provided because of lack of space. In such situations, each application will be assessed on merit and may be recommended for approval but subject to the developer being required to provide a commuted payment in lieu of the parking (being additional to any other financial contributions deemed appropriate for the development).

6.4.1.6 *Management of car parks* – where a development results in off-street parking areas with more than 100 spaces, the developer must agree a management plan with the Council. In some circumstances, a management plan may also be required for car parks with less than 100 spaces, where its impact is deemed to be significant.

6.4.1.7 *Controlled Parking Zones* – the application of parking levels that help to address unrestricted vehicular trip generation and encourage sustainable travel may, in certain circumstances, lead to some indiscriminate parking on adjacent public roads. In such situations, a developer may be

required to fund the introduction of Traffic Regulation Orders for the introduction or extensions of Controlled Parking Zones, together with associated physical measures, to address such problems.

6.4.2 **Parking Standards Tables**

6.4.2.1 *Parking Levels* – guidance on parking standards are set out in various tables as listed below:-

| | |
|--|------------|
| Residential Developments | Table 6.1 |
| Healthcare, Education and Community Developments | Table 6.2 |
| Leisure Developments | Table 6.3 |
| Hotels, Restaurants/Cafes, Pubs and Function Rooms | Table 6.4 |
| Places of Assembly | Table 6.5 |
| Retail | Table 6.6 |
| Commercial/Industrial | Table 6.7 |
| Motor trade | Table 6.8 |
| Cycle Parking | Table 6.9 |
| Motorcycle Parking | Table 6.10 |
| Car parking for disabled persons | Table 6.11 |

6.4.2.2 Where a particular type of development is not included in any of the tables, parking levels shall be assessed on an individual basis and agreed with the Council.

6.4.2.3 *Mixed Use Developments* – parking levels for developments that are of mixed use should generally be assessed on merit, as there are likely to be opportunities to share parking, as a result of shared car trips and/or different peak parking requirements.

6.4.2.4 *Shift Patterns* – for those developments where there may be employment shift patterns or where groups of people arrive prior to the departure of other groups, then special consideration needs to be given to the appropriate level of parking and its design. In such instances, early discussion with the Council is recommended.

6.4.2.5 *Coach Parking* – for some types of development, coach parking can be a significant issue that will require to be considered in detail, in terms of access and parking requirements. For example, coach sizes vary significantly, which will influence the dimensions of bays.

6.4.2.6 *Taxi Stands* - for developments which meet the Council's criteria for a Transport Assessment or Travel Plan, a taxi pick up/set down point should be provided close to the main entrance to the building(s). Link routes to the building entrance should conform to general guidance for the accessibility needs of disabled persons and their accessibility to building entrances.

Table 6.1 Residential Developments

| Residential Development Type | <u>Minimum</u> car parking spaces per unit, including visitor spaces, unless otherwise indicated |
|--|--|
| General Housing Includes Private, Housing Association and Council Housing | Note: in curtilage parking levels are based on units not exceeding 6 bedrooms. For larger units, see Note 1 below. |
| Housing with parking within curtilage for residents | Up to 4 no. bedrooms - 2.0 external spaces 5 no. or 6no. bedrooms – 3.0 external spaces |
| plus visitor parking (communal, may be on-street) | 0.3 |
| Houses and flats with communal parking for residents | 1.2 |
| plus visitor parking (communal, may be on-street) | 0.3 |
| Redevelopment in Town Centres | Assessed on merit (see Note 4) |
| Sheltered Housing | 0.5 plus 1 per resident staff |
| Residential Homes for the Elderly | 0.3 per bed plus 1 per staff |
| Children’s Homes | 1.5 per 2 staff |
| Hostels | 1.5 per 2 staff |
| Homes in Multiple Occupancy | Assessed on merit |

Notes

1. For general housing units with more than six bedrooms, higher levels of car parking would be expected.
2. The design of layouts should allow for on-street communal parking, especially for visitors.
3. Where housing units provide a garage within the curtilage of each property, the parking space provided by a single garage would not be counted towards the minimum parking provision; however, a double garage of minimum dimensions 5.5 metres x 6 metres would be counted as one parking space.
4. For residential developments in town centres, the Council may accept reduced parking provision in certain circumstances if it can be demonstrated to comply with Council policy.
5. For Sheltered Housing, Residential Homes, Children’s Homes and Hostels, staff are classed as either “residential staff”, who live on the premises, or “non-residential staff”, who only work at the premises. Parking spaces per staff relate to the number of staff on site at any one period, rather than the total number of employed staff.

Table 6.2 Healthcare, Education and Community Developments

| Development Type | Maximum Parking Levels as specified |
|--|--|
| Hospitals | Assessed on merit (see Note 1) |
| Health Centres | 5 spaces per consulting room Additional parking for staff may be needed if additional services are provided |
| Schools (See Note 2) | 1 space per staff plus visitor parking plus coach provision |
| Colleges and Universities (See Note 3) | Generally 1 space per 2 staff plus 1 space per 15 students |
| Libraries | 3 spaces per 100m ² PFA plus 1 space per 2 staff In addition, a space for a mobile library van |
| Community Centres | 20 spaces per 100m ² PFA |
| Tourist Information Centres | 5 spaces per 100m ² PFA (See Note 5) plus 1 space per staff |

Notes

1. Hospital developments, including expansions of existing facilities, will be assessed on merit, taking account of possible scale of development, different types of medical services and likely catchment areas. Staff shift patterns are likely to have a significant impact on parking levels. Such developments are likely to be subject to a Transport Assessment.

2. For schools, the provision of adequate coach parking will be required. In addition, a Drop Off/Pick Up Management Plan will be required to be submitted for approval by the Council, as supporting information for the planning application. Where a school also provides community facilities for the public, a Parking Management Strategy Plan will be required, setting out how such public parking will be provided and managed, as part of the planning application.

3. Colleges and Universities, including expansions of existing facilities, will be assessed on merit and be subject to a Transport Assessment, although the above standards will apply as maximum levels unless increased parking can be suitably justified.

4. The standard for students relates to the total number of students attending an educational establishment, rather than full-time equivalents.

5. Where a Tourist Information Centre is located within a town centre zero parking is acceptable where alternative public parking is available nearby.

6. For healthcare, education and community developments in town centres, the Council may accept reduced parking provision in certain circumstances, if it can be demonstrated to comply with Council policy.

Table 6.3 Leisure Developments

| Development Type | Maximum Parking Levels as specified |
|---------------------------------|--|
| Swimming Pools | 10 public spaces per 100m ² pool plus 1 space per 3 staff, at peak times |
| Snooker Halls | 1 public space per table plus 1 space per 3 staff |
| Tennis/Squash Courts | 2 public spaces per court plus 1 space per 3 staff, at peak times |
| Golf Clubs | 2 spaces per hole plus 1 space per 3 staff |
| Marinas | 2 space per berth plus 1 space per 2 staff |
| Gymnasium | 5 spaces per 100m ² public floor area plus 1 space per 3 staff |
| Stadia | 1 space per 15 seats (See Note 3) |
| Garden Allotments | Assessed on merit (See Note 5) |
| Other Leisure Facilities | Assessed on merit |

Notes

1. The above car parking levels may differ from SPP levels for those developments where the threshold for the application of SPP applies, given the different criteria used. In such cases, the developer must justify the proposed level of parking, if the number of spaces is likely to exceed current national maximum standards, and agree it with the Council.

2. The above standards are maximum levels and the Council would encourage lower levels to be provided, especially where accessibility to sustainable modes of transport, particularly public transport, is good or where developments are located within or close to town centres.

3. All stadia proposals will require a Transport Assessment, with the above standards providing a guide on maximum levels. Stadia will also require significant coach parking, which would need to be managed and controlled, in order to prevent their spaces being used by cars.

4. For leisure developments in town centres, the Council may accept reduced parking provision in certain circumstances, if it can be demonstrated to comply with Council policy.

5. For garden allotments, further guidance is contained within the Council's Allotment Policy, available via the following link.

<http://www.highland.gov.uk/NR/rdonlyres/C71A8822-7DAC-4588-A749-2483EFBFEB70/0/AllotmentPolicyv2.pdf>

Table 6.4 Hotels, Restaurants/Cafes, Pubs and Function Rooms

| Development Type | Maximum Parking Levels per m² public floor area (PFA) or as otherwise specified |
|--|---|
| Hotel (bedrooms and residents' facilities only) | 1 space per bedroom plus 1 space per 3 staff |
| Hotel with conference facilities | Assessed on merit (See Note 2) |
| Public Bars | 1 space per 10m ² PFA plus 1 space per 3 staff |
| Restaurants and Cafes | 1 space per 5m ² PFA plus 1 space per 3 staff |
| Function Rooms | 1 space per 10m ² PFA plus 1 space per staff |

Notes

1. For hotels, details of proposed drop off/pick up arrangements by coaches shall be detailed within a Vehicle Management Plan, which must be approved by the Council and submitted as supporting information as part of the planning application. Only for large hotels, with over 100 bedrooms, would such coach parking need to be provided on site. For town centre sites or other locations, where the provision of on-site coach parking is not feasible, the Vehicle Management Plan must detail proposed external vehicle parking arrangements.
2. Hotels with conference facilities shall be assessed on merit, as conference facilities can generate significant volumes of car trips, which can be concentrated at certain periods. The accessibility of high quality public transport services can significantly influence the number of car spaces required.
3. For all types of developments, as specified in Table 6.4, that are proposed within town centres, the Council may accept reduced parking provision in certain circumstances, if it can be demonstrated to comply with Council policy.

Table 6.5 Places of Assembly

| Development Type | Maximum Parking Levels per seat or as otherwise specified |
|----------------------------------|--|
| Conference Centres | 1 space per 5 seats (See Note 1) |
| Theatre and Concert Halls | 1 space per 5 seats |
| Cinemas | 1 space per 5 seats |
| Bingo Halls | 1 space per 5 seats |
| Churches | 1 space per 5 seats |
| Church Halls | 20 spaces per 100m ² GFA |

Notes

1. *Conference centres should be assessed on merit, as they can generate significant volumes of car trips, which can be concentrated at certain periods. The accessibility of high quality public transport services can significantly influence the number of car spaces required.*

2. *For all types of developments, as specified in Table 6.5, that are proposed within town centres, the Council may accept reduced parking provision in certain circumstances, if it can be demonstrated to comply with Council policy.*

Table 6.6 Retail Developments

| Development Type | Maximum Parking Levels per stated m² Gross Floor Area (GFA) or as otherwise specified |
|---|---|
| Food Shops | 1 space per 14m ² GFA |
| Food Superstores | 1 space per 14m ² GFA (See Note 1) |
| Non-Food Shops | 1 space per 20m ² GFA |
| Retail Parks | Assessed on merit (See Note 2) |
| Markets (open) | 1 customer space per 100m ² GFA plus 1 staff space per stall/pitch |
| Garden Centres | 1 customer space per 20m ² GFA plus 1 space per 3 staff |
| Retail Redevelopment within Town Centres | Assessed on merit (See Note 5) |

Notes

1. All food superstores (which shall include supermarkets, hypermarkets and discount stores) shall be assessed on merit. Whilst the above standards will act as the maximum levels, acceptable parking levels are to be justified within a Transport Assessment.
2. Parking levels for retail parks shall be assessed on merit, taking account of potential shared trips that should result in a lower parking level than for individual retail units.
3. The design of the layout for retail developments, including facilities for sustainable modes of travel, will be critical elements that can significantly affect the levels of required car parking. Where retail facilities are close to each other, attractive pedestrian routes should be provided, in order to encourage customers to walk between units rather than drive.
4. The above maximum parking levels will apply within urban areas. For large retail developments located within rural areas, Transport Assessments need to justify parking levels. The above standards will act as a guide, but higher levels of parking may be deemed appropriate/necessary for rural locations, due to likely larger catchment areas and lower levels of public transport service.
5. Extensions to existing developments and also retail redevelopment proposals within town centres will be assessed on merit and the Council may accept reduced parking provision in certain circumstances, if it can be demonstrated to comply with Council policy.
6. Where a retail development car park is designed to provide general town centre parking or can be demonstrated to do so to a significant extent then that can be recognised in the amount of parking that is permitted, especially if above the levels specifically allowed for the development. Such additional parking must be agreed with the Council.

Table 6.7 Commercial/Industrial Developments

| Development Type | Maximum Parking Levels per stated m² Gross Floor Area (GFA) or as otherwise specified |
|--|--|
| Offices | 1 space per 30m ² GFA |
| Business Parks | Assessed on merit (see Note 1) |
| General Industry, factories and workshops | Town centres – 1 space per 50m ² GFA Edge of town – 1 space per 33m ² GFA Rural locations – 1 space per 20m ² GFA |
| Non-food warehouse (trade) | 1 space per 50m ² GFA |
| Storage/Distribution (non-sales) | 1 space per 100m ² GFA |
| Banks | 1 customer space per 33m ² GFA plus 1 space per 2 staff plus suitable area for security van |

Notes

1. *Business parks shall be assessed on merit and be subject to a Transport Assessment.*
2. *Developments, including extensions to existing developments and also redevelopment proposals, within town centres will be assessed on merit and the Council may accept reduced parking provision in certain circumstances, if it can be demonstrated to comply with Council policy.*

Table 6.8 Motor Trade Developments

| Development Type | Maximum Parking Levels per stated m² Gross Floor Area or as otherwise specified |
|---------------------------------|---|
| Vehicle Display Area | 1 customer space per 30m ² GFA plus 1 space per 2 staff |
| Spares Department | 1 customer space per 25m ² GFA plus 1 space per 2 staff |
| Servicing/Repairs | 4 customer spaces per service bay plus 1 space per 2 staff |
| Tyre and Exhaust Centres | 2 customer spaces per service bay plus 1 space per 2 staff |
| Car Wash | 6 queuing spaces plus 1 space per 2 staff |
| Scrap-yards | 1 customer space per 50m ² GFA plus 1 space per 2 staff |

Notes

1. *Parking requirements for vehicle display areas are for customers and staff and should be marked accordingly. Sufficient additional spaces for the storage of show vehicles must be provided, with the parking of such vehicles on the public road being unacceptable.*
2. *For all motor trade activities, sufficient operational space must be provided, including areas for delivery and service vehicles.*
3. *For developments in town centres, the Council may accept reduced parking provision in certain circumstances, if it can be demonstrated to comply with Council policy.*

Table 6.9 Cycle Parking

| Category of Development | Type | Minimum Recommended Cycle Parking Provision (See Note 1) |
|--------------------------------|---|---|
| Residential | Flats | 2 spaces per flat provided within secure enclosed storage facility. May be reduced to 1 space per flat where communal storage is provided. 1 visitor space per 10 flats outside/near main entrance |
| | Houses | None specified where garage or private rear garden provided |
| Offices | All Types | 2 spaces plus 1 space per 250m ² GFA |
| Industry | All Types | 2 spaces plus 1 space per 250m ² GFA |
| Retail | All Types | 1 space per 8 car parking spaces |
| Educational | Primary and Secondary Schools | 1 space per 20 staff 1 space per 10 pupils |
| | Colleges and Universities | 1 space per 20 staff 1 space per 10 students |
| | Student Flats/Halls of Residence | 1 space per 4 staff and students |
| Recreational | General | 1 space per 8 parking spaces |
| Community | Hospitals | 1 space per 8 parking spaces |
| | Health Centres | 1 space per 8 parking spaces |
| | Churches and Community Centres | 1 space per 8 parking spaces |
| | Libraries | 1 space per 8 parking spaces |
| Transport | Railway Station | 5 spaces per number of trains during peak period |
| | Bus Station | 2 spaces per 100 passengers during peak period |
| Other | Other Types not covered | Assessed on merit |

Notes

1. The level of cycle parking provided for a particular development will be influenced by whether the site is within an urban or rural location. An urban location, particularly one that is well connected to external cycle routes, would usually justify higher cycle parking provision than a more rural location. The actual cycle parking levels for a development, including provision for visitors, are to be agreed with the Council.
2. For large developments where the standards may result in large numbers of staff cycle parking, which are provided in communal facilities, the Council may initially relax the number of spaces provided, as long as there was agreement that cycle use would be regularly surveyed, as part of the Travel Plan monitoring process, with additional spaces provided to meet subsequent increased demand.
3. The type of cycle parking facilities that a developer proposes to provide must be agreed in advance with the Council.

Table 6.10 Motorcycle Parking

| Development Type | <u>Minimum</u> Recommended Motorcycle Parking Provision |
|-------------------------|---|
| Residential | Flats – 1 secure and covered space per 20 units Houses – none specified where garage or private rear garden provided |
| Industrial | 1 space per 50 car parking spaces, with at least 1 space provided |
| Retail | 1 space per 50 car parking spaces, with at least 1 space provided |
| Offices | 1 space per 50 car parking spaces, with at least 1 space provided |
| Recreational | 1 space per 25 car parking spaces, with at least 1 space provided |

Notes

1. Long term parking shall be covered and secure, especially for staff. Short term parking should be located close to building entrances and, preferably, should allow a motorcycle to be attached to a secure fixing.

Table 6.11 Car Parking for Disabled Persons – Minimum Requirements

| | <i>Car park maximum standard size up to 200 spaces</i> | <i>Car park maximum standard size over 200 spaces</i> |
|--|--|--|
| Employment Uses | To be based on an assessment of need. Minimum 1 space per disabled employee plus 1 space or 5% of maximum standard size, whichever is the greater | 6 spaces plus 2% of maximum standard size |
| Retail, Leisure and Recreation Uses | To be based on an assessment of need. Minimum 1 space for car parks up to 20 spaces and for larger car parks minimum of 2 spaces or 6% of maximum standard size, whichever is the greater | 4 spaces plus 4% of maximum standard size |

Notes

1. *The specific parking for disabled persons is considered to be part of the total number of car parking spaces, rather than in addition.*
2. *Spaces for disabled persons must be located closer to building entrances than general spaces. Pedestrian facilities, suitable for disabled persons, shall be provided from the allocated spaces to the main pedestrian areas.*
3. *Where “parent and child” spaces are also deemed appropriate, these should be provided at the same ratio as per disabled spaces, unless agreed otherwise with the Council.*
4. *All disabled persons’ parking spaces provided on-street or within Council-controlled off-street car parks shall be subject to a TRO. For private off-street parking areas, the Council will encourage developers to agree to the promotion of a TRO to control the disabled persons’ parking spaces.*

CHAPTER 7 – CONSTRUCTION MATERIALS STANDARDS / CAIBIDEAL 7 – INBHEAN STUTHAN

TOGAIL

7.1 General / Coitcheann

- 7.1.1 The Council’s objective, with regard to construction materials standards, is to achieve finished works at reasonable cost using durable materials requiring minimal and easy future maintenance. The specifications for construction works shall be in accordance with the **Manual of Contract Documents for Highway Works Volume 1: Specification for Highway Works** (referred to as the Specification), published by TSO (The Stationary Office), and any supplements or revisions as issued and as amended by these guidelines. Clause references mentioned within this document relate to the Specification. Adherence to the Specification, as amended by these guidelines, will be an important consideration in recommending any new road for adoption. Where a Specification clause refers to an associated Appendix for further information then clarification should be sought from the Council.
- 7.1.2 The **Specification** is closely linked with the **DMRB** that provides a comprehensive manual system (now in CD format) accommodating all current standards, advice notes and other published documents relating to the design, assessment and operation of trunk roads. However, a lot of guidance provided in the DMRB is also relevant to the design of local roads.
- 7.1.3 The use of re-cycled or newly developed materials, together with non-standard design details, is not precluded, but such proposals must be discussed and approved by the Council before their inclusion in any proposals subsequently submitted for formal approval. A developer should note acceptance of such materials for Road Construction Consent and subsequent adoption will be at the discretion of the Council and normally only works of a limited extent will be accepted on an experimental basis until techniques and materials have been tested through time.
- 7.1.4 Earlier Chapters have already stressed the importance of early and full consultation in relation to geometric design and layout. This advice applies equally to construction standards and the developer should discuss standards with the Council. This is especially important for those sites with drainage problems, soils with low CBR or soils susceptible to frost heave.
- 7.1.5 Taking account of the above points, proposed schemes should be designed from the outset with the final construction phase in mind, with the objective of seeking to minimise disruption to existing infrastructure and the local community. Consideration should be given to the phasing of permanent and temporary works. A Construction Method Statement will normally be required to be submitted as part of the Road Construction Consent Application.

7.2 Geotechnical Requirements

- 7.2.1 The extent and type of ground investigation requirements, with associated detailed documentation, will be dictated by the nature of the proposed development, the site’s previous land use(s) and local ground conditions.

- 7.2.2 All ground investigation reports should comply with **BS 5930: Code of Practice for Site Investigation**. The Factual Ground Investigation Report should include the following information, as a minimum:-
- exploratory borehole/trial pit logs;
 - laboratory test data, being relevant to the proposed form of road construction;
 - site plan, at 1/500 scale, showing the proposed road layout and all borehole/trial pit locations.
- 7.2.3 The spacing of the boreholes/trial pits will depend upon the nature of ground conditions and the proposed development. Sufficient and appropriate locations shall be chosen to ensure the condition of the site can be fully identified.
- 7.2.4 Where it is proposed to construct a new road on land previously used for industrial purposes or waste disposal, chemical analysis data and gas monitoring information must be submitted, in addition to standard test data. Further relevant information is contained within **BS 10175: Investigation of Potentially Contaminated Sites – Code of Practice**.
- 7.2.5 The Ground Investigation Interpretive Report must be submitted with the Road Construction Consent application.
- 7.2.6 *California Bearing Ratio (CBR)* – the CBR value of the soil shall be determined by the laboratory CBR test in accordance with **BS 1377: Part 4 Methods of Test for Soils for Civil Engineering Purposes**. Test results shall be incorporated in the Factual Ground Investigation Report.

7.3 Road Drainage

- 7.3.1 *Road Gullies* - road gullies must be constructed in accordance with Clause 508 of the Specification and fitted with external traps. Gully pots should be either 450mm inside diameter (I.D.) precast concrete or 450/510mm I.D. in-situ concrete with plastic former. Gratings shall be set to level and grade on two courses of engineering brick. Gully gratings and frames shall be Class D400 complying with **BS EN 124 Gully Tops and Manhole Tops for Vehicular and Pedestrian Areas** and be of a size compatible with the gully pot. The gully frame is to be 100mm deep and the grating is to be set 6mm below the road surface. Dished gullies should not be used. In non-contiguous car parks, Class C250 gratings and frames will be an acceptable alternative.
- 7.3.2 *Connections* - gully connections shall be constructed in accordance with Clause 508 of the Specification.
- 7.3.3 Where gullies are to be connected to a surface water drain, this shall be by means of 150mm diameter jointed fire-clay or plastic pipes, surrounded with 150mm of Class ST1 concrete where the cover is less than 0.9 metres.

- 7.3.4 Where a land drain is to be connected to the surface water drain, it must be via a silt trap.
- 7.3.5 *Chambers* - chambers should be constructed in accordance with Clause 507 of the Specification. Manhole covers and frames shall be non-rock types and comply with **BS EN 124** and be Class D400 (minimum clear opening 600mm diameter or equivalent, minimum depth of frame 100mm) except in non contiguous car parks or verges where the use of Class C250 (minimum clear opening 600mm diameter or equivalent, minimum depth of frame 100mm) will be permissible. Class B125 will only be permissible where no vehicle overrun is possible, for example where it is prevented by bollards.
- 7.3.6 All manhole covers should be positioned so they open in a manner that allows a person unobscured views of oncoming traffic when entering or exiting the manholes.
- 7.3.7 *Pipework* - all pipework combinations for road drainage must be in accordance with Volume 4, Section 2, Part 5, **HA 40** of the **DMRB** and constructed in accordance with the Specification.
- 7.3.8 *Down Pipes* - in redevelopment areas, there may be existing down pipes that may have previously discharged over the footway or through a footway channel. These must now be connected either directly into a gully pot or its connection with 100mm jointed pvc or fire-clay pipes. Permission will be required from Scottish Water and SEPA for this form of surface water treatment.

7.4 Pavement Construction

7.4.1 Carriageways

- 7.4.1.1 *Specification* - carriageway pavements for Strategic Route Roads and Main Distributor Roads shall be designed in accordance with Volume 7 of the **DMRB**. All other types of road shall be designed in accordance with the principles set out in Table 7.1, unless agreed otherwise with the Council.
- 7.4.1.2 Rigid pavement construction will not normally be accepted, except for individual accesses to industrial or commercial buildings.
- 7.4.1.3 *Design Life* – carriageway pavements for all prospectively adoptable roads other than a road classed as a Strategic Route or Main Distributor shall be designed for a 40-year life and a minimum construction required to carry 1.0 million standard axles for any road, unless agreed otherwise with the Council.
- 7.4.1.4 *Frost susceptible material* – in general, most soils in the Highlands region are frost susceptible and, as a result, a minimum construction depth of 450mm of non-frost susceptible materials should be used in the road construction, unless agreed otherwise with the Council. **If necessary, the thickness of sub-base should be increased (or used in place of capping) to ensure the minimum depth of non-frost susceptible material.**

7.4.1.5 *Formation/Sub-grade* – a sub-base thickness of 200mm is generally acceptable, based on a CBR of 15% or higher. Where the CBR is less than 15%, then the sub-base thickness needs to be increased or a capping layer provided underneath. As a guide, the following should be adopted for different sub-grade CBR values, unless agreed otherwise:-

| | |
|-----------|--|
| CBR =10% | 180mm sub-base + separate capping layer of 180mm |
| CBR = 5% | 240mm sub-base + separate capping layer of 210mm |
| CBR =2.5% | 350mm sub-base + separate capping layer of 250mm |

7.4.1.6 For an increased sub-base thickness, the minimum permitted CBR for the sub-grade is 2.5%. Where a sub-grade has a lower CBR, the increased sub-base is considered unsuitable support for a pavement foundation since it would tend to deform under construction traffic. It must, therefore, be improved using one of the following options:-

- The material at the surface can be removed and replaced by a more suitable material. If the depth of relatively soft material is small, all can be replaced but it may only be necessary to replace the top layer. The thickness removed will typically be between 0.5 - 1.0 metres.
- Use of an appropriate geotextile membrane system.
- If the soil is cohesive, a lime treatment may be appropriate, subject to soil suitability being demonstrated.
- If the soil is permeable, a deeper than normal drainage system may be considered, together with a system of monitoring the improvement expected.

7.4.1.7 Soft clays, saturated silts and running sand should normally be removed from below the pavement if practical. If not, measures as described above should be used to improve the sub-grade. Peat should also be removed, unless alternative construction methods are agreed with the Council. The presence of ground and surface water will not allow an economic foundation to be formed and, therefore, the sub-grade must be adequately protected and drained before construction commences to prevent ingress of water. The inverts of side ditches or filter drains must be at least 600mm below formation level or sub-formation level as appropriate. Replacement of unsuitable materials is best effected by free-draining sands and gravel or crushed rock. If sub-grade drainage is not possible then replacement should be with rock fill. On soft sub-grades, the foundation materials may penetrate the subsoil leading to uneconomic construction and a separation layer, using a geotextile fabric membrane, suitable for the soil type is advisable. The Council may also consider the use of recycled materials such as crushed concrete as capping material.

7.4.1.8 For new or extended roads totalling a length of less than 100m, it is unlikely that varying the capping layer thicknesses to suit different CBR values would be economical.

7.4.1.9 *Formation on rock* - where the formation is on rock, the granular sub-base can act as a 150mm deep regulating layer.

7.4.1.10 *Sub-base* - the sub-base is provided as a stable lower layer within the pavement construction. Sub-bases shall comply with Clause 803 of the Specification. Sub-base thicknesses are determined by the strength of the sub-grade, which is determined by the CBR Test. There are variants on the CBR Test - laboratory, field, with surcharge, saturated etc. In the context of this document, the laboratory CBR with a surcharge to simulate the appropriate vertical overburden stress of the case being considered should be taken as the standard method, unless another method of testing is agreed with the Council.

7.4.1.11 *Base* – dense base and binder course asphalt concrete shall comply with Clause 906 or 929 of the Specification.

7.4.1.12 *Binder* – dense binder course asphalt concrete shall comply with Clause 906 or 929 of the Specification and shall have a minimum thickness of 55mm.

7.4.1.13 *Surfacing* - surface course shall comply with Clause 910, 911 or 942, with a minimum thickness of 35mm. Actual thickness depends on the type of material selected.

7.4.1.14 Construction thickness for different types of road is indicated in Table 7.1. The foundation thickness (combined capping and sub-base layer) is based on an assumed minimum sub-grade CBR of 3% and would need to be revised for CBR values lower or higher than this value. Interim Advice Note, **IAN73**, for foundation design and Volume 7 of the **DMRB HD 26** for asphalt design should be consulted before the final selection of a pavement design for other than a small scheme where the economics are not significant.

7.4.1.15 *Recycled materials* - recycling of existing pavement material is an alternative way to construct roads and use of such materials in carriageway and footway construction will be considered favourably by the Council. The cold recycling of material is now a major construction activity. Cold recycling can contribute to a reduction in energy, fuel and material consumption. Where its use is agreed with the Council, a cold recycling pavement should be designed according to the **TRL Report TRL611**.

7.4.1.16 *Two stage construction* - two stage construction shall be adopted to avoid construction damage to the surface course and the developer should bear this in mind when programming the works. Any settlement that may occur shall be taken up with regulating course before the laying of the next layer(s). Early reinstatement of openings or failed areas is essential. Before the regulating course or surface course is laid, the top of the previous course shall be well cleaned and tack coat (refer to Clause 920) applied at the rate of 0.6 litre per square metre.

7.4.1.17 *Temporary drainage* - consideration should be given to the temporary drainage of the first stage, i.e. base course, to minimise ponding caused by the projection of gully gratings above the temporary surface, either by adjustment of gully frames or another approved method. This applies particularly in large projects where the construction period may be long and the wearing course not laid before a winter work period.

7.4.1.18 *Tie in points* - special attention should be paid to the area where the new construction ties in to the existing road network, as this location is prone to failure due to poor compaction and the ingress of water. Each layer should be stepped back by a minimum of 300mm.

Table 7.1 Carriageway Pavement Construction

| Road Type | Sub-base | Base | Binder Course | Surface Course |
|---|--|-----------------------------------|-------------------------------------|--|
| Strategic Route or Main Distributor | Designed in Accordance with Vol 7 DMRB | | | |
| Local Distributor or Industrial Access Road | 350mm Type 1 to CI 803 | 130mm Dense Base to CI 906 or 929 | 55mm Binder Course to CI 906 or 929 | 45mm Hot Rolled Asphalt to CI 910 or 911 or such other material as approved by the Council (<i>Note 4</i>) |
| Main Residential Street | 350mm Type 1 to CI 803 | 80mm Dense Base to CI 906 or 929 | 55mm Binder Course to CI 906 or 929 | |
| Minor Residential Street or Car Park | 300mm Type 1 to CI 803 | 65mm Dense Base to CI 906 or 929 | 55mm Binder Course to CI 906 or 929 | |
| Home Zone, Courtyard or Cul-de-Sac | Construction to be agreed with the Council | | | |
| Rural Road | Construction to be agreed with the Council | | | |

Notes to Table 7.1:-

1. *Table 7.1 is for guidance only and is based on a 3% CBR, with a combined sub-base and capping layer. The site-specific actual design requirements are to be based on actual CBR test results.*
2. *The first 450mm depth, from the finished road surface, shall be non frost susceptible materials.*
3. *The penetration value of binder and the polished stone value of chippings shall be approved by the Council.*
4. *The Council will consider the use of Stone Mastic Asphalt and proprietary thin surface materials in certain circumstances. However, such materials might not be deemed suitable on a heavily trafficked road; where there are heavy turning movements; on roundabouts or at busy bus stops.*

7.4.1.19 *Rural roads* – in many rural locations, levels of traffic are significantly lower than those experienced in urban situations. As a result, carriageway pavement construction thicknesses can sometimes be relaxed, depending on the scale and type of development. It is recommended, therefore, that early discussions are held with the Council to agree possible construction relaxations from the requirements of Table 7.1.

7.4.1.20 Appropriately designed surface dressing will be an acceptable material for a minor residential road in a rural location, with the rest of the construction make-up to be agreed with the Council.

7.4.1.21 *Concrete Block Paving* – concrete block paving is considered to be acceptable for carriageway pavement construction in the following locations:-

- (a) pedestrian/vehicle shared surfaces, such as Home Zones;
- (b) bus terminals and other locations susceptible to diesel spills; and
- (c) commercial or industrial accesses.

7.4.1.22 Block paving carriageways shall have the same design life as bituminous carriageways, with the block paving (200x100x80 to CI 1107) and bedding layer replacing the binder course and wearing course. Materials and the method of construction shall be in accordance with **BS EN1338: Concrete Paving Blocks** and **BS 7533-3: Code of Practice**. The colours of the paving blocks must be agreed with the Council, in advance of construction.

7.4.1.23 It is very important that block paving carriageways incorporate adequate provision for the drainage of the unbound materials, especially where the road has a low longitudinal gradient. Where the blocks are laid on concrete, cement or bituminous base, appropriate drainage of the bedding layer must be provided.

7.4.1.24 Slip/skid resistance for block paving is described in **BS7533-12**.

7.4.1.25 Where a permeable block paving surface is to be used as part of a sustainable drainage system, the design of the underlying drainage layers shall be compatible with the proprietary system used. Geotextiles shall be employed as considered appropriate. A typical design of drainage layers is given in Table 7-2 with the final design to be agreed with the Council. In some circumstances, the Council may require the provision of a secondary drainage system as back up.

7.4.1.26 If acceptable to the Council, natural blocks may be used and should be in accordance with the **SCOTS Natural Stone Paving Guide**.

Table 7.2 Block Paving carriageways

| Type | Sub-base | Base | Bedding Course | Surface Course |
|---|---|--|---|---|
| Urban Locations | | | | |
| Precast Concrete Blocks | | | | |
| Pedestrian/vehicle shared surfaces (such as Home Zones, car parking) | 320mm Type 1 to CI 803 | None | Min 30mm bed 6:1 sand/cement Or 50mm sand | 200x100x80 to CI 1107 |
| | 270mm Type to CI 803 | Impermeable surface 70mm Dense Base to CI 906 or 929 | 30mm sand | |
| Bus terminals and other locations susceptible to diesel spills or commercial or industrial accesses | 300mm Type 1 to CI 803 | 150mm Concrete C32/40 | Min 30mm bed 6:1 sand/cement | 200x100x80 to CI 1107 |
| Permeable Block Paving | | | | |
| Pedestrian/vehicle shared surfaces (such as Home Zones, car parking) | 200mm lower base – (20/40) BS EN 13242 recommended grading tolerance Gc 80/20. GTnr, f4 | 200mm upper base – (10/20) BS EN 13242 recommended grading tolerance Gc 80/20. GTc 20/15 | Laying course – (2/6.3) BS EN 13242 recommended grading tolerance Gc 80/20. GTc 20/15 | 200x100x80 permeable block pavior to BS EN 1338 |

7.4.2 **Footways, Footpaths and Cycle Tracks**

7.4.2.1 Footway, footpath and cycle track pavement construction shall be in accordance with Table 7.3, unless an alternative design is agreed with the Council.

7.4.2.2 Where an existing footway/footpath is to be extended, say, into a new residential development, there may be environmental reasons and advantages for constructing the new section with materials that match the existing ones and this should be discussed with the Council.

7.4.2.3 Cycle tracks and shared pedestrian/cycle facilities should only have flexible construction, unless agreed otherwise with the Council.

Table 7-3 Footway/Footpath/Cycle Track Construction

| Type | Sub-base | Binder Course | Surface Course ¹ |
|--|---|---|--|
| Urban Locations | | | |
| Flexible Construction | 100mm ² Type 1 to CI 803 | 40mm binder course to CI 906 or 929 or | 30mm Hot Rolled Asphalt to CI 910 or 25mm close graded asphalt concrete Surface Course to CI 912 or |
| | | Single course 60mm close graded asphalt concrete Surface Course to CI 912 | |
| Small Element Slabs (<i>Not suitable for cyclists</i>) | 150mm Type 1 to CI 803 | 25mm bed medium course sand | 400x400x60mm to CI 1104S |
| Block Paving Construction (<i>Pedestrian areas only</i>) | 150mm Type 1 to CI 803 | min 50mm sharp sand | 200x100x65mm thick Rectangular Block Paving to CI 1107 |
| Other | Other types, such as granolithic concrete, setts and natural stone slabs, are only suitable where specified by planning requirements, with construction make-up to be agreed. | | |
| Rural Locations | | | |
| Flexible Construction for footways, footpaths and cycle tracks | 200mm Type 1 to CI 803 or suitable recycled material | 40mm Dense binder course to CI 906 or 929 or | 25mm Hot Rolled Asphalt to CI 910 or 25mm close graded asphalt concrete Surface Course to CI 912 or |
| | | Single course 50mm close graded asphalt concrete Surface Course to CI 912 | |

Notes to Table 7.3:-

1. *Where Hot Rolled Asphalt is used as the surface course, prior to rolling 6mm or 10mm limestone or other approved chippings shall be applied at an approximate rate of 1kg per square metre.*
2. *The sub-base shall be increased to 150mm if the Council considers locations may be liable to overrun by vehicles.*
3. *The first 450mm depth, from the finished surface, shall be non frost susceptible materials and this may require the depth of sub-base material to be increased, unless agreed otherwise with the Council.*

7.4.3 Vehicular Footway Crossings

7.4.3.1 For lightly trafficked small developments, it may be acceptable for vehicles to traverse the footway/footpath, as long as the pavement construction of the crossing point is strengthened. Vehicular footway crossings can have either flexible or rigid construction, in accordance with Table 7.4, but should match the adjacent footway/footpath type. Precast concrete slab construction will not be permitted for such crossings.

Table 7.4 Vehicular Footway Crossing Construction

| Type | Sub-base | Binder Course | Surface Course |
|---|--|--|--|
| Residential Driveway Flexible Construction | 200mm Type 1 to CI 803 | 50mm binder course to CI 906 or 929 Or | 30mm Hot Rolled Asphalt to CI 910 or 25mm close graded asphalt concrete Surface Course to CI 912 or |
| | | Single course 60mm asphalt concrete surface course to CI 912 | |
| Residential Driveway Rigid Construction to match existing footway | Construction to be approved by the Council | | |
| Commercial Access Flexible Construction | 350mm Type 1 to CI 803 | 60mm binder course to CI 906 | 40mm Hot Rolled Asphalt to CI 910 or CI 911 or 35mm asphalt concrete close graded Surface Course to CI 912 |
| Commercial Access Rigid Construction | 210mm Type 1 to CI 803 | 200mm 30/20 Concrete to CI 1704 | 40mm Granolithic Concrete To CI 1106A |

Notes to Table 7.4:-

1. Where Hot Rolled Asphalt is used as the surface course, prior to rolling 6mm or 10mm limestone or other approved chippings shall be applied at an approximate rate of 1kg per square metre.
2. The first 450mm depth, from the finished surface, shall be non frost susceptible materials and this may require the depth of sub-base material to be increased unless agreed otherwise with the Council.

7.4.3.2 Emergency access – where a footway/footpath/cycle track is also intended to act as an emergency access route, then it needs to be designed to accommodate commercial vehicles and constructed to commercial access standards, as set out in Table 7.4.

7.5 Kerbing and Edging / Oirean Chabhsairean

- 7.5.1 All carriageways, footways, footpaths and cycle tracks shall be provided with a kerb or edging, as detailed in Figures 7.1 and 7.2, unless agreed otherwise with the Council. Usually, the kerb shall be precast concrete or plastic but where, for reasons of conformity with existing development or as a planning requirement, kerbs of a different material are required, this shall be agreed with the Council.
- 7.5.2 *Kerbs* – Kerbs shall conform to **BS EN 1340 Concrete Kerb Units** and may be manufactured from precast concrete, although the Council does encourage the use of recycled material as an alternative. Recycled plastic kerbs have health and safety advantages, reducing the need for mechanical handling which is a requirement for precast concrete kerbs.
- 7.5.3 Kerbs shall be set on a 25mm thick Class 1 mortar bed, sitting on a Class ST2 concrete foundation, with foundation dimensions as shown in Figures 7.1 and 7.2 and dependent on road type. Kerbs shall also be haunched with Class ST1 or ST2 concrete.
- 7.5.4 On conventionally constructed roads, kerbs shall be set with an upstand of 125mm, unless approved otherwise with the Council, except at pedestrian and vehicular crossing points, where the upstand shall be reduced to a maximum of 6mm (ideally flush) and 20mm, respectively.
- 7.5.5 On shared surfaces, where kerbs are laid and pedestrians are able to generally walk on either side of the kerb, its upstand should be a maximum of 6mm.
- 7.5.6 Where the development road joins an existing road, agreement must be obtained from the Council to determine the type of transition kerb to be used, together with the extent of any existing kerbing that may need to be replaced.
- 7.5.7 Special kerbs – At bus-stops, high upstand bus access kerbs shall be provided in accordance with the guidelines given in **Disability Discrimination Act - Good Practice Guide For Roads**.
- 7.5.8 *Edging* – edging for footpaths and cycle tracks shall be flush with the walking/running surface. In remote areas and with the approval of the Council, footpaths and cycle tracks may be constructed without edging kerbs, as long as the sub-base is laid 500mm wider than the surfacing layers on both sides.
- 7.5.9 *Service strips* - where a shared surface has a service strip, edging kerb should be laid at the rear of the service strip, to highlight the limits of the prospectively adoptable road, unless some other form of delineation is agreed.

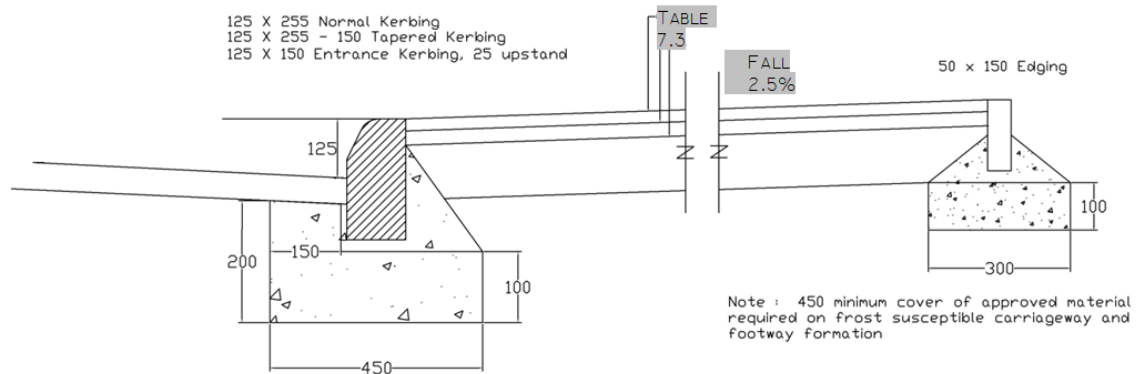

Figure 7.1 Kerbing for Access Roads and Bus Routes

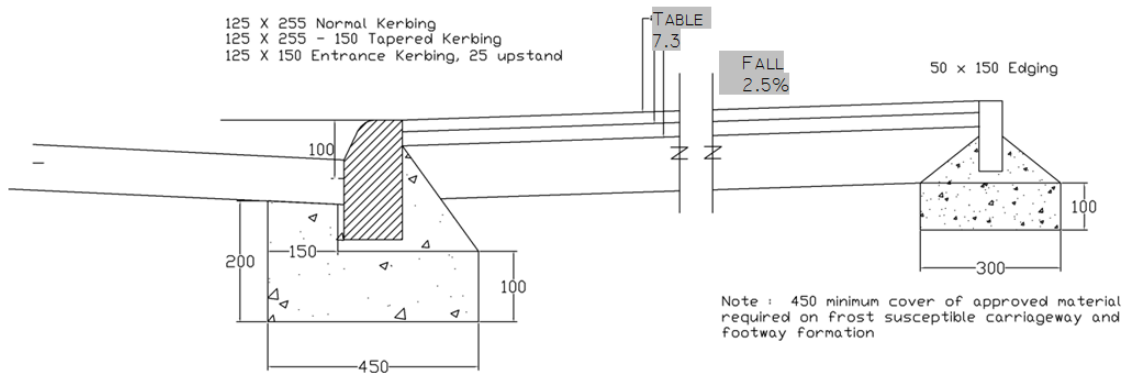

Figure 7.2 Kerbing for Residential Areas and Car Parks

7.6 Landscaping and Verges / Dealbhadh-tìre agus Fàil Rathaid

7.6.1 Landscaping has an important role in creating attractive places, including streets, and planting, especially trees, helps to soften the street scene whilst also generating visual interest, improving the local microclimate and providing valuable habitats for wildlife. However, landscaping proposals within the prospectively adoptable road boundaries or on adjacent land that might impact on visibility splays must be discussed with the Council at an early stage, to agree verge widths, planting type and limitations.

7.6.2 *Appropriate planting* - whilst planting is to be encouraged, its design needs careful consideration, in order to ensure that (a) appropriate plants are used and (b) future maintenance requirements are minimised, especially in those areas that will subsequently be adopted by the Council. Plants can include trees, shrubs, flowers, ground cover, climbers, bulbs and grass and, in general, the planting of native species will be encouraged in rural areas but can be more relaxed in urban areas.

- 7.6.3 *Trees* – trees should be sited to permit full branch growth and spread. Trees that are too close to the kerb may come into regular contact with high vehicles, affecting their growth. Where this could happen, trees should be sited such that their branches will not be within 450mm of the kerblines for their first 5.3m height.
- 7.6.4 Trees and shrubs should not be sited where they could cause damage to adjacent footways, buildings or services, unless their roots are contained. Whilst the best conditions for planting trees are in free draining, unconstrained tree pits, this is not always possible, especially within the urban environment. Where tree roots need to be contained, a tree pit of minimum volume of 3m³ should be provided and prepared to allow adequate drainage. In urban locations, trees may require guards to protect them from vandalism or impact damage.
- 7.6.5 *Soft verges* – soft verges shall be grassed, unless agreed otherwise with the Council, in consultation with Statutory Undertakers, where appropriate. A permanent demarcation must be provided to highlight the boundary between the rear of the verge and adjacent private property (usually in the form of fencing or wall or of edge kerbing, which can be provided as single kerbs at 3m centres along the boundary).
- 7.6.6 *Topsoil* – topsoil is to be spread to a uniform thickness of 150mm on all areas to be seeded and/or planted unless agreed otherwise by the Council. Prior to placing the topsoil, the top 200mm of underlying ground shall be broken up to facilitate free drainage, with all stones exceeding 100mm in size, together with any building waste, removed.
- 7.6.7 *Grass seed* – grass seed shall be sown during appropriate times of the year. The developer shall be responsible for resowing, in the following season, those areas where the initial seeding was not successful. The grass seed mixture for urban locations shall be agreed with the Council, prior to sowing. For rural locations, the following mixture shall be acceptable:-

| | Rate of Spread 12g/m ² |
|--|-----------------------------------|
| <i>Sheep fescue Bonito "Fescue Ovina"</i> | 30% |
| <i>Red fescue Dawson "Festuca rubra subsp rubra"</i> | 45% |
| <i>Brown top Highland "Agrostis castellana"</i> | 25% |

although the Council may agree other mixtures, where deemed appropriate.

- 7.6.8 *Planting maintenance* – regular maintenance of newly planted trees and shrubs is essential during their first three years, in order to ensure that they grow and flourish properly. The developer will be required to prepare a maintenance schedule to cover this period and include regular inspections, weed control and replacement planting of failing trees or shrubs. Unless the landscaping is located with prospectively adoptable areas, it will remain private and the developer will be required to arrange on-going maintenance, which shall be to the satisfaction of the Council.

7.6.9 *Hard verges* – the form of any hard landscaping must be agreed with the Council during early stages in the design process and it must also take account of any planning requirements. Where hard verges are provided on Distributor Roads, there may be a requirement to surface all or part of the hard verge with pedestrian deterrent paving.

7.6.10 *Home Zones* – the design of Home Zones recommends the use of planting to create attractive streets and also act as traffic calming features. In such circumstances, the planting should be semi-mature when provided, to ensure these objectives are achieved from opening of the development.

SECTION 3 FLOODING AND CONSTRUCTION TRAFFIC
EARRANN 3 – TUILTEAN AGUS TRAFÁIG TOGAIL

Section 3 of the Roads and Transport Guidelines for New Developments document provides information with regard to flooding issues, as they can have a significant impact on new development. The section also provides information and guidance with regard to the impact of construction traffic.

Section 3 includes the following:-

Chapter 8 – Flooding

Chapter 9 –Construction Traffic

CHAPTER 8 – FLOODING / CAIBIDEAL 8 – TUILTEAN

8.1 General / Coitcheann

- 8.1.1 With its extensive coastline, steep topography and high rainfall, land within the Scottish Highlands can be at high risk of flooding from many sources. All land can be subject to flooding to some degree or influence flooding elsewhere and the consequences of flooding can be devastating on people, infrastructures and the natural environment.
- 8.1.2 In placing new developments or upgrading existing infrastructures, it is important to assess the risk of flooding from all sources and its consequences now and in the future. The level of flood risk should be appropriate for the development and it should not increase flood risk elsewhere. Recognising that climate change affects the environment and needs to be considered, flood risk should be assessed for current and future conditions.
- 8.1.3 The management of flood risk must be considered from the inception phase of a project in order to inform and best shape the development to any particular site constraints. Early consultation with the Council and Scottish Environment Protection Agency (SEPA) officers is therefore essential.
- 8.1.4 As a general rule, all new developments must not result in the increase in flood risk to any other property regardless of how trivial this increase may appear to be. All new structures must not be prone to flood damage from any source for events up to and including a 0.5% Annual Exceedance Probability (AEP) (also referred to as a 1 in 200 year event).

8.2 Legislation / Reachdas

8.2.1 *Flood Risk Management (Scotland) Act*

8.2.1.1 The **Flood Prevention (Scotland) Act 1961** and **Flood Prevention and Land Drainage (Scotland) Act 1997** Acts were superseded by the **Flood Risk Management (Scotland) Act 2009**, which received Royal Assent in June 2009. The new Act has updated legislation to streamline the development of flood protection schemes and introduce a more sustainable and modern approach to flood risk management. The Act has also transposed the **European Floods Directive** into Scottish law. Under the Act local authorities will be responsible for preparing local flood management plans while SEPA will be responsible for preparing wider district plans.

8.2.1.2 Specific measures within the **Flood Risk Management (Scotland) Act** include:-

- A framework for coordination and cooperation between all organisations involved in flood risk management;
- Assessment of flood risk and preparation of flood risk management plans;
- New responsibilities under SEPA, Scottish Water and Local Authority functions for flood risk management;
- A revised, streamlined process for flood risk management measures include deemed planning permission for all confirmed flood protection schemes. However, the schemes will still require to secure authorisation through **The Water Environment (Controlled Activities) (Scotland) Regulations 2005**;
- New methods to enable stakeholders and the public to contribute to managing flood risk; and
- A single enforcement agency, SEPA, for the safe operation of Scotland's reservoirs.

8.2.1.3 Under the Act, Local Authorities have general power to manage flood risk, including operations related to a flood protection scheme and any other flood protection work if considered necessary to reduce flood risk. They have also a duty to carry out clearance and repair works as part of the measures included in a local flood risk management plan.

8.2.1.4 Scottish Water has responsibility for the public drainage system, including both foul and storm water systems. It should be noted that Scottish Water is not obliged to adopt new road drainage in adopted roads or accept road drainage into its system. If Scottish Water does adopt such drainage, this will normally be subject to a Section 7 Agreement, in terms of the **Sewerage (Scotland) Act 1968**.

8.2.1.5 Flooding means flooding from all sources including coastal, rivers, groundwater and surface water.

8.2.1.6 Secondary legislation and technical guidance are expected to be published in the near future. Up to date information should therefore be sought from the Scottish Government website <http://www.scotland.gov.uk/Topics/Environment/Water/Flooding> or SEPA website <http://www.sepa.org.uk/flooding.aspx>

8.2.2 **Planning**

8.2.2.1 **Scottish Planning Policy** (Flooding and Drainage) - **SPP** includes the Scottish Government's current policy and guidance on flooding in relation to new development. The following points cover core aspects of the guidance for new developments in flood risk areas:-

- Little or no risk area (less than 0.1% AEP (1:1000)) – no general constraints;
- Low to medium risk area (0.1% to 0.5% AEP (1:1000 – 1:200)) – suitable for most development but not essential civil infrastructure; and

- Medium to high risk area (0.5% AEP (1:200)) or greater – in built up areas with flood prevention measures, most brown-field development should be acceptable except for essential civil infrastructure; undeveloped and sparsely developed areas are generally not suited for most development.

8.2.2.2 **Planning Advisory Note 61: Planning and Sustainable Drainage Systems** and **Planning Advisory Note 69: Planning and Building Standards Advice on Flooding** provide guidance on the implementation of SUDS and planning system in relation to the management of flood risk.

8.2.3 **Controlled Activities (Scotland) Regulations 2005**

8.2.3.1 **The Water Environment and Water Services (Scotland) Act 2003** was introduced in order for Scotland to meet the requirements of the European **Water Framework Directive** which requires all inland and coastal waters to reach “good status” by 2015. **The Water Environment (Controlled Activities) (Scotland) Regulations 2005 (CAR)** is the mechanism which has been implemented to prevent a degrading in water quality and the adoption of best practice for all works impacting on the water environment.

8.2.4 **Coast Protection Act 1949**

8.2.4.1 Under the **Coast Protection Act 1949**, the Council is the Coast Protection Authority for its own local government area. The Act stipulates that:-

- Local authorities may carry out Coast Protection works which may be new or maintenance works; and
- Local authorities must consider proposals for Coast Protection works or for other works on the coast, to be carried out by others.

8.2.4.2 The Council has produced supplementary guidance, “**Flood Risk and Drainage Impact Assessment**” and developers should make reference to this document.

8.3 **Management of flood risk for new developments and infrastructures / Rianachd cunnart thuiltean airson leasachaidhean agus bun-structair ùr**

8.3.1 **Introduction**

8.3.1.1 Before considering the development of a site and commencing a design, a developer needs to be aware of any potential flooding issue that could affect the site. This includes the site being prone to existing flooding or the development exacerbating flooding at a location remote from the site. In this assessment the developer will need to take account of the current policy on new development and flood risk, currently **SPP**. This policy may prohibit certain developments on particular sites.

8.3.1.2 It is the developer's responsibility to demonstrate that the site is either not subject to flooding and erosion or to incorporate such measures that deal with them. This requirement also applies to any prospectively adoptable public road. The developer is also responsible for ensuring that any measure does not cause detriment to any other party.

8.3.2 **Initial Flood Risk Assessment**

8.3.2.1 Flooding can affect any type of development, including a single house. It is important, therefore, that a developer undertakes some form of flood assessment at the project inception stage. Such an assessment can be very brief if the risk is considered to be minimal. For all developments, particularly critical infrastructure, consideration shall be given to how the site can be safely accessed or exited during an extreme flood event.

8.3.2.2 An initial flood risk assessment will generally include a record of a site walkover survey, consultation with council staff and SEPA and the collation and review of any publicly available information regarding nearby historical flooding. The initial assessment should also include a description of the proposed development. It should be undertaken by an experienced person and seek to assess if there are any potential sources of flooding on or close to the site. All sources of flooding (coastal, fluvial, pluvial and groundwater) should be considered as appropriate.

8.3.2.3 For sites close to the coast, there are no set rules for when coastal flooding could affect a development; however generally developments more than 5 metres above the mean high water spring level will be considered safe from coastal flooding.

8.3.2.4 The **Indicative River & Coastal Flood Maps** available through the SEPA website (www.sepa.org.uk) may be beneficial during this initial assessment.

8.3.2.5 Evidence of erosion, either on the site or nearby, which could impact on development, should also be recorded.

8.3.2.6 The developer can also seek advice from the Council, as its staff may have local knowledge of flooding. In addition, SEPA provides information on areas that are deemed to be at risk of flooding, but which tends to be of a general nature rather than showing specific local problems.

8.3.3 **Detailed Flood Risk Assessment**

8.3.3.1 If the initial flood risk assessment suggests that the site may be prone to flooding or if the Council considers that the development proposals may introduce or exacerbate flooding elsewhere, then the developer could be requested to provide a full Flood Risk Study, which shall be prepared by a qualified hydrologist or similar competent person. It should be prepared in compliance with the latest SEPA guidance on the preparation of such documents and should consider flooding from all potential sources as appropriate. The final proposed development should be in compliance with all the relevant legislation and design guidance.

8.3.3.2 The current flood protection standards within **SPP** have been selected so as to provide some resilience to more severe flood events which can be expected as a result of climate change. Hence, there is no specific requirement to include a further allowance for climate change within proposed designs, although such an approach is recommended. In all cases, a sensitivity study should be undertaken to demonstrate that the impact of climate change on the development is tolerable.

8.3.3.3 It should also be noted that the flood protection standards within **SPP** make no allowance for freeboard, hence freeboard to account for both uncertainty and physical processes should be included for all developments based on current best practice. A minimum freeboard of 500mm is recommended in accordance with SEPA guidance, but each site should be considered according to its own conditions and a lower or higher freeboard may be justifiable.

8.3.3.4 If a site is envisaged to be susceptible to flooding, especially a severe flood event, then the developer must consider any likely flood routing and provide details of how any impact can be mitigated against. For example, how can flood water from a 1 in 200 year event get to proposed attenuation areas and would this be via the road network? Culs-de-sac that are accessed downhill should be avoided unless an escape flow route for flood water is incorporated.

8.3.4 **Drainage**

8.3.4.1 Drainage of a development should allow for a drainage system that accommodates a 3.3% AEP (1 in 30 year) rainfall event, as standard. The drainage system should also be assessed for the safe passage of design exceedance events, 0.5% AEP (1 in 200 year) flood for normal development or 0.1% AEP (1 in 1000 year) for critical infrastructure and must demonstrate no intolerable consequences in the event of the drainage system failure or exceedance.

8.3.4.2 The Council shall be consulted to determine appropriate SUDS design standards and features for the proposed development. It should be noted that Scottish Water is under no obligation to adopt road drainage or to accept water from road drainage systems. If Scottish Water does agree, a Section 7 Agreement may be required. Section 5.25 sets out road drainage requirements.

8.3.4.3 Where the development proposes a culvert, inlet and outlet screens should be provided where deemed necessary, in agreement with the Council. Future maintenance requirements must be established and approved by the Council, in order to reduce flooding events due to a build-up of debris.

8.3.5 **Water Environment**

8.3.5.1 A **CAR** licence is required for all activities within the water environment. The licensing system which is managed by SEPA divides works into four areas:-

- abstraction;
- pollution control (discharge);

- impoundment; and
- engineering,

with a range of licensing levels depending on the level of risk. It is essential to consider the requirements for obtaining an appropriate licence for the proposed works and this should be discussed with SEPA at the earliest opportunity. The **Water Environment (Controlled Activities) (Scotland) Regulations 2005 - a Practical Guide**, available from SEPA web site, provides details of which activities are regulated and the conditions of each authorisation.

8.4 General Design Requirements / **Riathanasan Dealbhaidh Coitcheann**

8.4.1 The following technical documents are recommended sources of additional relevant information:-

The Culvert Design Manual R168 (CIRIA, 1997)

Designing for exceedance in urban drainage – good practice C635 (CIRIA, 2006)

The Rock Manual C683 (CIRIA, 2007)

The SUDS Manual C697 (CIRIA, 2007)

Fluvial Freeboard Guidance Note (Environment Agency, 2000)

Design Manual for Roads and Bridges Volume 4 Section 2: Drainage (DMRB 4.2) (Highways Agency, 2006)

Design Manual for Roads and Bridges Volume 3 Section 4: Assessment of scour at highway bridges (DMRB 3.4) (Highways Agency, 2006)

The Flood Estimation Handbook (Institute of Hydrology, 1999)

Sewers for Scotland - 2nd Edition (Scottish Water, 2008)

SUDS for Roads (SUDS Working Group, 2009)

CHAPTER 9 – CONSTRUCTION TRAFFIC / CAIBIDEAL 9 – TRAFÀIG TOGAIL

9.1 Introduction / Ro-ràdh

9.1.1 For some developments, impacts arising from construction traffic can be significant. By their nature, they are intrusive, creating potential environmental problems that relate to traffic movements, noise, dust, vibration and road damage. Construction traffic, especially abnormal loads, may require to travel along existing narrow roads, especially within rural areas, affecting both the road network and local communities. **As a result, construction traffic issues that are a concern to the Council need to be considered during the planning stage.**

9.2 Abnormal Loads / Eallaichean Neo-àbhaisteach

9.2.1 The construction of some types of new development can sometimes require the delivery of abnormal loads to the construction site and these can have a significant impact on the surrounding road network.

9.2.2 Abnormal loads, by their very nature, can vary in size and weight. As delivery can involve travel along different types of road, often resulting in delay to general traffic, together with the need for occasional closure of roads, it is clear that the movement of abnormal loads can often be a complex operation that needs to be carefully planned.

9.2.3 Where an abnormal load will use roads within the Highland Council area, early discussions must be held with the Council and the Trunk Roads Authority. There may also be a requirement to co-ordinate local delivery times, in order to minimise impact on road users. For example, avoiding peak traffic times, school activities or other traffic-generating events would need to be taken into account and discussed with the Council.

9.2.4 Abnormal loads are often long and wide, resulting in the need for large turning circles. It is essential, therefore, that the developer undertakes a Swept Path Analysis (horizontal and vertical) of the abnormal loads route. This could highlight the need for various local road improvements that could be temporary or permanent changes. Further guidance is set out in Appendix 9.

9.2.5 The full extent of any improvements would need to be agreed with the Council and should also be highlighted within an associated Environmental Impact Assessment for the development. Whilst some measures could be permanent, the majority are likely to be temporary (which could include road re-alignment that subsequently needs to be re-instated). The developer would normally be required to fund these improvements and any subsequent reinstatements. In some circumstances, there may be a requirement to prepare a Traffic Management Plan where a high number of vehicle movements are envisaged.

9.2.6 With regard to carriageway widening, in certain circumstances there may be a requirement to acquire land to allow the widening to be implemented and this may result in land ownership issues having to be negotiated and resolved by the developer. In addition, some of the

improvement works may require separate planning approval or even listed building consent if the works impact on a listed building. Some affected trees may be covered by Tree Preservation Orders and would need an application and approval from the Council.

9.2.7 If delivery of abnormal loads requires a developer to undertake improvements (either temporary or permanent) to some of the roads, the Council is likely to require the developer to enter into a legal agreement, usually in terms of Section 48 of the **Roads (Scotland) Act 1984** or any other suitable legal agreement as approved by the Council.

9.2.8 Further advice and information on abnormal loads is given in Appendix 9.

9.3 Renewable Energy Developments / Leasachaidhean Lùth Ath-nuadhachail

9.3.1 Onshore Wind Farms

9.3.1.1 For wind farm proposals, a developer should be aware that the Council will require a Transportation Assessment (TA) to be submitted that must consider the existing road network, transportation constraints and potentially sensitive routes or communities. Abnormal load routes are to be part of the TA, which may require structural assessments.

9.3.1.2 For the majority of future wind farm schemes, abnormal loads will be common requirements. Blades can be up to 45m long or more and some of the turbine components are extremely heavy, weighing over 200 tonnes. As mentioned in Section 9.2, there is a need to ensure that appropriate routes for transferring these abnormal loads are agreed and enforced, especially as the final approach to many sites is by narrow minor roads.

9.3.1.3 A wind farm vehicular site access must provide appropriate visibility splays and suitable surface water drainage. Within the site, the wind turbines are likely to be located some distance from the nearest public road, requiring internal access tracks to be constructed. As the access tracks need to accommodate abnormal loads, they have to be of a suitable width. These tracks are normally constructed from hard-core material and the developer will usually be encouraged/allowed to use material obtained from borrow pits within the site area, to reduce construction traffic. On-site concrete batching should also be considered, as this can also result in a reduction of associated vehicles on the local road network.

9.3.1.4 A suitable turning area must be constructed within the site, to accommodate abnormal load delivery vehicles, construction vehicles and future maintenance vehicles. During the construction period, a wheel-wash system shall be provided.

9.3.2 Other Types of Renewable Energy Developments

9.3.2.1 Where other types of renewable energy schemes, such as offshore wind farms, wave/tidal power, hydro-electric and bio-fuel developments, require consent or approval from the Council, these will be considered on a site-by-site basis as some developments may generate site-specific issues,

including abnormal loads and significant volumes of construction traffic. Associated developments, such as transmission projects, can also result in significant transport impacts and the Council would usually require an associated TA to be provided.

9.3.2.2 There are some types of renewable energy schemes, be they new development or significant maintenance works, which do not require planning consent from the Council. However, if these works are likely to result in significant levels of construction traffic or the need for abnormal loads then the proposals must still be discussed with the Council, in its role as Local Roads Authority. This will ensure that any detrimental impact on the surrounding road network or affected local communities is minimised.

9.3.3 **General Disturbance**

9.3.3.1 *Peat* - some onshore renewable energy schemes may be sited in areas where peat is present. Disturbance of peat can release carbon into the atmosphere, thereby potentially contributing to greenhouse gas emissions. As a result, developments should be designed to minimise soil disturbance, particularly in relation to roads, access tracks, turbine bases and other infrastructure. Planning applications will require geotechnical and hydrological information, including risk of landslide.

9.3.3.2 *Construction* - **Planning Advice Note 45 – Renewable Energy Technologies (PAN45)** also highlights the issue of potential construction disturbance. Given the rural location of many renewable energy schemes, they are often served by minor roads that need to accommodate the movement of large components and it is important, therefore, that heavy vehicles are controlled. This can apply to the on-going operation and maintenance of the site facilities. **PAN45** also notes that substantial site access tracks are often constructed and if these are no longer required then it is recommended that consideration be given to their removal.

9.4 **“Wear and Tear” Agreements / *Aontaidhean a thaobh Caitheamh Àbhaisteach***

9.4.1 Even with road improvements, whether temporary or permanent, development construction traffic and the movement of associated abnormal loads can lead to potential damage to existing public roads. In such an event, a Local Roads Authority has the powers, under the terms of Section 96 of the **Roads (Scotland) Act 1984**, to seek extraordinary expenses incurred in maintaining roads damaged by heavy vehicles or traffic. As a result, planning consent for a new development that is likely to generate significant volumes of construction traffic and/or abnormal loads, such as wind farms or very large developments, will usually require the developer to enter into a “Wear and Tear” Agreement with the Council to cover costs of any damage caused by the development to the local road network.

9.4.2 As part of the “Wear and Tear” Agreement, the developer will be required to undertake a Road Assessment Condition Survey of existing road conditions of agreed delivery routes, from point of origin to the site. Usually, the survey shall be undertaken jointly with the Council, in order to agree the survey results. The Council would then monitor conditions until construction work was

completed at which time a Final Road Condition Survey would be undertaken to identify any necessary reinstatement work that can be reasonably attributed to the new development.

APPENDICES / EÀRR-RÀDHAN

| | |
|-----------------------------|---|
| Appendix 1 Eàrr-ràdh 1 | Road and Community Works Area Offices Oifisean Sgìreil Rathaidean agus Obraichean Coimhearsnachd |
| Appendix 2 Eàrr-ràdh 2 | Planning and Building Standards Offices Oifisean Inbhean Dealbhaidh agus Togail |
| Appendix 3 Eàrr-ràdh 3 | TA1 Form Foirm TA1 |
| Appendix 4 Eàrr-ràdh 4 | Travel Plan Guidance Stiùireadh Plana Còmhdhalach |
| Appendix 5 Eàrr-ràdh 5 | RCC Forms Foirmean-iarrtais Gèilleadh Togail Rathaid |
| Appendix 6 Eàrr-ràdh 6 | RCC Construction Compliance Statement Aithris-gèillidh Aonta Togail Rathaid |
| Appendix 7 Eàrr-ràdh 7 | Public Transport Bus Stop Specification Sònrachadh Stad Bus Còmhdhail Phoblaich |
| Appendix 8 Eàrr-ràdh 8 | Refuse and Recycling Collection Requirements Riathanasan Togail Sgudail is Ath-chuairteachaidh |
| Appendix 9 Eàrr-ràdh 9 | Abnormal Loads Eallaichean Neo-àbhaisteach |
| Appendix 10 Eàrr-ràdh 10 | Access to Single Houses and Small Developments Booklet Leabhran mu Shlighean-inntrigidh gu Taighean Singilte agus Leasachaidhean Beaga |
| Appendix 11 Eàrr-ràdh 11 | Access for Forestry Extraction Slighe airson Às-tharraing Coilltearachd |
| Appendix 12 Eàrr-ràdh 12 | Parking Places for Disabled Persons Àiteachan Parcaidh do Dhaoine Ciorramach |

ROADS AND TRANSPORT GUIDELINES FOR NEW DEVELOPMENTS
STIÙIRIDHEAN RATHAIDEAN IS CÒMHDHAIL AIRSON LEASACHAIDHEAN ÙRA

APPENDIX 1
EÀRR-RÀDH 1

ROADS AND COMMUNITY WORKS AREA OFFICES
OIFISEAN SGÌREIL RATHAIDEAN AGUS OBRAICHEAN COIMHEARSNACHD

CAITHNESS, SUTHERLAND AND EASTER ROSS

| | |
|--|---|
| <p>Drummuie Golspie KW10 6TA</p> <p>Tel: 01408 635300 Fax: 01408 634041</p> <p>Email: sutherland.tecsadmin@highland.gov.uk</p> | <p>Council Offices Market Square Wick KW1 4AB</p> <p>Tel: 01955 607761 Fax: 01955 604086</p> <p>Email: caithness.tecsadmin@highland.gov.uk</p> |
|--|---|

INVERNESS, NAIRN, BADENOCH AND STRATHSPEY

| | |
|---|--|
| <p>94 Diriebught Road Inverness IV2 3QN</p> <p>Tel: 01463 703111 Fax: 01463 703112</p> <p>Email: Inverness.tecsadmin@highland.gov.uk</p> | <p>Unit 4C Dalfaber Industrial Estate Aviemore PH22 1ST</p> <p>Tel: 01479 812 980 Fax:</p> <p>Email: Badenoch&Strathspey.tecsadmin@highland.gov.uk</p> <p>Council Offices Nairn Address as per Aviemore</p> |
|---|--|

ROSS, SKYE AND LOCHABER

| | |
|---|--|
| <p>Carr's Corner Depot Lochybridge, Fort William, PH33 6XY</p> <p>Tel: 01397 709000 Fax: 01397 705735</p> <p>Email: Lochaber.TecsAdmin@highland.gov.uk</p> | <p>Council Offices High Street Dingwall IV15 9QN</p> <p>Tel: 01349 868440 Fax: 01349 862190</p> <p>Email: Skye&Lochalsh.TecsAdmin@highland.gov.uk</p> |
| <p>Council Offices Dunvegan Road Portree IV51 9HF</p> <p>Tel: 01478 612727 Fax: 01478 612255</p> <p>Email: RossandCromarty.TecsAdmin@highland.gov.uk</p> | |

ROADS AND TRANSPORT GUIDELINES FOR NEW DEVELOPMENTS
STIUIRIDHEAN RATHAIDEAN IS CÒMHDHAIL AIRSON LEASACHAIDHEAN ÙRA

APPENDIX 2
EÀRR-RÀDH 2

PLANNING AND BUILDING STANDARDS OFFICES
OIFISEAN INBHEAN DEALBHAIÐH AGUS TOGAIL

HEADQUARTERS

Council Offices
Glenurquhart Road
Inverness
IV3 5NX

Tel: (01463) 702 250
Fax: (01463) 702 298

Email: planning@highland.gov.uk

CAITHNESS, SUTHERLAND AND EASTER ROSS

Market Square
Wick
KW1 4AB

Tel: (01955) 607 751
Fax: (01955) 606 924
Email:

planning.caithness@highland.gov.uk

Drummuie
Golspie
KW10 6TA

Tel: (01408) 635 352
Fax: 01408 634041

Email:
planning.sutherland@highland.gov.uk

Council Offices
84 High Street
Dingwall
IV15 9QN

Tel: (01349) 868 600
Fax: (01349) 864 675

Email: planning.rossandcromarty2@highland.gov.uk

INVERNESS, NAIRN, BADENOCH AND STRATHSPEY

2nd Floor, Kintail House
Beechwood Business Park
Inverness, IV2 3BW

Tel: (01463) 255200
Fax:
Email:

planning.inverness@highland.gov.uk

100 High Street
Kingussie
PH21 1HY

Tel: (01540) 661 700
Fax: (01540) 661 001
Email:

planning.badenoch@highland.gov.uk

ROSS, SKYE AND LOCHABER

Council Offices
84 High Street
Dingwall
IV15 9QN

Tel: (01349) 868 600
Fax: (01349) 864 675

Email:
planning.rossandcromarty2@highland.gov.uk

King's House
The Green
Portree
IV51 9BS

Tel: (01478) 612 412
Fax: (01478) 613 518

Email: skye.planning@highland.gov.uk

Fulton House
Fort William
PH33 6XY

Tel: (01397) 707 015
Fax: (01397) 707 022
Email: planning.lochaber@highland.gov.uk

ROADS AND TRANSPORT GUIDELINES FOR NEW DEVELOPMENTS
STIÙIRIDHEAN RATHAIDEAN IS CÒMHDHAIL AIRSON LEASACHAIDHEAN ÙRA

APPENDIX 3
EÀRR-RÀDH 3

TA1 TRANSPORT ASSESSMENT FORM
FOIRM TA1 MEASADH CÒMHDHALACH

TA1 TRANSPORT ASSESSMENT FORM

TO BE COMPLETED BY THE APPLICANT FOR ALL PLANNING APPLICATIONS

(Note: this form is not required when the information requested is already provided within a Transport Assessment or for the smallest applications e.g. single house applications)

1. Applicant

2. Location

3. Proposed Development

4. Indicate if the proposed development exceeds the following thresholds:-

| USE | | YES |
|-----------------------------------|--|-----|
| Food retail | >1,000m ² Gross Floor Area | |
| Non-food retail | >1,000m ² Gross Floor Area | |
| Cinemas and conference facilities | >1,000m ² Gross Floor Area | |
| Leisure facilities | >1,000m ² Gross Floor Area | |
| Business | >2,500m ² Gross Floor Area | |
| Industry | >5,000m ² Gross Floor Area | |
| Distribution and warehousing | >10,000m ² Gross Floor Area | |
| Hospitals and Health Facilities | >1,000m ² Gross Floor Area | |
| Higher and further education | >2,500m ² Gross Floor Area | |
| Stadia | >1,500 seats | |
| Housing | >100 dwellings | |

5. If any of the above thresholds are indicated as being exceeded, further information, in the form of a Transport Assessment, will require to be provided and contact should be made with Highland Council TEC Services.

Note – smaller developments may require a Transport Assessment where these are likely to have significant transport implications.

6. If the development proposal does not exceed any of the above thresholds, it is still important to understand what transport changes if any are likely to occur. Applicants should, therefore, complete the following table when the table in Q4 remains unchecked.

| | Morning Peak IN | Morning Peak OUT | Evening Peak IN | Evening Peak OUT |
|--|--------------------|---------------------|--------------------|---------------------|
| <u>Existing:</u> | | | | |
| Number of people by all modes of transport | | | | |
| Number of cars | | | | |
| Number of vans, deliveries | | | | |
| <u>Proposed:</u> | | | | |
| Number of people by all modes of transport | | | | |
| Number of cars | | | | |
| Number of vans, deliveries | | | | |

ROADS AND TRANSPORT GUIDELINES FOR NEW DEVELOPMENTS
STIÙIRIDHEAN RATHAIDEAN IS CÒMHDHAIL AIRSON LEASACHAIDHEAN ÙRA

APPENDIX 4
EÀRR-RÀDH 4

TRAVEL PLANS – GUIDANCE
PLANAICHEAN CÒMHDHALACH – STIÙIREADH

TRAVEL PLANS - GUIDANCE

Travel Plans are tailored to the specific circumstances of a location and should reflect the nature and type of development. As a minimum, a Travel Plan should include:-

- A clear statement of targets and objectives;
- An assessment of existing transport infrastructure and facilities on site;
- An assessment of the travel needs that are, or will be, generated on site. This is achieved by answering five key questions – Who? Where? Why? When? and How?
- A programme of appropriate measures that will improve accessibility and promote sustainable travel options;
- A programme for the implementation of the Travel Plan, detailing the dates by which the various measures will be put in place;
- The identification of who is responsible for actions of the implementation plan;
- The identification of how required funding will be provided;
- A firm commitment to implement the measures identified; and
- Monitoring mechanisms to ascertain progress towards achieving targets.

In terms of the five Key Questions, the Travel Plan should clearly answer and set out measures to address the following:-

Who?

Who will travel to the development? Staff, customers, users, residents, etc. this should include **how many**, and the Travel Plan should consider the most significant flows.

Where?

First, where will people travel from to the development? The catchment area for users, customers and staff should be defined.

Next, for the catchment area, where are the most accessible sites? This should be asked – and answered – at the first stage in the planning process, and an accessible location chosen. If the catchment is a town or suburb, the most accessible site may be in a residential area, to minimise walking distances, but if the catchment includes the surrounding countryside, it is more likely to be the town centre or on a key radial route, to maximise accessibility by bus.

There will obviously be constraints in many cases which will prevent use of the most accessible site but this should be understood and mitigated.

Why?

What are the journey purposes? Obvious in many cases perhaps (e.g. staff to work, customers for shopping, visitors, residents, etc) but what are the consequences for travel decisions and what is the likelihood of multi-purpose journeys in which the development is one of a few destinations? Answers to these questions will influence the type of transport provision and the likelihood of people to take up public transport and cycling options (and therefore the practicality and success of the Travel Plan).

When?

This includes what time of day/week and how often. It should include full time and part time staff and whether there is flexitime or shift working. For a retail development (and many other types e.g. hospitals and health centres) it will include opening hours and expected peak hours/seasons for business. Will the travel be frequent (e.g. daily), infrequent (e.g. monthly) or irregular?

How?

When all the above questions have been answered, it is possible to answer (a) how will people travel if no special measures are put in place? (i.e. a transport assessment), and (b) what special measures are likely to be desirable and effective? Such measures may be to the business advantage of the development (e.g. increasing footfall or turnover in a shop, or reducing “no shows” or home visits from a medical centre) as well as having a broader social benefit (improved health, limiting congestion etc).

The Council will normally request that a Travel Plan be prepared and agreed, as part of the planning process, when a TA has been required. In such cases, a Travel Plan framework should form part of the TA. The Council may also request a Travel Plan be prepared for a smaller development that may not meet the criteria for a TA, as set out in Section 2.2, but which could generate significant amounts of traffic within areas of specific concern.

In certain circumstances, for example in the case of a speculative development for which no final occupier has yet been established, the Council will request the developer prepare a Framework Travel Plan, which shall set out the general objectives and requirements of a Travel Plan and acknowledging that future occupiers will be required to sign up to these and subsequently provide a more detailed Travel Plan, tailored for their specific needs.

For residential developments, the developer will be asked to follow the principles of a Travel Plan and take actions to encourage future occupiers to consider and use sustainable modes of travel.

It will normally be the case that the requirement for a Travel Plan to be developed and implemented shall be a specific condition of a legal agreement between the developer and the Council.

It is important for a developer to understand that the production of a Travel Plan or Travel Plan framework is not simply a one-off requirement necessary to obtain planning consent. A Travel Plan is an evolving document that requires regular monitoring, review and up-dating. A Travel Plan will normally set certain targets, normally for two years after the start date of the Travel Plan, as well as agreeing to implement measures if the targets have not been reached. Subsequent monitoring will be required to assess if these measures have been successful or not.

The requirement of a Travel Plan should not be seen as an additional “burden” in the planning process, but as a tool for helping to deliver more sustainable development that can make good business sense.

Further advice and details is generally available and following are likely to provide a developer with useful information:-

- “Travel Plans: An Overview”, former Scottish Executive, 2002
<http://www.scotland.gov.uk/Publications/2002/10/15454/11007>
- “Making Residential Travel Plans Work: Guidelines for New Developments”, Department for Transport, 2005
<http://www.dft.gov.uk/pgr/sustainable/travelplans/rpt/makingresidentialtravelplans5775>
- “Transport Energy Best Practice – A Guide on Travel Plans for Developers”, Department for Transport, 2006
<http://www.dft.gov.uk/pgr/sustainable/travelplans/work/deontravelplansfordevelopers.pdf>
- “The Essential Guide to Travel Planning”, Department for Transport, 2007
<http://www.dft.gov.uk/pgr/sustainable/travelplans/work/essentialguide.pdf>
- ACT Travelwise is a network of organisations that promote sustainable travel and provides information and support. www.acttravelwise.org

ROADS AND TRANSPORT GUIDELINES FOR NEW DEVELOPMENTS
STIÙIRIDHEAN RATHAIDEAN IS CÒMHDHAIL AIRSON LEASACHAIDHEAN ÙRA

APPENDIX 5
EÀRR-RÀDH 5

ROAD CONSTRUCTION CONSENT APPLICATION FORMS

FOIRMEAN-IARRTAIS AONTA TOGAIL RATHAID

Road Construction Consent Application Form – RCC F1



| | | | | | | |
|--|-----------------|--|--|--|----------|--|
| HIGHLAND COUNCIL ROAD CONSTRUCTION CONSENT ROADS (SCOTLAND) ACT 1984 | Grid Reference | | | | | |
| | Register No. | | | | | |
| | Date of Receipt | | | | | |
| I/We hereby make application for Construction Consent for road works described on this form and on the accompanying plans. | | | | | | |
| IMPORTANT <i>You should consult the Area Roads and Community Works Manager for early advice in order to avoid delays in processing the application.</i> | | | | | | |
| 1.Full name and address of applicant. (BLOCK LETTERS) | | | | | | |
| Telephone No. | | | | | | |
| 2.Full name and address of agent (if any) acting on the applicant's behalf. (BLOCK LETTERS) | | | | | | |
| Telephone No. | | | | | | |
| 3.Location of proposed road. | | | | | | |
| 4 (a) Do the proposed road works have FULL planning permission? | | | | | YES / NO | |
| (b) If YES please give (i) planning consent reference number (ii) date of issue of consent | | | | | | |
| | | | | | | |
| | | | | | Date | |
| (c) If the answer to 4(a) is NO, has a "Full" planning application or an application for "Matters Specified in Conditions" involving the proposed road works been submitted? | | | | | YES / NO | |
| If YES please indicate whether you have made (i) a "Full" application or (ii) an application for "Matters Specified in Conditions". | | | | | | |
| | | | | | YES / NO | |
| | | | | | YES / NO | |
| Please give date of application | | | | | Date | |
| 5. State whether you have notified the proposal to all relevant Statutory Undertakers in the following fields: | | | | | | |
| Telecommunication Services | | | | | YES / NO | |
| Electricity Supply Services | | | | | YES/NO | |
| Gas Supply Services | | | | | YES / NO | |
| Water Supply Services (Scottish Water Authority) | | | | | YES / NO | |
| Street Lighting (Area Lighting Engineer, Transport, Environmental and Community Services, Highland Council) | | | | | YES / NO | |
| PLEASE COMPLETE THE APPROPRIATE LANDOWNERSHIP CERTIFICATE AND RETURN THIS FORM WITH THREE COPIES OF ALL PLANS TO THE AREA ROADS AND COMMUNITY WORKS MANAGER | | | | | | |
| RCCF1/ | | | | | | |

CONSTRUCTION CONSENT FORMS - NOTES FOR GUIDANCE

General

It will be helpful to consult the Area Roads and Community Works Manager before making an application to check that a Road Construction Consent is required. Where there is no existing planning permission for the proposed road works, applicants are advised to consult the Area Planning and Building Control Manager to ascertain whether planning permission is required. It is the applicant's responsibility to ensure that underground water mains, sewers etc., or overhead electricity lines etc., are protected or diverted in consultation with the appropriate supply authority.

Plans

Applications for Construction Consent, for which a charge based on the estimated value of the works will be made, should be accompanied by three paper copies of each of the following:-

(a) location plan preferably on an Ordnance Survey base to a scale of 1:1250 or 1:2500.

(b) A layout plan of the road network showing carriageway, footways, verges, cycletracks, footpaths, retaining walls, bridges, earthworks and other relevant detail to a minimum scale of 1:500 (1:250 or 1:200 where pedestrian/vehicle shared surfaces are proposed) and detailing:

- (i) the proposed centre, building and kerb lines and footway edges, together with relevant widths and widenings where applicable;
- (ii) curve radii of the road alignment and junctions;
- (iii) dimensioned visibility splays at road junctions, and forward visibility envelopes when these extend beyond adjacent footpaths;
- (iv) vehicular access points to properties;
- (v) pedestrian and cycle crossing points at junctions and other locations where dropped kerbs will be provided;
- (vi) the carriageway falls and the location of all road gullies;
- (vii) the location of the road surface water drainage system and its discharge points together with network design calculations;
- (viii) the location and type of lighting columns and lanterns, wall mounted lighting units (if applicable), (including any other lighting which could be construed as secondary lighting), control pillars, underground cables and road crossing ducts;
- (ix) the location of all underground services and ancillary apparatus;
- (x) the full extent of all cut and fill slopes;
- (xi) the boundaries of any areas that it is intended will subsequently be offered for adoption or maintenance;
- (xii) details of proposed road markings, traffic signs, and street name plates.

(c) A longitudinal section along the road giving vertical alignment details.

(d) Surface water drain gradients with manhole positions marked thereon.

(e) A ground investigation report depicting the nature of the substrata below road formation level or to rockhead.

- (f) Typical cross sections through the carriageways, footways and footpaths /cycleways detailing widths, crossfalls, construction depths of materials, kerb and edge details, and typical details of gullies and gully connections, together with specific sections at critical points.
- (g) Detailed drawings for any structures, bridges, culverts, retaining walls etc., along with appropriate Design and Check Certificates, which may be obtained from the Director of Transport, Environmental and Community Services;
- (h) A safety audit, when required by the Director of Transport, Environmental and Community Services;
- (i) Specification details;
- (j) A flood risk assessment which may include a hydrological report when required by the Director of Transport, Environmental and Community Services;
- (k) Details of SUDS systems when used to deal with surface water drainage and the limits and type of possible maintenance measures foreseen.

Land Ownership

The application **cannot** be registered if one or other of the Certificates regarding land ownership has not been completed.

If the applicant is not the owner of all land fronting, abutting or comprehended in the road and has therefore completed Certificate B (Form RCC F2), Notice No.1 (Form RCC F3) must be served by the applicant on all owners specified in Certificate B. Blank copies of Notice No.1 may be obtained from the Area Roads and Community Works Manager.

Service of Notice No.1 must be effected by First Class recorded delivery or Registered Post to the owner(s) of land affected. In the event that the applicant has been unable to ascertain the address of the person upon whom the notice should be served, the notice should be addressed

- (i) by name, if the name is known or
- (ii) if the owner is not known, by the description of "owner"

AND in either event delivered to some person occupying the land, or if there is no such person, by displaying a copy of the Notice on the land.

Sustainable Urban Drainage Systems

Where SUDS systems are envisaged an agreement between the Highland Council and the Scottish Water Authority in respect of maintenance of those systems will be made. A framework for such an agreement is outlined in the SUDS for Roads document.

While this framework for a maintenance agreement for new developments will apply to most developments the Highland Council reserves the right to require a Site Specific Agreement, possibly involving third parties, where developments entail major sustainable urban drainage systems and / or flood prevention measures.

The limits of maintenance requirements should be discussed with the Area Roads and Community Works Manager as early as possible in order to enable the making of an agreement as above, preferably before submission of the plans requested to accompany the application for Construction Consent as listed.

LAND OWNERSHIP DETAILS FORM – RCC F2

CERTIFICATE A

To be completed if the applicant is the owner of all the land fronting, abutting or comprehended in the proposed road.

I hereby certify that:

No person other than myself/the applicant* was an owner of any part of the land which fronts, abuts or is comprehended in the site of the proposed road at the beginning of the period of 21 days ending with the date of this application.

Signature of Applicant or Agent

Date

CERTIFICATE B

To be completed if the applicant is not the owner of all the land fronting, abutting or comprehended in the proposed road.

I hereby certify that:

I have / The applicant has* given the requisite notice to the undernoted persons being all the persons other than myself / the applicant who at the beginning of the period of 21 days ending with the date of the accompanying application were owners of the land fronting, abutting or comprehended in the site of the proposed road to which this application relates.

| Name of Owner | Address | Interest | Date of Service of Notice |
|---------------|---------|----------|---------------------------|
| | | | |

Signature of Applicant or Agent

Date

LAND OWNER NOTIFICATION FORM – RCC F3

ROADS (SCOTLAND) ACT 1984

ROAD CONSTRUCTION CONSENT APPLICATION

NOTICE No 1

LAND OWNER NOTIFICATION

Notice is hereby given that an application has been submitted for a Road Construction Consent in respect of land at

.....

in respect of which you are believed to be an owner of land fronting, abutting or comprehended within the proposed road.

Full details of the proposals and plans may be examined at the office of the Area Roads and Community Works Manager

.....

.....

.....

Any representations on this application for Construction Consent must be made in writing and submitted to the Area Roads and Community Works Manager at the above address within 28 days of the date of intimation of this notice.

Signed Date.....

This Notice is served on behalf of

.....

.....

Applicant/Agent

ROADS AND TRANSPORT GUIDELINES FOR NEW DEVELOPMENTS
STIÙIRIDHEAN RATHAIDEAN IS CÒMHDHAIL AIRSON LEASACHAIDHEAN ÙRA

APPENDIX 6
EÀRR-RÀDH 6

ROAD CONSTRUCTION CONSENT CONSTRUCTION COMPLIANCE FORM
FOIRM-GÈILLIDH AONTA TOGAIL RATHAID

RCC Construction Compliance Statement

| | | | | | | |
|--|-----------------|--|--|--|--|--|
| HIGHLAND COUNCIL ROAD CONSTRUCTION CONSENT ROADS (SCOTLAND) ACT 1984 | Grid Reference | | | | | |
| | RCC No. | | | | | |
| | Date of Receipt | | | | | |
| Name of Project | | | | | | |
| Location | | | | | | |
| IMPORTANT <i>This RCC Construction Compliance Statement must be completed and signed before the Council will formally adopt any new road, footway, footpath, etc.</i> | | | | | | |
| 1. Full name and address of applicant. (BLOCK LETTERS) | | | | | | |
| Telephone No. | | | | | | |
| 2. Construction Compliance | | | | | | |
| <p>I/We certify that all road and related works have been constructed in accordance with the issued Road Construction Consent or any subsequent approved amendment of said Consent. Works include levels and materials, together with commissioning and testing where appropriate.</p> <p>I/We certify that reasonable professional skill and care has been used in examining and supervising construction of these works.</p> | | | | | | |
| Signed | | | | | | |
| Name (Block Letters) | | | | | | |
| Name of Organisation | | | | | | |
| Position Held | | | | | | |
| Qualifications | | | | | | |
| Date | | | | | | |
| RCC CCS/2010 | | | | | | |

ROADS AND TRANSPORT GUIDELINES FOR NEW DEVELOPMENTS
STIÙIRIDHEAN RATHAIDEAN IS CÒMHDHAIL AIRSON LEASACHAIDHEAN ÙRA

APPENDIX 7
EARR-RÀDH 7

PUBLIC TRANSPORT UNIT BUS STOP SPECIFICATION
SÒNRACHADH STAD BUS CÒMHDHAIL PHOBLAICH

Public Transport Unit Bus Stop Specification

Introduction

This information sheet sets out the Highland Council's requirements for new developments, where new bus stops are provided or existing ones are upgraded. All new housing or commercial developments will be expected to be fully compliant with these conditions, unless agreed otherwise with the Council's Public Transport Unit.

Bus Stop Specification

Where a new bus stop is provided or an existing one is upgraded, in association with a development, the following measures shall usually be required:-

- Kerbs laid at suitable height for level entry (*with height to be confirmed by Public Transport Unit in conjunction with bus operators*).
- Kassel kerbs to be considered, where appropriate (*following discussion between Public Transport Unit and bus operators*).
- Suitable hard standing at stops (*including removal of cobbles, grass verges etc*).
- Dropped kerbs near the stops to allow wheelchair/pram users to cross the road.
- Sufficient room to manoeuvre a wheelchair/pram at each stop (*generally a minimum approach length of 2.4 metres*).
- Bus shelter to be provided at all stops that have significant numbers of passengers boarding (*as deemed necessary by the Council*).
- Internal lighting to be provided within any new bus shelter (*as deemed necessary by the Public Transport Unit*).
- In residential areas, bus stops should generally not be in bus bays. This may, in some circumstances, involve moving existing bus stops and/or infilling existing bus bays (*as deemed necessary by the Council*).
- Bus bays to be provided on main distributor roads and most rural roads, (*as deemed appropriate by the Council*).
- Bus boarders/build-outs to be provided where traffic calming is appropriate and/or where parking is likely to block access to the stops.
- Appropriate bus stop markings on carriageway, with related signage.
- Bus stop poles to be provided.
- Bus flags to be fixed to bus stop poles, with route numbers and Traveline details, etc.
- Timetable display cases, fixed to either the bus stop pole or bus shelter, suitably sized to accommodate all bus service details (*following discussions with the Council and bus operators*).
- Real Time Information display panels to be provided (*type to be agreed with the Council*).
- Stops generally not to be exactly opposite each other (so that road is not blocked by two buses stopped). This could be varied if overtaking is a significant hazard.

Exact requirements and details must be agreed with the Council's Public Transport Unit prior to works being implemented.

Costs

All costs associated with the installation of new bus stops or the enhancement of existing ones shall be borne by the developer, unless agreed otherwise by the Council.

ROADS AND TRANSPORT GUIDELINES FOR NEW DEVELOPMENTS
STIÙIRIDHEAN RATHAIDEAN IS CÒMHDHAIL AIRSON LEASACHAIDHEAN ÙRA

APPENDIX 8
EARR-RÀDH 8

REFUSE AND RECYCLING COLLECTION REQUIREMENTS

RIATANASAN TOGAIL SGUDAIL IS ATH-CHUAIRTEACHAIDH

Refuse and Recycling Collection Requirements

Household and Commercial Recycling Infrastructure

Introduction

This information sheet sets out The Highland Council's waste management requirements for new developments. All new housing or commercial developments will be expected to be fully compliant with these conditions.

Level of Service

In urban areas, The Highland Council operates a segregated kerbside collection service, which requires householders to deposit paper and cans for recycling into a 55 litre box, garden waste into a 240 litre bin and residual waste into a 240 litre bin. The recycle and garden waste are collected fortnightly and residual waste is collected weekly.

Rural properties are served by a weekly residual waste collection as above and a 4-weekly mixed recycle collection into a 240 litre bin.

Planned improvements to services are likely to result in all households being served by a 3-bin service in the future (1 bin for recyclables, one bin for compostables and one bin for residual waste), and any new developments should make provision for these planned service changes.

Waste and Recycling Containers

The householders or the developer are required to purchase a green 240 litre bin for residual waste. Recycling bins or boxes are provided free of charge by The Highland Council.

External Storage Space Requirements

1. All new housing developments should ensure that there is sufficient external storage space for three standard 240 litre wheeled bins per household. The minimum area required is 2m x 1m.
2. The bin area should be hardstanding, with no steps between the storage area and the collection point (kerbside).

The Highland Council recognise that in certain circumstances, for example flats, communal bins may be a preferred option; this should only be considered where individual bins are not possible. In this circumstance, two 1100 litre galvanised bins should be provided per six households (one for mixed recycle and one for residual waste). Each bin has external dimensions of approx. 1m x 1.3m. An area sufficient to store two 1100 litre bins should be provided for each group of six households.

A communal bin storage area can be used for either individual bins or communal bins. Each design will be dependent on the layout and size of the development. If a communal bin storage area is to be constructed, the following aspects should be taken into account.

- | | |
|---|---|
| <ul style="list-style-type: none"> • Adequate lighting – natural or artificial • Good natural ventilation • Smooth, easy to clean floor • Suitable drainage | <ul style="list-style-type: none"> • If roofed, height should allow bin lids to fully open • Ability to secure door in open position to allow easy movement of bins |
|---|---|

Waste Collection Point

Waste collection is offered to the householder at the kerbside. The Highland Council will not access private roads or driveways to collect waste or recycling containers. Developers should ensure sufficient space is incorporated within their development for the placement of waste containers at the kerbside on collection days, and that the route between the storage area and collection point is free from steps, kerbs or other obstructions. Particular consideration should be given to this issue where communal bins are proposed.

Dwellings on private roads

For new properties which will be served by a private road it should be noted that the collection point for waste and recycling containers will be at road-side by the adopted road. Collection vehicles will not access private roads or driveways. In these circumstances a road-end collection point should be designed to store the bins awaiting collection.

Road standards

Road design and layout standards must take account of the access requirements of refuse collection vehicles. These have been incorporated into the Council's "Roads and Transport Guidelines for New Development" document, which developers should consult. Road layouts should be designed so that collection vehicles do not need to reverse on the public road.

Developers should note that waste collection vehicles will not access roads that do not meet the standard for adoption. For phased developments, where properties are to be occupied prior to the adoption of roads, it may be necessary to make temporary arrangements for the storage and collection of waste containers at the boundary of the development.

Centralised recycling facilities for new housing developments

Sufficient space is required to accommodate a centralised recycling point for developments with 100 or more properties. A recycling point consists of glass (x3), paper, can and textile banks (total external dimensions approx. 12m x 5m.) Recycling points should be sited on a hard standing within public space. Access requirements by collection vehicles (articulated lorry) should be taken into account. The recycling point should be located in an easy to reach, visible location.

New Commercial Developments

Commercial sites vary greatly, dependent on business type and size. Commercial properties will be expected to recycle, therefore multiple bins/storage containers are likely to be required. An area of hard standing should be provided and dropped kerbs as necessary to permit safe handling to and from collection and storage points.

For further information and advice on Refuse and Recycling collection requirements please contact:

- Inverness, Nairn and Badenoch and Strathspey
Operations Manager – Waste
Tel: 01463 245780
- Ross, Skye and Lochaber
Operations Manager – Waste
Tel: 01349 868440
- Caithness, Sutherland and Easter Ross
Operations Manager – Waste
Tel: 01995 607737

ROADS AND TRANSPORT GUIDELINES FOR NEW DEVELOPMENTS
STIÙIRIDHEAN RATHAIDEAN IS CÒMHDHAIL AIRSON LEASACHAIDHEAN ÙRA

APPENDIX 9
EARR-RÀDH 9

ABNORMAL LOADS

EALLAICHEAN NEO-ÀBHAISTEACH

ABNORMAL LOADS

Legislation

Abnormal loads are defined as those laden dimensions that exceed one or more of the following criteria:-

- 2.9 metre overall width
- 18.3 metre rigid length
- 44 tonne gross weight

The control of abnormal indivisible loads is regulated and controlled by legislation:-

- Part II of the Road Traffic Act 1988
- Road Vehicles (Authorisation of Special Types)(General) Order 2003
- Road Vehicles (Construction and Use) Regulations 1986
- Special Orders

The movement of certain types of abnormal load is illegal unless authorised by Scottish Ministers, who will grant “VR1” or “Special Order” approval. Some load types also require notice to be given to the Police, Road and Bridge Authorities.

In Scotland, the Transport Scotland Abnormal Routing Section co-ordinates the movement of abnormal loads on both the Trunk Road and non-Trunk Road networks and must be satisfied that the movement is justified and that alternative routes have been considered, in consultation with interested bodies, including the relevant Local Roads Authority. The Section can provide a routing advisory service as well as informing which proposed wide, high or heavy load movements will require Scottish Ministers’ authorisation, as different dimensions require different approvals. Authorisation from all relevant authorities must be obtained before an abnormal load can be moved. Further information on abnormal loads can be obtained from the Transport Scotland website (<http://www.transportscotland.gov.uk/road/bridges-and-structures/abnormal-load-routing>).

Where an abnormal load will use roads within the Highlands region, early discussions must be held with the Council.

Height of Loads

There is no current legislation to restrict the height of vehicles, so there is no specific need to seek approval for high vehicles. The standard minimum headroom clearance is 5.03m and it is the responsibility of the **driver** to ensure that the height of the vehicle can pass beneath all overbridges or any other obstacles that restrict height.

However, as a result of an increase in bridge strike incidents, Transport Scotland’s website provides a list and map of all Trunk Road overbridges that have been hit by vehicles or have sub-standard heights, to help inform operators of potential route restrictions. For the local road network, the relevant Local Roads Authority should be contacted for information on low bridges.

Movement of Abnormal Loads

From 1 January 2004, self-escorting of abnormal loads was introduced and there is now no requirement to have a police escort, as was previously the case although for certain abnormal loads, there is a requirement to give advance notice to the Police. In addition, if specific traffic management is required, such as the need to stop or temporarily re-direct traffic, then prior arrangements must be made with the relevant Police Force, as they will undertake these tasks.

The **Notified Route** is authorised by the relevant authorities and this is the only route that will be allowed to be used and authorisation may include certain timetable restrictions. Prior to transferring an abnormal load, it is good practice to undertake a trial run and video the route, as this can aid the assessment of any likely improvements.

The Highways Agency has published **Code of Practice for Self Escorting** (HA74/05) and also **Operating Guidance for Abnormal Load Escorting**, which both provide relevant advice.

The Code of Practice requires a private escort person or firm to be competent, through training and/or experience. Having knowledge of the relevant local road network is an obvious advantage.

Guidelines for self escorting of abnormal loads have also been published by The Association of Chief Police Officers in Scotland (ACPOS). Whilst the guidelines mainly relate to motorways and dual carriageways, they also provide useful general information. Significant requirements are:-

- Highlighting that haulier shall comply with the HA Code of Practice HA74/05;
- Haulier to provide written notice that personnel will not engage in the direction or control of general traffic; and
- Haulier must give assurance not to operate or move loads on urban motorways during peak traffic flows.

Route Assessment

If the **Notified Route** includes minor or locally busy roads, it is recommended that a survey is undertaken beforehand, to identify any key issues. Some routes may also require Swept Path Analysis to be undertaken in order to demonstrate that the abnormal load can negotiate the roads. In some cases, this may lead to a requirement for temporary realignments or alterations to be undertaken including but not restricted to:-

- Carriageway widening
- Removal/widening of bends or corners
- New passing places
- Temporary removal of roundabouts
- Walls or fences to be taken down or relocated
- Bridge parapets removed or lowered
- Bridge/culvert strengthening
- Removal or relocation of street furniture
- Trees or vegetation to be removed or cut back

There may also be a requirement to co-ordinate local delivery times, in order to minimise impact on road users. For example, avoiding peak traffic times, school activities or other traffic-generating events would need to be taken into account and discussed with the Council.

Legal Agreements

If the delivery of abnormal loads requires a developer to undertake improvements (either temporary or permanent) to some of the roads, the Council is likely to require the developer to enter into a legal agreement, usually in terms of Section 48 of the Roads (Scotland) Act 1984 or any other suitable legal agreement as approved by the Council.

If the development is likely to require a significant number of abnormal loads that could result in damage to existing public roads, the Council may require the developer to enter into a legal agreement, under the terms of Section 96 of the Roads (Scotland) Act 1984.

Indemnity

Operators should be aware that heavy abnormal loads need to indemnify the relevant Roads and Bridges Authorities for any resulting damage to roads and structures.

ROADS AND TRANSPORT GUIDELINES FOR NEW DEVELOPMENTS
STIÙIRIDHEAN RATHAIDEAN IS CÒMHDHAIL AIRSON LEASACHAIDHEAN ÙRA

APPENDIX 10
EÀRR-RÀDH 10

ACCESS TO SINGLE HOUSES AND SMALL DEVELOPMENTS

SLIGHEAN-INNTRIGIDH GU TAIGHEAN SINGILTE AGUS LEASACHAIDHEAN BEAGA

Please use the following link :-

<http://www.highland.gov.uk/NR/rdonlyres/042D2DA8-24CA-45F2-B5CF-B720F51C00BB/0/AccessToSingleHousesMay2011.pdf>

ROADS AND TRANSPORT GUIDELINES FOR NEW DEVELOPMENTS
STIÙIRIDHEAN RATHAIDEAN IS CÒMHDHAIL AIRSON LEASACHAIDHEAN ÙRA

APPENDIX 11
EÀRR-RÀDH 11

ACCESS FOR FORESTRY EXTRACTION

SLIGHE AIRSON ÀS-THARRAING COILLTEARACHD

HIGHLAND COUNCIL

TEC SERVICES

TECHNICAL ADVICE NOTE FORESTRY EXTRACTION

Director of TEC Services

Highland Council
Glenurquhart Road
INVERNESS
IV3 5NX

May 2013

TECHNICAL ADVICE NOTE

1.0 FORESTRY EXTRACTION

- 1.1 This note is intended to provide advice on the provision of new or improved access to public roads for forestry extraction purposes.
- 1.2 Planning consent is necessary for any new access on classified roads. Significant improvement or alteration to an existing access may also require planning consent. Developers should contact the Planning and Development Service for guidance on planning requirements; **however, a Road Opening Permit must be obtained from the appropriate Area Roads and Community Works Manager for any new or improved access connecting to a public road.** The advice given in this technical note is given without prejudice to the decision of the planning authority in respect of any planning application.
- 1.3 Appendix A gives typical layout drawings for forestry access and transfer points adjacent to public roads.
- 1.4 Appropriate visibility splays defined by dimensions X and Y shall be agreed with the roads authority. The splay dimensions will be dependent upon the speed of traffic on the public road, the scale of extraction or development proposed and the category of the public road. Within the visibility splays nothing shall obscure visibility between a driver's eye height of 1.05 metres anywhere along the X dimension and an object height of 0.6 metres anywhere along the Y dimension..
- 1.5 Any roadside ditch or drain shall be cleared out as necessary and a suitable culvert of 300 mm min. dia. shall be provided across the access. **The actual type and size of the culvert, details of headwalls and any invert protection required must be agreed with the appropriate Area Roads and Community Works Manager.**
- 1.6 Construction of the access bellmouth shall consist of a minimum thickness of 350mm Type 1 sub-base material, all on a sound formation, laid and shaped so that surface water from the access will not discharge onto the public road or from the public road onto the access. A 3 metre wide strip from the edge of the public road over the full width of the bellmouth shall be finished with a minimum of 40mm thick 14mm nominal size close graded asphalt concrete Surface Course to Clause 912 of the Specification for Highway Works, laid on 60mm thick 20mm nominal size dense asphalt concrete Binder Course to Clause 906 of the Specification of Highway Works..
- 1.7 The gradient of the access for the first 6 metres back from the edge of the public road should not be in excess of 2.5% (1 in 40).
- 1.8 It may also be necessary in the interest of road safety for the developer to provide edge of carriageway markings at the access junction. The requirement and specification can be obtained from the appropriate Area Roads and Community Works Manager..

1.9 Entrance gates, if any, shall not be less than 15 metres from the edge of the carriageway and shall open away from the carriageway only.

1.10 Adequate parking space shall be provided within the site for all vehicles used in connection with the work. Sufficient turning space shall be provided to enable all vehicles to leave and join the public road in a forward gear.

2.0 OPERATIONAL ADVICE

2.1 **The operator as defined by Section 96 of the Roads (Scotland) Act 1984 (Reprinted 1994) will be required to meet the cost of any above average road maintenance expenditure resulting from traffic movements associated with the timber extraction operation.** In addition specific damage to structures will be held to be the responsibility of the operator. It would therefore be advisable to agree with the Area Roads and Community Works Manager, prior to the operation commencing, the condition of the road and basis upon what damage arising will be assessed.

2.2 It is the Operator's responsibility to ensure that any mud, silt or loose material deposited on the public road, arising from the operations of vehicles or plant entering and leaving the site, are removed as soon as reasonably practicable.
Failure to do so could constitute an offence under Section 96 of the Roads (Scotland) Act 1984

2.3 Prior permission is required, if the operator wishes to load, stack or unload timber or materials within the public road boundary. An appropriate permit must be obtained from the Area Roads and Community Works Manager; failure to do so may constitute an offence under Section 59 of the Roads (Scotland) Act 1984.

2.4 Where roadwork signing and traffic control is required this should comply with the requirements of Chapter 8 of the Traffic Signs Manual. A method statement should be forwarded, along with the permit application, to the Area Roads & Community Works Manager for approval prior to the commencement of any felling or extraction of timber.

2.5 Roadside trees should not be left in isolation when a whole area is being cleared as a risk of trees being blown onto the public road will remain.

2.6 Care should be taken when clearing slopes above a road so that increased groundwater plus surcharge of trees felled and/or standing does not precipitate slip failure in the slopes below.

Appendix A

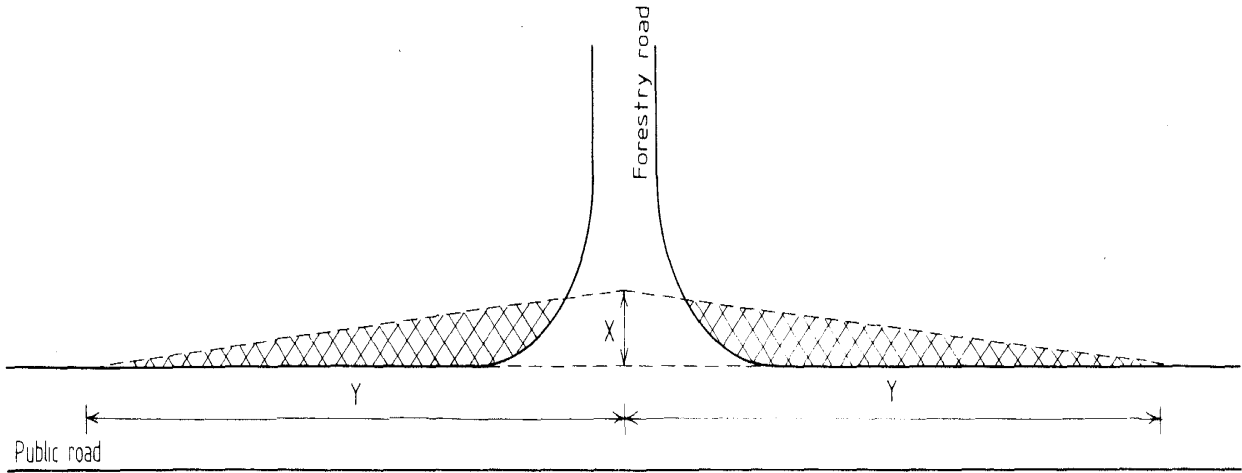

Diagram 1
VISIBILITY SPLAYS

| Indicative Visibility Splays:- No obstructions exceeding 0.6 metres above adjacent road level. | | | | | | |
|---|---|-----|-----|----|----|--|
| Speed on public road _kph | 100 | 85 | 60 | 50 | 30 | |
| Speed on public road _mph | 60 | 50 | 40 | 30 | 20 | |
| Distance Y metres | 215 | 160 | 120 | 90 | 60 | |
| Distance X metres | 9m, may be reduced to 4.5m in difficult circumstances, subject to approval by Area Roads and Community Works Manager | | | | | |

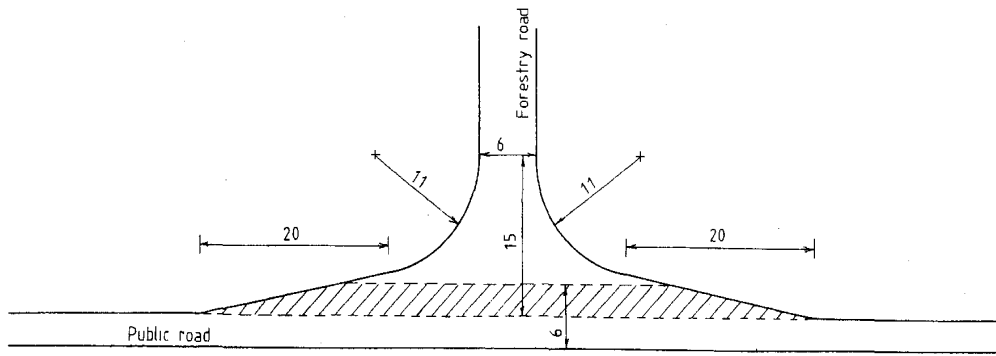

Diagram 2
ACCESS ONTO SINGLE TRACK ROAD

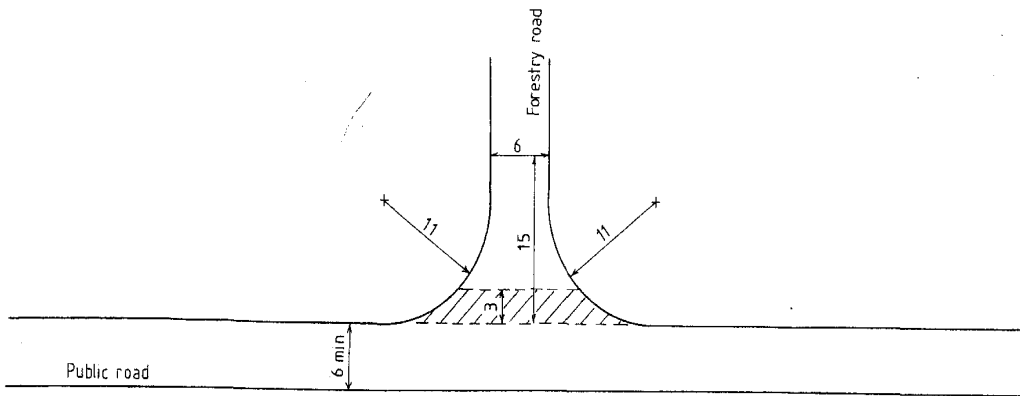

Diagram 3
ACCESS ONTO SINGLE CARRIAGEWAY

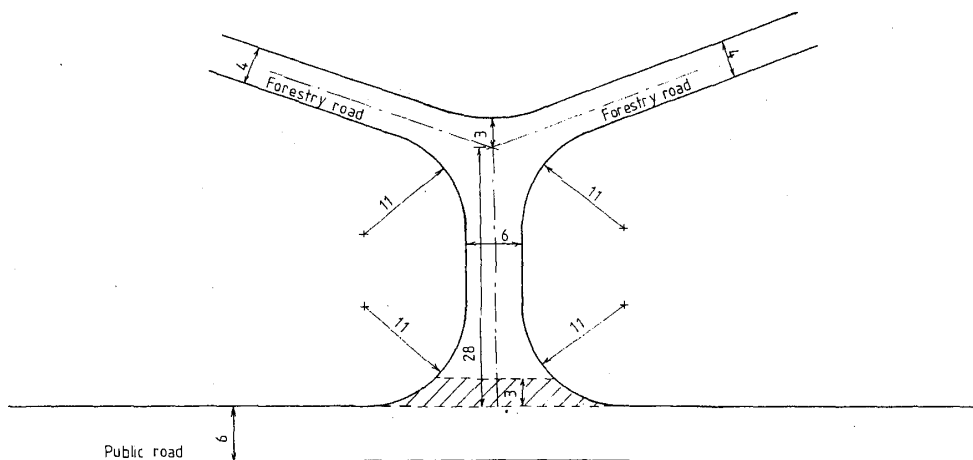

Diagram 4
FORESTRY TRANSFER POINT
(Shown used with Diagram 3)

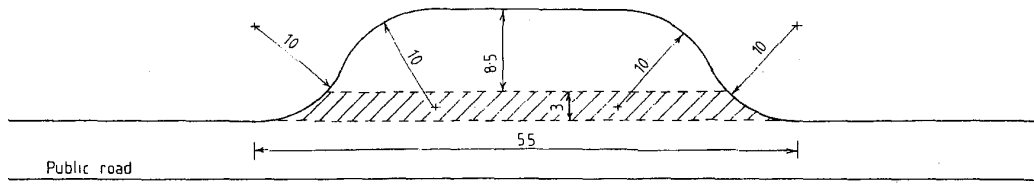

Diagram 5
LOADING BAY

Notes:

1. No other works shall commence within the site until the access from the public road has been formed or improved to the dimensions shown in the appropriate diagrams, and the required visibility splays have been provided in full..
2. Lip of bellmouth to be shaped such that surface water does not access onto the public road. Saw cut edge required at joint with public road.
3. Services to be carried under road in accordance with the specifications of the Authority concerned.
4. 3 metres wide strip to be finished with 100mm thick bound surfacing material.. Refer to Technical Advice note 1.6.
5. All dimensions in metres unless otherwise stated.
6. All drawings digitally reproduced, do not use to scale

ROADS AND TRANSPORT GUIDELINES FOR NEW DEVELOPMENTS
STIÙIRIDHEAN RATHAIDEAN IS CÒMHDHAIL AIRSON LEASACHAIDHEAN ÙRA

APPENDIX 12
EÀRR-RÀDH 12

PARKING PLACES FOR DISABLED PERSONS

ÀITEACHAN PARCAIDH DO DHAOINE CIORRAMACH

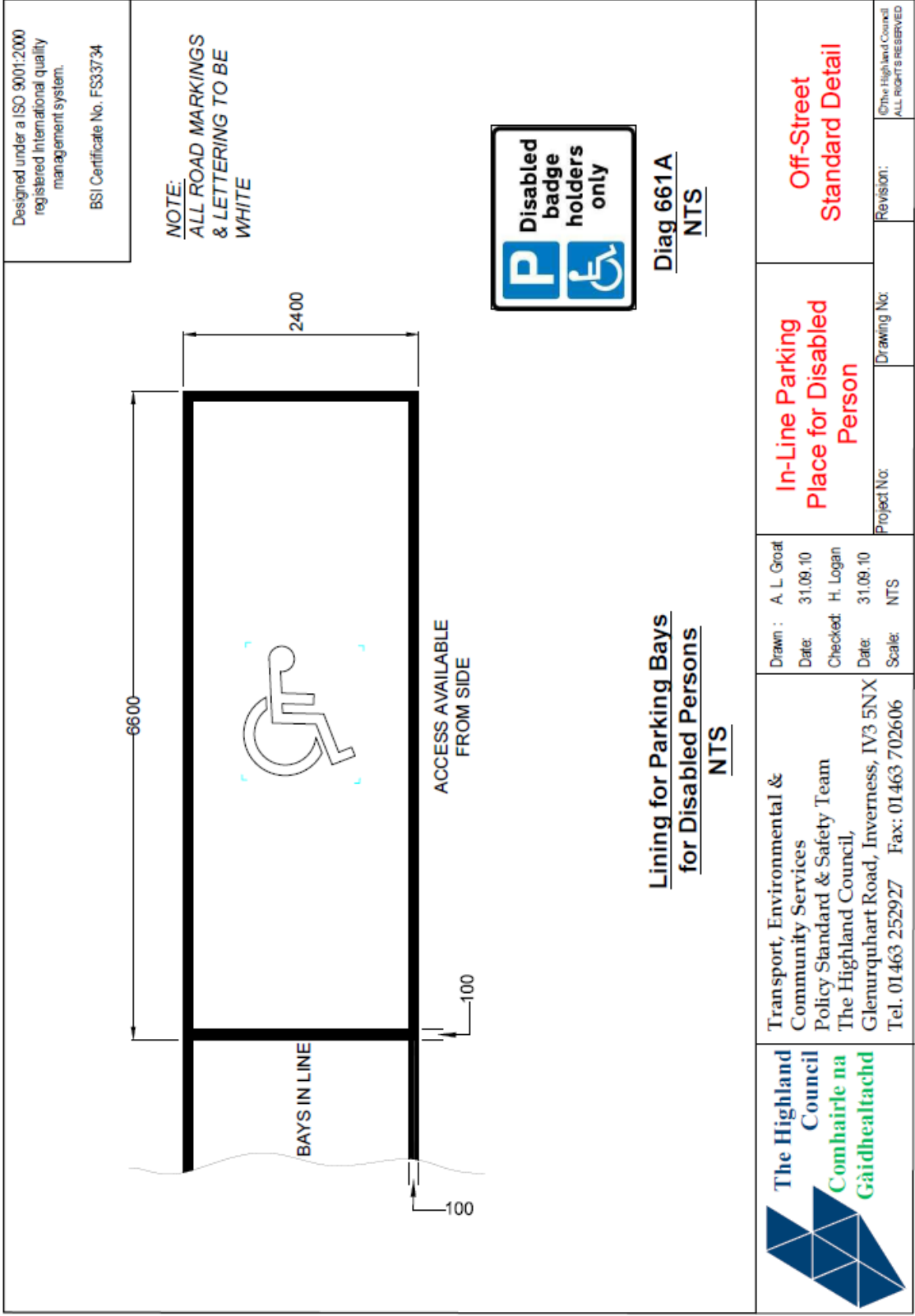

Designed under a ISO 9001:2000 registered International quality management system.
BSI Certificate No. FS33734

| | | | | |
|--|--|---|--|--|
|  <p>The Highland Council Comhairle na Gàidhealtachd</p> | <p>Transport, Environmental & Community Services Policy Standard & Safety Team The Highland Council, Glenurquhart Road, Inverness, IV3 5NX Tel. 01463 252927 Fax: 01463 702606</p> | <p>Drawn : A. L. Groat Date: 31.09.10 Checked: H. Logan Date: 31.09.10 Scale: NTS</p> | <p>In-Line Parking Place for Disabled Person</p> <p>Project No: _____ Drawing No: _____</p> | <p>Off-Street Standard Detail</p> <p>Revision: _____</p> <p>©The Highland Council ALL RIGHTS RESERVED</p> |
|--|--|---|--|--|

Designed under a ISO 9001:2000 registered International quality management system.

BSI Certificate No. FS33734

NOTE:
ALL ROAD MARKINGS & LETTERING TO BE WHITE

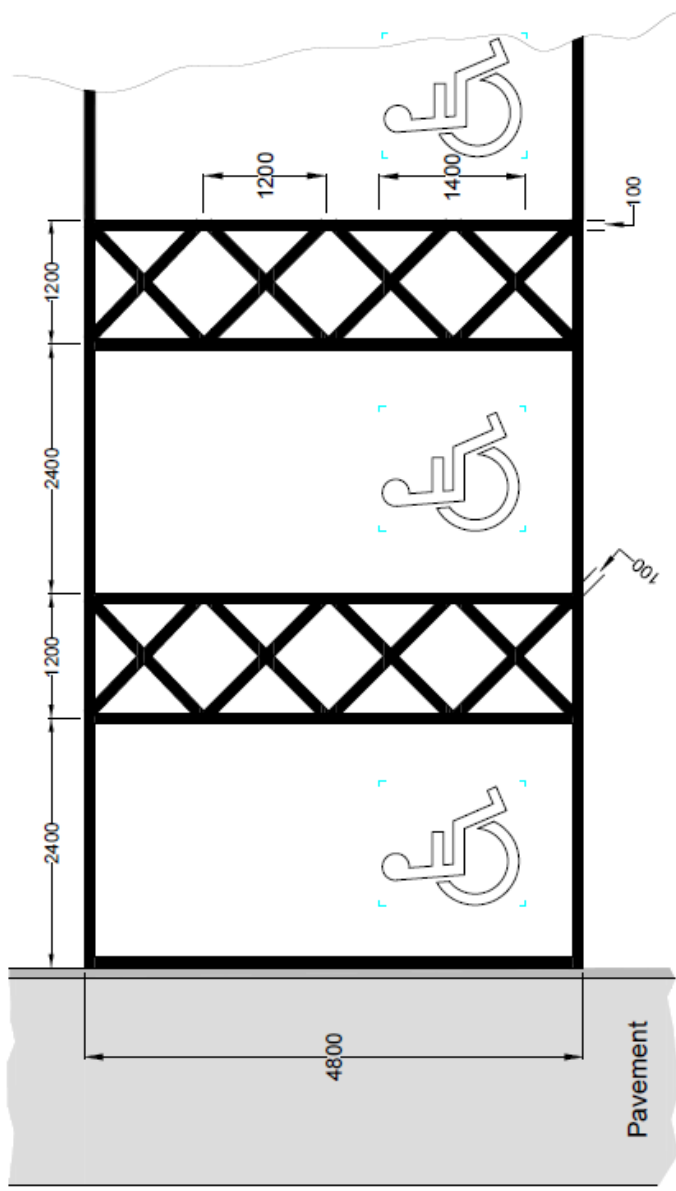

Diag 661A
NTS

Lining for Off Street Parking
Bays for Disabled Persons
NTS



Transport, Environmental & Community Services
Policy Standards & Safety Team
The Highland Council
Glenurquhart Road, Inverness, IV3 5NX
Tel. 01463 252927 Fax: 01463 702606

Drawn : A. L. Groat
Date: 31.08.10
Checked: H. Logan
Date: 31.08.10
Scale: NTS

Parking Place for Disabled Person

Off Street Standard Detail (Option 2)

Project No:
Revision:
Drawing No:
©The Highland Council
ALL RIGHTS RESERVED

Designed under a ISO 9001:2000 registered international quality management system.

BSI Certificate No. FS33734

NOTES:

1. T.S.R.G.D. layouts take precedence over any variance noted in this drawing
2. Double transverse markings used only at ends of parking bay block.
3. Double transverse markings may be omitted when marking is in a layby or the end of the bay is delineated by a raised kerb.
4. ALL ROAD MARKINGS & LETTERING TO BE WHITE

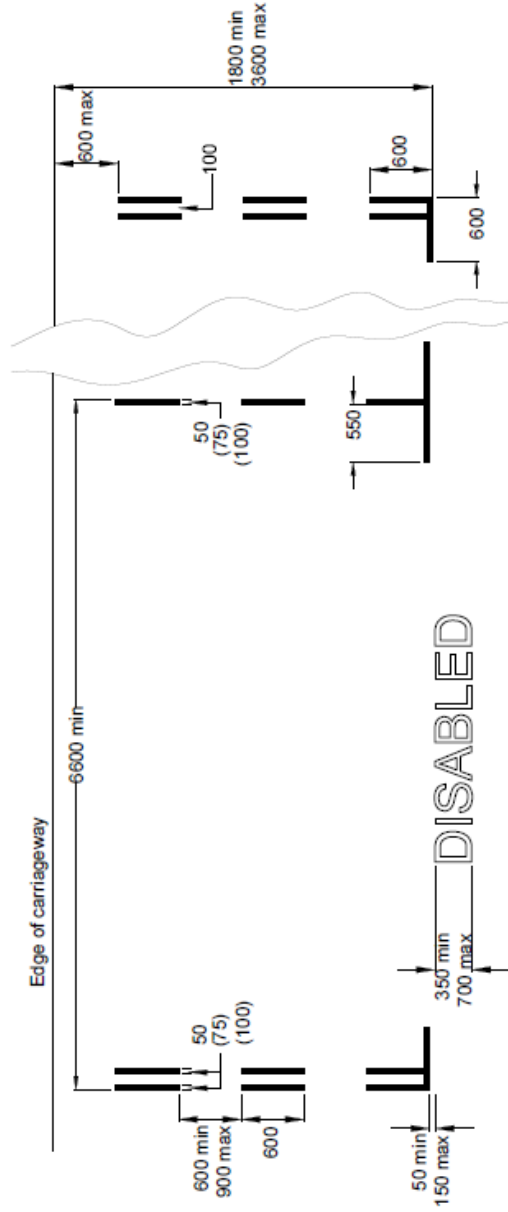

**Lining for Multiple Parking
End Bay for Disabled Persons**
NTS



Diag 661A
NTS



Transport, Environmental & Community Services
Policy Standards & Safety Team
The Highland Council
Glenurquhart Road, Inverness, IV3 5NX
Tel: 01463 252927 Fax: 01463 702606

Drawn: A. L. Groat
Date: 01.05.12
Checked: H. Logan
Date: 01.05.12
Scale: NTS

Parking Place for Disabled Person

Project No:
Drawing No:
TSRGD Diag 1032

Revision:
A
©The Highland Council
ALL RIGHTS RESERVED

**On Street
Multiple Bays
Standard Detail**

Designed under a ISO 9001:2000 registered international quality management system.
BSI Certificate No. FS33734

NOTES:

1. T.S.R.G.D. layouts take precedence over any variance noted in this drawing
2. Double transverse markings used only at ends of parking bay block.
3. Double transverse markings may be omitted when marking is in a layby or the end of the bay is delineated by a raised kerb.
4. ALL ROAD MARKINGS & LETTERING TO BE WHITE



Diag 661A
NTS

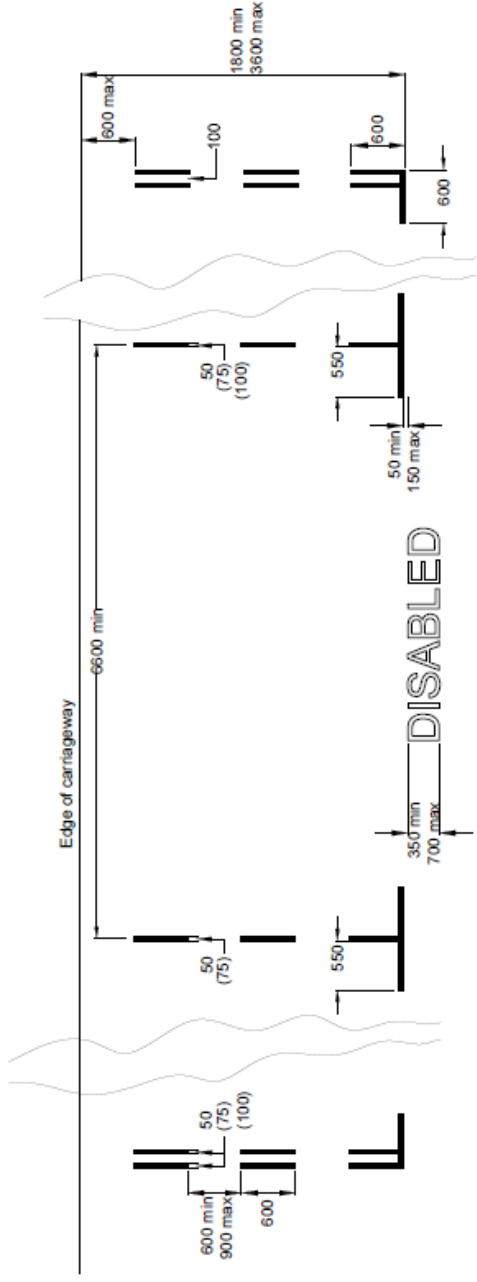

Lining for Multiple Parking
Middle Bay for Disabled Persons
NTS



Transport, Environmental & Community Services
Policy Standards & Safety Team
The Highland Council
Glenurquhart Road, Inverness, IV3 5NX
Tel. 01463 252927 Fax: 01463 702606

Drawn: A. L. Groat
Date: 01.05.12
Checked: H. Logan
Date: 01.05.12
Scale: NTS

Parking Place for Disabled Person

On Street Multiple Bays Standard Detail

Project No: TSRGD Diag 1032
Drawing No: A
Revision: A
©The Highland Council ALL RIGHTS RESERVED

ROADS AND TRANSPORT GUIDELINES FOR NEW DEVELOPMENTS **STIÙIRIDHEAN RATHAIDEAN IS COMHDHAIL AIRSON LEASACHAIDHEAN ÙRA**

BIBLIOGRAPHY **CLÀR-LEABHRAICHEAN**

Readers are advised that it is important to check if any document has been subsequently amended or withdrawn.

Web-links were correct as of September 2009 but may be subject to change outwith the control of Highland Council, unless a Council document.

Scottish Planning Policy, Scottish Government, 2010
<http://www.scotland.gov.uk/Topics/Built-Environment/planning/National-Planning-Policy/newSPP>

Planning Advice Note 75: Planning for Transport, Former Scottish Executive, 2005
<http://www.scotland.gov.uk/Publications/2005/08/16154453/44538>

Transport Assessment and Implementation: A Guide, Former Scottish Executive, 2005
<http://www.scotland.gov.uk/Publications/2005/08/1792325/23264>

The Roads (Scotland) Act 1984, UK Government, 1984
http://www.opsi.gov.uk/RevisedStatutes/Acts/ukpga/1984/cukpga_19840054_en_1

Designing Streets, Scottish Government, 2010
<http://www.scotland.gov.uk/Publications/2010/03/02113940/0>

Design Manual for Roads and Bridges, Highways Agency, 1992
<http://www.standardsforhighways.co.uk/>

The Highland Structure Plan, The Highland Council, 2001
[http://www.highland.gov.uk/yourenvironment/planning/developmentplans/structureplan/thehighlandstructu
replan.htm](http://www.highland.gov.uk/yourenvironment/planning/developmentplans/structureplan/thehighlandstructu
replan.htm)

Local Plans, The Highland Council, various dates
<http://www.highland.gov.uk/yourenvironment/planning/developmentplans/localplans/>
(September 2009 – the Council is currently preparing its new **Highland-Wide Local Development Plan** and this will in due course replace the Structure Plan and current Local Plans.)

Local Transport Strategy, The Highland Council,
[http://www.highland.gov.uk/yourenvironment/roadsandtransport/transportplanning/localtransportstrategy.h
tm](http://www.highland.gov.uk/yourenvironment/roadsandtransport/transportplanning/localtransportstrategy.htm)

Designing for Sustainability in the Highlands, The Highland Council, 2006
[http://www.highland.gov.uk/yourenvironment/planning/developmentplans/developmentplanpolicyguidance
/designingforsustainability.htm](http://www.highland.gov.uk/yourenvironment/planning/developmentplans/developmentplanpolicyguidance
/designingforsustainability.htm)

Development Management Guidance, Transport Scotland, 2007
<http://www.transportscotland.gov.uk/reports/publications-and-guidance/road/j8508-01.htm>

Circular 5/2009 – Hierarchy of Developments, Scottish Government, 2009
<http://www.scotland.gov.uk/Resource/Doc/278390/0083657.pdf>

Cycling by Design, former Scottish Executive, 2000
<http://www.scotland.gov.uk/library2/cbd/cbd-00.asp>
(September 2009 – new version is being prepared.)

Disability Discrimination Act 2005, UK Parliament, 2005

http://www.opsi.gov.uk/acts/acts2005/ukpga_20050013_en_1.htm

Inclusive Mobility: A Guide to Best Practice, Department of Transport, 2002

<http://www.dft.gov.uk/transportforyou/access/peti/inclusivemobility>

Planning Advice Note 78 – Inclusive Design, Scottish Government, 2006

<http://www.scotland.gov.uk/Resource/Doc/95636/0023150.pdf>

Disability Discrimination Act - Good Practice Guide for Roads, Transport Scotland, 2009

<http://www.transportscotland.gov.uk/reports/road/j11185-00.htm>

New Roads and Street Works Act 1991, UK Government, 1991

http://www.opsi.gov.uk/ACTS/acts1991/Ukpga_19910022_en_1.htm

Sewerage (Scotland) Act 1968, UK Government

http://www.opsi.gov.uk/RevisedStatutes/Acts/ukpga/1968/cukpga_19680047_en_1

Sewers for Scotland 2, Scottish Water,

http://www.scottishwater.co.uk/portal/page/portal/SWE_PGP_CONNECTIONS/SWE_CORP_CONNECTIONS/SWE_CONN_SUDS

SUDS for Roads, SCOTS, 2009

<http://www.scotsnet.org.uk/>

HD 19/03 Road Safety Audit, Design Manual for Road and Bridges, 2003

<http://www.standardsforhighways.co.uk/dmr/b/vol5/section2/hd1903.pdf>

The Security for Private Road Works (Scotland) Regulations 1985, UK Government, 1985

No web-link available

The Security for Private Road Works (Scotland) Amendment Regulations 1998, UK Government, 1998

<http://www.opsi.gov.uk/si/si1998/19983220.htm>

Construction (Design and Management) Regulations 2007, UK Government, 2007

http://www.opsi.gov.uk/si/si2007/uksi_20070320_en_1

The Specification for the Lighting of Roads in Housing and Developments, The Highland Council
Available from THC Lighting Engineer

Town and Country Planning (Scotland) Act 1997, UK Government, 1997

http://www.opsi.gov.uk/acts/acts1997/ukpga_19970008_en_1

The Local Authorities' Traffic Order (Procedure) (Scotland) Regulations 1999 (LA Order Procedure), UK Government, 1999

http://www.oqps.gov.uk/legislation/uk/si/si1999/uksi_19990614_en_1

Permanent Road Traffic Orders, The Highland Council

Available from THC TEC Services

Transport (Scotland) Act 2001, UK Government, 2001

http://www.opsi.gov.uk/legislation/scotland/acts2001/pdf/asp_20010002_en.pdf

The Home Zones (Scotland) (No.2) Regulations 2002, Scottish Parliament, 2002

<http://www.opsi.gov.uk/legislation/scotland/ssi2002/20020292.htm>

Designing for Deliveries, Freight Transport Association,

<http://www.fta.co.uk/>

Roads (Traffic Calming) (Scotland) Regulations 1994, UK Government, 1994

http://www.opsi.gov.uk/si/si1994/uksi_19942488_en_1.htm

The Road Humps (Scotland) Regulations 1998, UK Government, 1998
http://www.oqps.gov.uk/legislation/uk/si/si1998/uksi_19981448_en_1

The Road Humps and Traffic Calming (Scotland) Amendment Regulations 1999, UK Government, 1999
http://www.oqps.gov.uk/legislation/uk/si/si1999/uksi_19991000_en_1

The Road Humps and Traffic Calming (Scotland) Amendment Regulations 2002, UK Government, 1999
<http://www.opsi.gov.uk/legislation/scotland/ssi2002/20020419.htm>

ETLLD Circular No. 1/2006 – Setting Local Speed Limits, Scottish Government, 2006
<http://www.scotland.gov.uk/Publications/2006/08/14134225/0>

Traffic Calming Techniques, Institution of Highways and Transportation, 2005
<http://www.iht.org/>

Local Transport Note 02/08 – Cycling Infrastructure Design, Department for Transport, 2008
<http://www.dft.gov.uk/pgr/roads/tpm/ltnotes/ltn208.pdf>

TD 42/95 Geometric Design of Majority/Minor Priority Junctions, DMRB, 1995
<http://www.standardsforhighways.co.uk/dmr/vol6/section2/td4295.pdf>

TA 68/96 The Assessment and Design of Pedestrian Crossings, DMRB, 1996
<http://www.standardsforhighways.co.uk/dmr/vol8/section5/ta6896.pdf>

LTN 1/95 The Assessment of Pedestrian Crossings, Department for Transport, 1995
<http://webarchive.nationalarchives.gov.uk/+http://www.dft.gov.uk/pgr/roads/tpm/tal/signsandsignals/pedestriancrossingassessment4096>

LTN 2/95 The Design of Pedestrian Crossings, Department for Transport, 1995
<http://webarchive.nationalarchives.gov.uk/+http://www.dft.gov.uk/pgr/roads/tpm/tal/signsandsignals/pedestriancrossingassessment4096>

Guidance on the Use of Tactile Paving Surfaces, Department of Transport
<http://www.dft.gov.uk/transportforyou/access/peti/guidanceontheuseoftactilepav6167>

Local Transport Note 2/09 – Pedestrian Guardrailing, Department for Transport, 2009
<http://www.dft.gov.uk/pgr/roads/tpm/ltnotes/ltn209pedestrian.pdf>

Building (Scotland) Regulations, SBSA, 2007
http://www.sbsa.gov.uk/tech_handbooks/tbooks2007.htm

Guidelines for Reducing Mobility Handicaps, IHT
<http://www.iht.org.uk/>

Colour, contrast and perception – design guidance for internal built environments, Reading University, 2004
<http://www.reading.ac.uk/ie/news/news.htm>

BS 8300 Design of Buildings, British Standards Institution, 2009
<http://www.bsigroup.co.uk/>

Traffic Signs Manual, Department of Transport, 2006
<http://www.dft.gov.uk/pgr/roads/tss/tsmanual/>

The Traffic Signs Regulations and General Directions, UK Government, 2002
<http://www.opsi.gov.uk/si/si2002/20023113.htm>

The Sign Design Guide, Sign Design Society, 2000
http://www.signdesignsociety.co.uk/content.php?folder_id=20

BS 5489 Code of Practice for the Design of Road Lighting, BSI, 2003
<http://www.bsigroup.co.uk/>

Traffic Advisory Leaflet 10/93 Toucan – An Unsegregated Crossing for Pedestrians and Cyclists,
Department for Transport, 1993
http://www.dft.gov.uk/adobepdf/165240/244921/244924/TAL_10-93

Traffic Advisory Leaflet 3/03 Equestrian Crossings, Department for Transport, 2003
<http://www.dft.gov.uk/pgr/roads/tpm/tal/signsandsignals/pedestrianfacilities/strianfacilitiesatsignal4099.pdf>

TA 57/87 Roadside Features, DMRB
<http://www.standardsforhighways.co.uk/dmr/vol6/section3/ta5787.pdf>

A Guide to the Surfacing of Bridleways and Horse Tracks, British Horse Society
<http://www.bhs.org.uk/>

BS 5906 Waste Management in Buildings Code of Practice, BSI, 2005
<http://www.bsigroup.co.uk/>

BS EN12899-1:2007 Fixed Vertical Road Traffic Signs, BSI, 2007
<http://www.bsigroup.co.uk/>

BS 8442 Road Traffic Signs and Internally Illuminated Bollards, BSI
<http://www.bsigroup.co.uk/>

BS EN 12767 – Passive Safety of Support Structures for Road Equipment, BSI
<http://www.bsigroup.co.uk/>

BS EN 1436 Road Marking Materials, BSI
<http://www.bsigroup.co.uk/>

Specification for Highway Works, Highways Agency
<http://www.standardsforhighways.co.uk/mchw/vol1/index.htm>

BS EN 13201 Road Lighting, BSI
<http://www.bsigroup.co.uk/>

TD50/04 The Geometric Layout of Signal-Controlled Junctions and Signalised Roundabouts,
DMRB
<http://www.standardsforhighways.co.uk/dmr/vol6/section2/td5004.pdf>

TA 84/06 Code of Practice for Traffic Control and Information Systems for All-Purpose Roads,
DMRB
<http://www.standardsforhighways.co.uk/dmr/vol8/section1/ta8406.pdf>

TAL 01/02 The Installation of Puffin Pedestrian Crossings, Department of Transport, 2002
<http://www.dft.gov.uk/adobepdf/165240/244921/244924/TAL1-02.pdf>

TAL 5/05 Pedestrian Facilities at Signal-Controlled Junctions, Department for Transport, 2005
<http://www.dft.gov.uk/pgr/roads/tpm/tal/signsandsignals/pedestrianfacilities/strianfacilitiesatsignal4099.pdf>

Traffic Advisory Leaflet 06/01 Bus Priority, Department of Transport, 2006
<http://www.ukroads.org/webfiles/TAL%206-01%20Bus%20Priority.pdf>

The SUDS Manual C697, CIRIA, 2007
<http://www.ciria.org/acatalog/C697.html>

LR277 The Hydraulic Efficiency and Spacings of BS Road Gullies, TRL
<http://www.trl.co.uk/>

BRE Digest 365 Soakaways, Building research Establishment, 1991

<http://www.bre.co.uk/>

R156 Infiltration Drainage – Manual of Good Practice, CIRIA, 1996

<http://www.ciria.org/acatalog/R156.html>

TD 19/06 Requirements for Road Restraint Systems, Highways Agency

<http://www.standardsforhighways.co.uk/dmrb/index.htm>

Transport in the Urban Environment, IHT

<http://www.iht.org/>

Disabled Persons' Parking Places (Scotland) Act 2009, Scottish Parliament, 2009

http://www.opsi.gov.uk/legislation/scotland/acts2009/asp_20090003_en_1

BS 5930 Code of Practice for Site Investigation, BSI

<http://www.bsigroup.co.uk/>

BS 10175 Investigation of Potentially Contaminated Sites – Code of Practice, BSI

<http://www.bsigroup.co.uk/>

BS 1377 - 4 Methods of Test for Soils for Civil Engineering Purposes. Compaction-Related Tests, BSI

<http://www.bsigroup.co.uk/>

BS EN 124 Gully Tops and Manhole Tops for Vehicular and Pedestrian Areas, BSI

<http://www.bsigroup.co.uk/>

HA 40/01 Determination of Pipe and Bedding Combinations For Drainage Works, DMRB

<http://www.standardsforhighways.co.uk/dmrb/vol4/section2/ha4001.pdf>

Interim Advice Note 73/06 Design Guidance for Road Pavement Foundations (Draft HD25), DMRB

<http://www.standardsforhighways.co.uk/ians/pdfs/ian73.pdf>

HD 26/06 Pavement Design, DMRB

<http://www.standardsforhighways.co.uk/dmrb/vol7/section2/hd2606.pdf>

TRL 611 A guide to the Use and Specification of Cold Recycled Materials for the Maintenance of Road Pavements, Transport Research Laboratory

<http://www.trl.co.uk/default.htm>

BS EN1338 Concrete Paving Blocks, BSI

<http://www.bsigroup.co.uk/>

BS 7533 Pavements Constructed with Clay, Natural Stone or Concrete Pavers. Code of Practice, BSI

<http://www.bsigroup.co.uk/>

Natural Stone Paving Guide, SCOTS

<http://www.scotsnet.org.uk/>

BS EN 1340 Concrete Kerb Units, BSI

<http://www.bsigroup.co.uk/>

Flood Risk Management (Scotland) Act 2009, Scottish Parliament

http://www.opsi.gov.uk/legislation/scotland/acts2009/pdf/asp_20090006_en.pdf

The Water Environment (Controlled Activities) (Scotland) Regulations 2005, Scottish Parliament, 2005

<http://www.opsi.gov.uk/legislation/scotland/ssi2005/20050348.htm>

Planning Advisory Note 61: Planning and Sustainable Drainage Systems, Former Scottish Executive, 2001

<http://www.scotland.gov.uk/Publications/2001/07/pan61>

Planning Advisory Note 69: Planning and Building Standards Advice on Flooding, Former Scottish Executive,

<http://www.scotland.gov.uk/Publications/2004/08/19805/41595>

The Water Environment and Water Services (Scotland) Act 2003, Scottish Parliament, 2003

http://www.opsi.gov.uk/legislation/scotland/acts2003/asp_20030003_en_1

Coast Protection Act 1949, UK Parliament, 1949

http://www.opsi.gov.uk/RevisedStatutes/Acts/ukpga/1949/cukpga_19490074_en_1

Water Environment (Controlled Activities) (Scotland) Regulations 2005 - A Practical Guide, SEPA,

http://www.sepa.org.uk/water/regulations/application_forms.aspx

Planning Advice Note 45 – Renewable Energy Technologies, Scottish Government, 2005

<http://www.scotland.gov.uk/Publications/2002/02/pan45/pan-45>

<http://www.scotland.gov.uk/Publications/2008/11/12125039/13> (Annexe 2, published 2008)
