

**4m column, 5m column,
5m collapsible column**

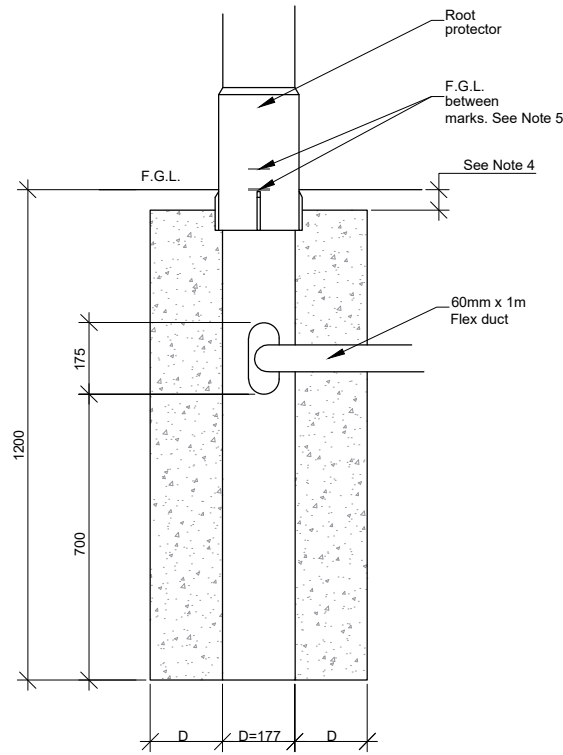

8m column

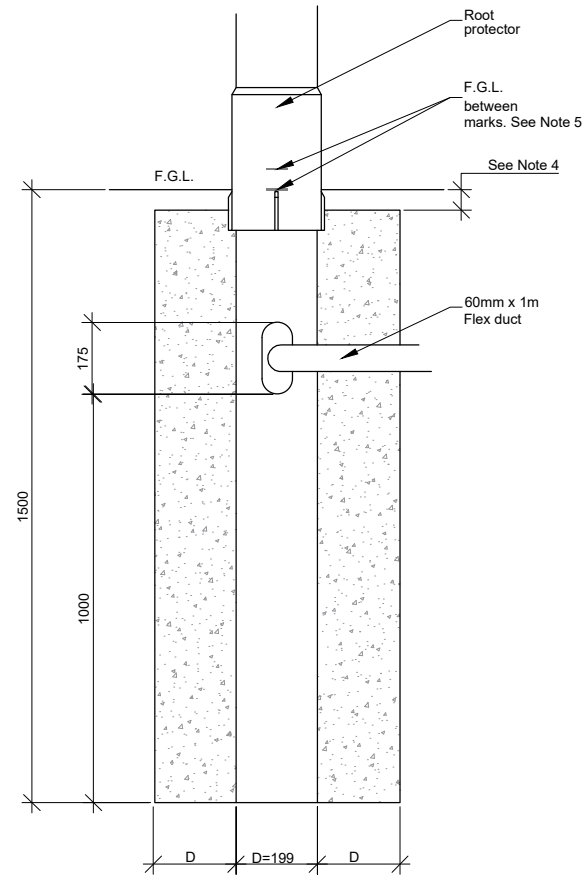

10m column

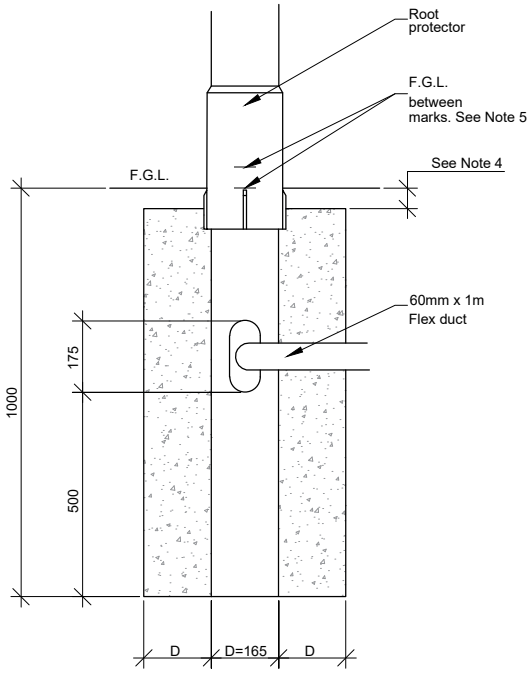

6m column

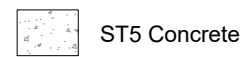

- Notes**
- © Crown Copyright and database rights 2023 AC0000849432
 - 1. All dimensions in millimeters.
 - 2. D = Diameter of Column base.
 - 3. Cables in 60mm duct at entry to column
 - 4. Depth varies dependant on material required as follows:
 - 50mm close graded surface course.
 - 50mm ST5 Concrete
 - 100mm Topsoil Class 5A
 - 5. Distance between markers is usually 50mm. The presence of root protector and F.G.L markers is dependent on manufacturer and column specification.

Revision Details			
Drawn by	Checked by	Check Date	Surf



Project: Standard details. Series 1400:
 Electrical work for road lighting and traffic signs

Title: **Aluminium column foundation**

Scale (at A4): **Not to scale**

Drawn	JC	Date	05/2024
Checked	CHK	Date	06/2024

Drawing No: **SD/1400/04** Rev: **1**