

Notes

- © Crown Copyright and database rights 2023 AC0000849432
- All dimensions are in millimetres unless otherwise stated.
 - This type of steps are to be part only of landscaped areas or informal and unsurfaced remote paths.
 - Rise and tread of steps to should be uniform. Rise 150-170mm, going 280-425mm. The width of the steps shall normally be 900mm. If width of steps is to exceed 900mm the steps will be divided up so that the width between handrails is not more than 900mm. This is to ensure all users have access to handrails.
 - Landings to be provided between flights of steps. Max. rise of individual flight: 1800mm, minimum landing length 900mm, minimum width 900.
 - The specification referred to in this drawing is the Specification for Highway Works (SHW) published by T.S.O. (The Stationary Office).
 - All timber and fittings shall comply to BS 1722 Part 7 and SHW Clauses 304, 305, 306, and 311.
 - Handrail to be provided when total rise of steps exceeds 600mm
 - The handrail and rail to have edges rounded off and made smooth.
 - Length of flight of steps to be determined by width of side slope.

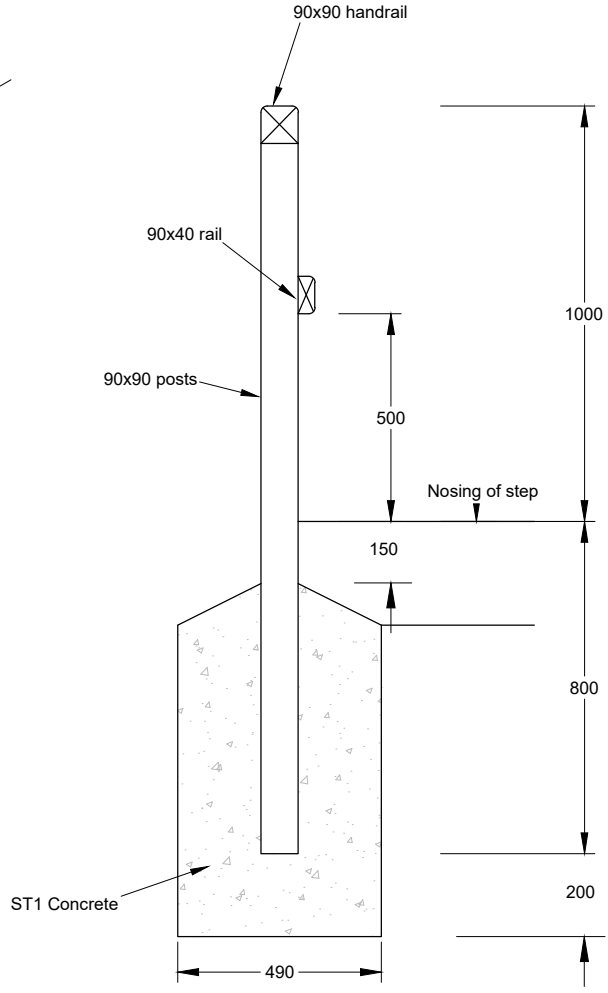

Revision Details				
Drawn by	Checked by	Checked Date	Checked by	Suffix

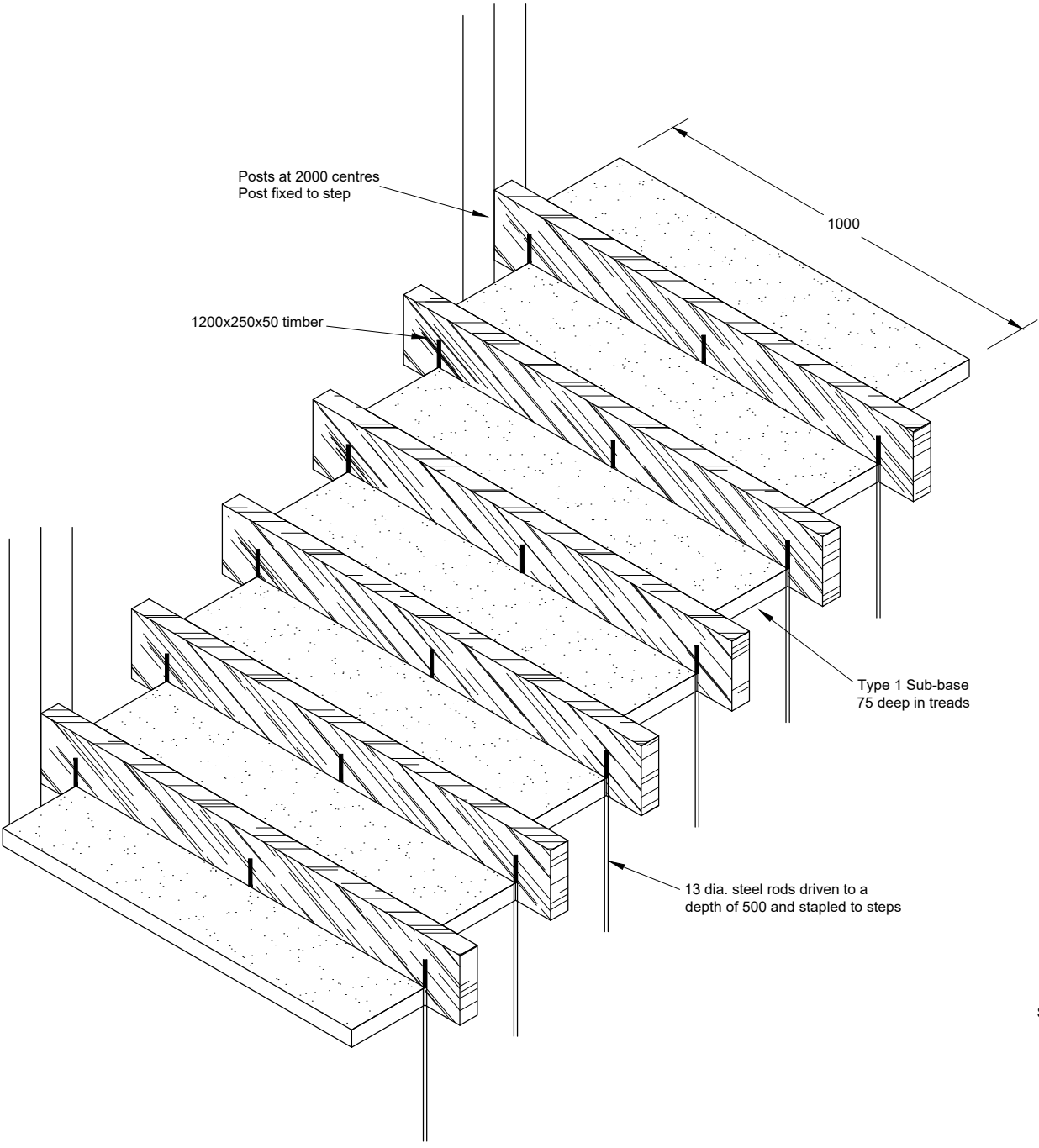

Project	Standard details.			
Title	Series 2600: Miscellaneous Timber steps and handrail on landscaped areas and remote paths			
Scale (at A4)	Not to scale			
Drawn	JC	Date	07/2024	
Checked	CHK	Date	07/2024	
Drawing No.	SD/2600/04			Rev: 1